

Powr-Flite[®]

OPERATOR'S MANUAL

Automatic Scrubber PAS20BA-BC



**WARNING: OPERATOR MUST READ AND UNDERSTAND THIS MANUAL
COMPLETELY BEFORE OPERATING THIS EQUIPMENT.**

©Tacony Corporation, All rights reserved

PAS20BA-BC-MAN 04/2021

Save These Instructions

TABLE OF CONTENTS

Safety Instructions	3
Machine Set-Up.....	4
Machine Specification.....	4
Replacement Parts:.....	8
Brush.....	8
Clutch Plate	8
Battery	8
Charger	8
Daily Operation and Maintenance	5
How to Install Batteries.....	5
How to Charge the Batteries	5
How to Install the Squeegee.....	5
How to Install Pad Holder and Brush.....	5
How to Fill the Solution Tank	5
How To Operate The Machine	6
How to Turn the Vacuum Motor On and Off.....	6
How to Lower/Raise the Brush/Pad.....	6
How to Lower/Raise the Squeegee.....	6
How to Set the Solution Flow	6
What to Do When You're Operating The Machine	7
Vacuuming Up Solution.....	7
How to Control Excess Foam in the Recovery Tank	7
How to Empty the Recovery Tank	7
Maintenance	7
Daily	7
Weekly	7
Monthly.....	7
Troubleshooting.....	8
Warranty.....	9

SAFETY INSTRUCTIONS
FOR COMMERCIAL USE
READ ALL INSTRUCTIONS BEFORE USING THIS MACHINE

- Use indoors only. Do not expose to rain.
- Do not allow it to be used as a toy. Use caution when operating near children.
- Use only as described in this manual.
- Use only manufacturer’s recommended accessories.
- Charge batteries in a ventilated room. Gases given off during charging could ignite in a confined space. To avoid an explosion, top cover should be open and battery caps installed when charging.
- Disconnect all positive and negative battery terminals before attempting any adjustment or maintenance. Brush drive and vacuum motors and components can cause injury if accidentally started.
- Battery acid can cause injury to the eyes or skin. Wear protective goggles, gloves and clothing BEFORE filling or charging batteries.
- If charger is not working properly, (due to it being dropped, damaged, left outdoors or exposed to water) return it to a Powr-Flite Service Center.
- Do not handle the plug or machine with wet hands.
- Do not put any objects into openings. Keep the openings unblocked
- Keep it away from dust, lint, hair and anything that may reduce air flow.
- Keep hair, loose clothing, fingers and all body parts away from openings and moving parts.
- Make sure the main power switch is OFF before removing or installing pads or brushes.
- Never operate the machine if you are tired or under the influence of drugs and/or alcohol.
- Always operate the machine while standing behind it.
- Use care when working on electrical terminals. Short circuits can cause burns.
- Do not store the machine on inclines.
- If it is suspected that there is hazardous dust or flammable materials stop cleaning the area immediately and consult your supervisor.
- Only use accessories and spare parts provided with the machine or those approved by the manufacturer. The use of other accessories may impair the safety of the machine and void the warranty.

Machine Specification

PAS20BA-BC Automatic Scrubber	
Brush Width	20"
Squeegee Width	30"
Solution Tank	11 gal.
Recovery Tank	12 gal.
Brush Rotation	200 rpm
Productivity Rate	17,500 ft ² per hour
Voltage	24 V
Vacuum Motor Power	.75 HP/23A
Brush Motor Power	.75 HP/23A
Weight (without Batteries)	210 lbs.
Length x Width x Height	49" x 26" x 44"

Machine Set-Up

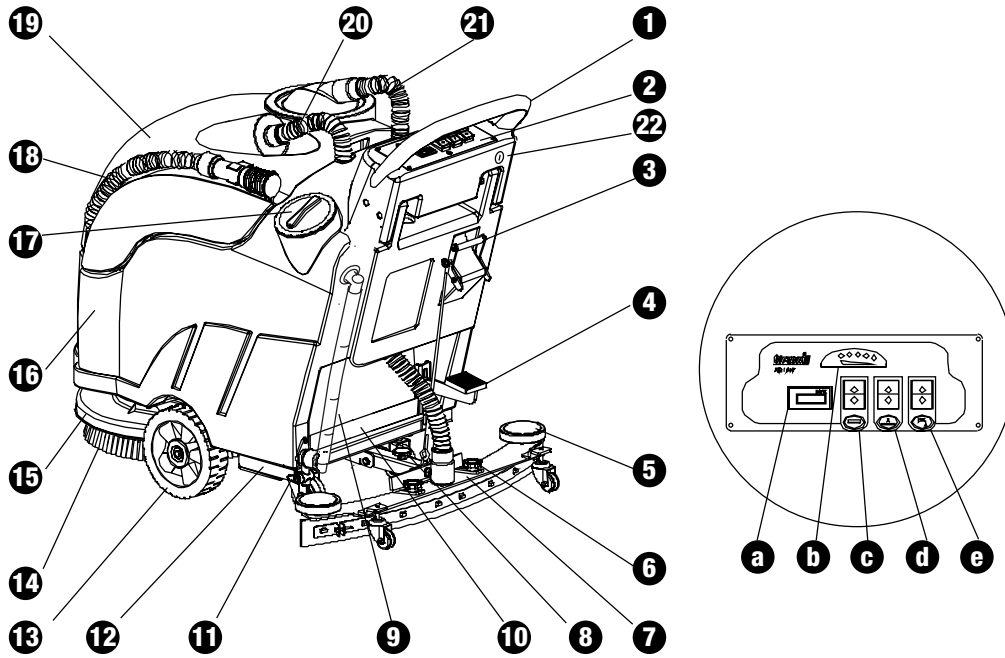

- | | |
|--|---|
| <ul style="list-style-type: none"> 1. Handle Bar 2. Control Panel <ul style="list-style-type: none"> a ... Hour Meter b ... Battery Condition Indicator c ... Brush Motor Switch d ... Vacuum Motor Switch e ... Solution Switch 3. Squeegee Release Handle 4. Brush Lift Pedal 5. Wheel, Bump 6. Squeegee Mount Knob 7. Squeegee 8. Squeegee Tilt Knob 9. Water level sight tube | <ul style="list-style-type: none"> 10. Battery 11. Valve, Solution Volume Control 12. Frame 13. Wheel 14. Brush/Pad Holder 15. Strap, Splash Guard 16. Solution Tank 17. Solution Fill Hole 18. Recovery Drain Hose 19. Recovery Tank 20. Squeegee Hose 21. Vacuum Hose 22. Key Switch |
|--|---|

Replacement Parts

PART	DESCRIPTION
Brush	
SF219	Poly Scrub Brush (Optional)
PFLG19	Lite Grit Scrub Brush (Optional)
PFMG19	Medium Grit Scrub Brush (Optional)
PFHG16	Heavy Grit Scrub Brush (Optional)
Clutch Plate	
UP2P	Clutch Plate (must be used with all scrub brushes)
Pad Holder	
PAS20PD	20" Pad Driver
Battery	
B27TMX	12 Volt Battery (2 Required)
Charger	
99628	24 Volt, 25 Amp Charger

How to Install Batteries



Caution: Batteries are heavy.

Install (2) 12-volt deep cycle batteries. New Batteries should be given a full charge before first use.

1. Unplug the hoses (20, 21) from the recovery tank (19).
2. Make sure the recovery tank is empty then lift it up.
3. Place batteries on the tray. Use the bracket to secure them. Position them correctly.
4. Connect all the cable terminals.



Caution: Make sure you connect RED (+) cable terminals to positive (+) posts and BLACK (-) cable terminals to negative (-) posts. Machine will not operate if not connected properly. Failure to do so will result in damage to batteries and possible explosion.

Spray each post with a protective lubricant. Place battery terminal protectors over all posts.

How to Charge the Batteries



Caution: Only use a battery charger designed for the machine. Failure to do so can result in damage to the batteries.

Remove the recovery tank from machine and disconnect anderson plug from the control panel. Next connect the charging plug to the anderson plug connected to the battery terminal. Plug the other charger plug to wall outlet. The charger will automatically begin to charge the batteries.

How to Install the Squeegee

1. Put squeegee Release Handle (3) in the UP and locked position.
2. Position the squeegee blade assembly on the swing arm. Make sure the guide wheels face the rear of the squeegee.
3. Hand tighten the 2 thumb screw (6).
4. Place the solution recovery hose (20) over the nozzle. Make sure it fits tight.

How to Install Pad Holder and Brush

1. Raise the brush pad by stepping on Brush Lift Pedal (4) at the rear of the machine.
2. With the pad holder/brush (14) in lifted position, insert it into the plate underneath by turning it counter-clockwise until it locks.

How to Fill the Solution Tank

1. Open the solution fill cover (17).
2. Fill the tank (16) with the desired level of clean water.
3. Add cleaning chemical.



Do not overfill.

How To Operate The Machine

1. To turn the power on, turn the key switch (22). The power/battery indicator (b) will light up.
2. Check the battery capacity to see if it is full – all indicators are lit up when batteries are fully charged.
3. To turn on the brush motor, vacuum motor and the solution flow, press the switches (c,d,e).



Turn off the brush motor when the brush deck is in the up position.

How to Turn the Vacuum Motor On and Off

1. Push the top half of the right switch (d) down. This turns the vacuum motor on.
2. To turn the vacuum motor off, push the lower half of the right switch (d) down.

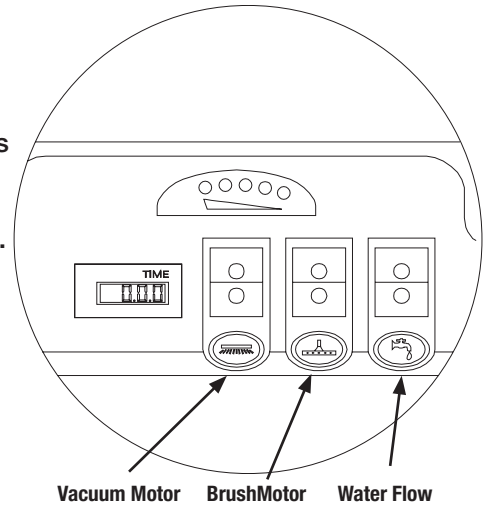

How to Lower/Raise the Brush/Pad

1. To raise the brush pad, step down on the Brush Lift Pedal (4) until it locks in place.
2. To lower the brush pad, slightly step on the Brush Lift Pedal (4) to unlock it, and raise it up slowly.

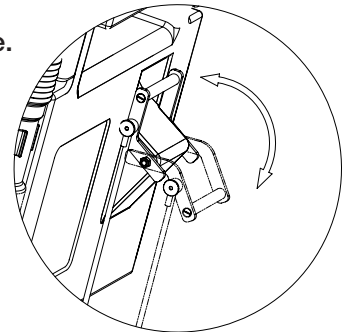

How to Lower/Raise the Squeegee

1. Pull the handle (3) down to lower the squeegee.
2. Lift the handle (3) up to raise the squeegee.

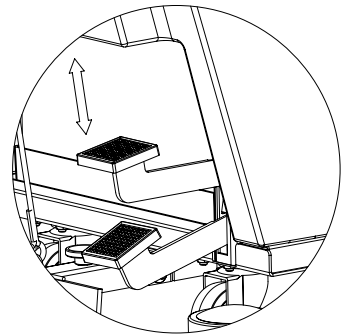

How to Set the Solution Flow

Adjust the water flow based on the floor conditions. Turn the adjustment knob (11) to control the water flow. Position 1 shows the closed position. Position 2 shows the maximum water flow position.

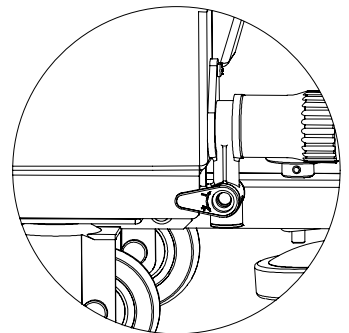
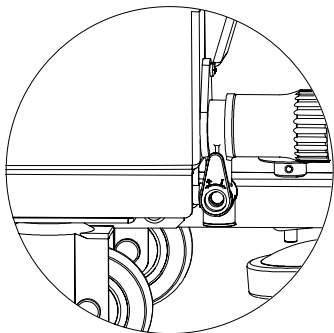

What to Do When Operating The Machine

Vacuuming Up Solution

1. Make sure the squeegee is in the down position.
2. As the machine moves forward and solution is dispensed, the squeegee will vacuum it up into the recovery tank.
3. If necessary adjust squeegee pressure by turning knob (8).

If solution is missed, reduce the amount of solution flow, raise the squeegee and pull the machine back over the missed area. Lower the squeegee and move the machine forward to pick up any remaining solution.

How to Control Excess Foam in the Recovery Tank

Watch the liquid as it accumulates in the recovery tank. If you notice excess foaming, stop the machine. Add the recommended amount of chemical defoamer in the recovery tank (19).

How to Empty the Recovery Tank

Open the Recovery Drain Hose (18) to empty the Recovery Tank (19).

Maintenance

Daily

1. Empty and rinse the recovery tank with clean water. Leave the tank cover (21) open on top to air dry.
2. Remove the squeegee assembly, rinse and wipe clean. Check the squeegee inlet for clogs or debris.
3. Clean and wipe the tops of batteries with an ammoniated window cleaner.
4. Fill each battery cell with DISTILLED water as needed. DO NOT use tap water.
5. Charge the batteries as described in this manual.

Weekly

 Never test the strength of the battery unless it is fully charged and cool. Check the battery cells with a hydrometer.

Monthly

1. Lubricate brush and squeegee lift mechanisms with light oil.
2. Check for wear or damage of clutch plate, brushes, pads or squeegee blades.
3. Clean all battery terminals.
4. Check all electrical connections and tighten if any are loose.
5. Clean the entire machine with all purpose cleaner.

Troubleshooting

WARNING - Before performing maintenance or making adjustments, switch off the machine and disconnect the battery.

Problem:	Possible Cause:
Solution is not being picked up	Vacuum motor is not running Water filter is clogged Recovery tank is full Squeegee or vacuum hose is clogged, broken or disconnected Bad seal at tank cover, vacuum motor or squeegee Worn or misaligned squeegee blades. Incorrect squeegee pressure. Squeegee swing arm mechanism not functioning properly
Squeegee is leaving streaks	Debris is on blade Blades are torn or damaged Floors not properly swept before cleaning
Solution is not feeding or turning off properly	Clogging of hose or valve
Batteries are not holding a charge	Batteries need to be replaced High current draw from high brush pressure Charger needs servicing Battery is run down
Floors are not being scrubbed, stripped or buffed properly	Brush motor not working Excessive pad or brush wear Going too fast over dirty spots Inadequate solution feed Inadequate cleaning procedure

* If the fuse blows several times, the machine should be checked by an authorised Service Agent

For warranty information go to www.Powr-Flite.com

Powr-Flite[®]

A Tacony Company

3101 Wichita Court • Fort Worth, TX 76140-1755
1-800-880-2913 • Fax: 1-817-551-0719 • www.Powr-Flite.com