

AIRMAN

PG

INSTRUCTION MANUAL

SCREW COMPRESSOR

PDS185S-6C2

Please be sure to read this manual
before using this machine.

HOKUETSU INDUSTRIES CO., LTD.

Preface

Thank you for having selected our “AIRMAN” product.

- ◆ This manual explains about the proper operation and daily inspection and maintenance of this machine.
- ◆ In order to use a machine safely, people with sufficient knowledge and sufficient technology need to deal with it.
- ◆ Before operating the unit, read the manual carefully, fully understand its operation and maintenance requirement. Maintain “SAFETY OPERATION AND PROPER MAINTENANCE OF THE UNIT”.

Be sure to follow safety warnings and cautions given in the manual.
Unsafe operation could cause serious injury or death.

- ◆ For details of handling, maintenance and safety of the engine, see the Engine Operation Manual.
- ◆ Keep the manual available at all times for the operator or safety supervisor.
- ◆ If the manual is lost or damaged, place an order with your dealer for another copy.
- ◆ Be sure that the manual is included with the unit when it is handed over to another user.
- ◆ There may be some inconsistency in detail between the manual and the actual machine due to improvements of the machine. Ask your dealer if you have any questions or problems.
- ◆ If you have any questions about the unit, please inform us the model and serial number. A plate stamped with the model and serial number is attached to side of the unit.

PORTABLE COMPRESSOR	
MODEL	<input type="text"/>
SER. NO.	<input type="text"/>
NORMAL OPERATING PRESSURE	<input type="text"/> MPa
NET DRY MASS	<input type="text"/> kg
AIRMAN MADE IN JAPAN HOKUETSU INDUSTRIES CO., LTD. 22-2, NISHI-SHINJUKU 1-CHOME, SHINJUKU-KU TOKYO JAPAN	

A990054

- ◆ Each illustrated figure (Fig.) has a number (for instance, A990054) at the right bottom. This number is not a part number, but it is used only for our reference number.



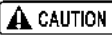

Table of Contents

1. Safety	1-1
1.1 Caution before Operation	1-2
1.2 Caution during Operation	1-5
1.3 Caution during Inspection and Maintenance	1-7
1.4 Safety Warning Labels	1-10
2. Part Names	2-1
2.1 Internal Components and Part Names	2-1
3. Installation	3-1
3.1 Transportation	3-1
3.2 Towing the Unit	3-2
3.3 Installation	3-3
4. Operation	4-1
4.1 Instrument Panel	4-1
4.2 Lubricating oil • Coolant • Fuel	4-2
4.3 Check before Starting Unit	4-4
4.4 Operation	4-8
4.5 Capacity Control Device	4-12
4.6 Stopping	4-14
4.7 Air bleeding in fuel line	4-14
5. Periodic Inspection/Maintenance	5-1
5.1 Important Items as Periodic Inspection and Maintenance or after Maintenance	5-1
5.2 Daily Inspection and Operation Log	5-2
5.3 Periodic Inspection List	5-3
5.4 Periodic Replacement of Parts	5-5
5.5 Maintenance Items	5-6
6. Maintenance	6-1
6.1 Maintenance of Battery	6-1
6.2 Indicator lamp and Warning / Emergency display	6-3
6.3 Troubleshooting	6-4
6.4 Adjustment of various data	6-5
7. Storage of the Unit	7-1
7.1 Preparation for Long-term Storage	7-1
8. Specifications	8-1
8.1 Specifications	8-1
8.2 Outline drawing	8-2
9. Wiring Diagram	9-1
10. Piping Diagram	10-1
10.1 Air piping • Compressor oil piping	10-1
10.2 Fuel piping	10-2

1.Safety

This manual explains and illustrates general requirements for safety.

Read all safety requirements carefully and fully understand the contents before starting the machine.

For your better recognition, according to the degree of potential danger, safety messages are classified into three hierarchical categories, namely, , , and  with a caution symbol  – attached to each message.

When one of these messages is shown, please take preventive measures and carry out “SAFETY OPERATION AND PROPER MAINTENANCE OF THE UNIT”.



DANGER indicates an imminently hazardous situation which, if not avoided, will result in death or serious injury. This signal word is to be limited to the most extreme situations.



WARNING indicates a potentially hazardous situation which, if not avoided, could result in death or serious injury.



CAUTION indicates a potentially hazardous situation which, if not avoided, may result in minor or moderate injury. It may also be used to alert against unsafe practices.



IMPORTANT indicates important caution messages for the performance or durability of the unit.

Follow warnings mentioned in this manual. This manual does not describe all safety items. We, therefore, advise you to pay special attention to all items (even though they may not be described in the manual) for your safety.

1.Safety

1.1 Caution before Operation



Compressed air is prohibited to be used for human respiration

- Compressed air by this unit contains poisonous materials. Absorption of the compressed air can cause serious injury. Never provide this compressed air for human respiration.
- This unit is not designed to be used for working chambers pressurized by compressed air such as respiratory air provided to persons working inside wells and tunnels such as pneumatic engineering method and pneumatic caisson method. Should this unit stop operation due to trouble, it can cause death and serious injury to the working persons. Refrain from using the compressed air for such pneumatic engineering method or pneumatic caisson method.

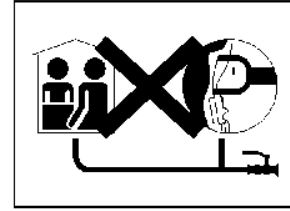

TR0201-1

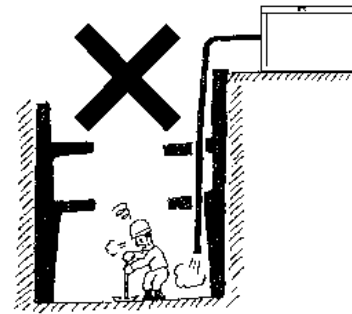

A080001



Follow the safety instructions

- Read each instruction plate which is displayed in the manual or on the unit carefully, understand its content and follow the indications thereof.
- Keep the Safety Warning labels clean. When they are damaged or missing, apply new ones.
- Do not modify the machine without prior approval. The safety may be compromised, functions may be deteriorated, or machine life may be shortened.
- Never use the unit for the purpose of compression of gases other than air, or as a vacuum pump. Otherwise, serious accidents may occur.

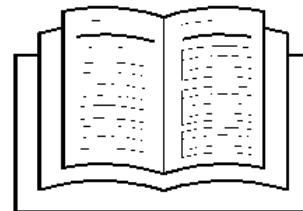

TR0086



Ventilation

- Exhaust gas from the engine is poisonous, and could cause death when inhaled. Avoid using the machine in an insufficiently ventilated building or tunnel.

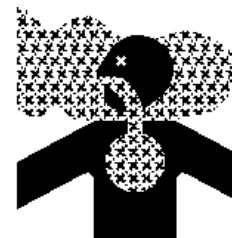

PC002

1.Safety

WARNING

- Keep flames away from battery.
- Battery may generate hydrogen gas and may explode.
- Battery electrolyte is dilute sulfuric acid.
In case of mishandling, it could cause skin burning.
- When you deal with a battery, please be sure to wear protection implements, such as protection glasses and a glove.
- Dispose of battery, observing local regulations.

Handling battery

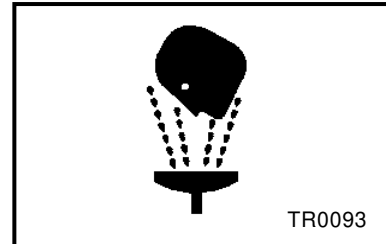

WARNING

Cautions of hose attachment and removal

- Piping or the hose from this machine service valve should use what can be borne enough for the discharge pressure of this machine.
- Please connect piping or a hose to this machine service valve firmly before operation and during operation. If the connection part is loosening, there is a possibility of piping or a hose separating and getting seriously injured.
- Please remove after closing a service valve and extracting pressure remained, in case piping or a hose is removed. If pressure remained should remain, a near thing blows away or there is a possibility of a hose whipping, causing a phenomenon and getting seriously injured.
- In order to use it safely, please read the handling of the work tools often used.

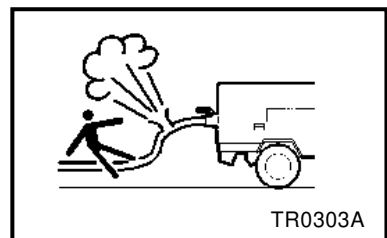
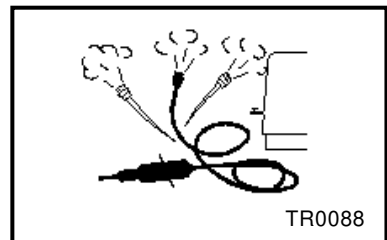

WARNING

Safety outfit

- When handling machine, do not wear;
 - Loose clothes
 - Clothes with unbuttoned sleeves
 - Hanging tie or scarf
 - Accessories such as dangling jewelry
- Such outfit could be caught in the machine or dragged in the rotating portion of the machine, and this could cause a serious injury.

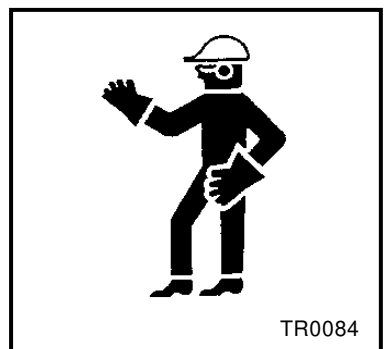

1.Safety

WARNING

Maintain both physical and mental health

- Do not operate the machine when you are tired or drunk or under the influence of drugs. Otherwise, a hasty conclusion or careless handling may cause unexpected injury or accident.
Manage your physical and mental health and be cautious in handling the machine.

CAUTION

- Please wear protection implements, such as a helmet, protection glasses, earplugs, safety shoes, a glove, and a protection-against-dust mask, according to the contents of work for safety.

Protection equipments

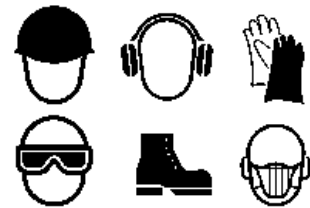

TR0085

CAUTION

- Have first-aid boxes and fire extinguishers near the unit ready for emergency situations such as injuries and a fire.
- It is advisable to have a list of phone numbers of doctors, ambulance and the fire department available in case of emergency.

Safety fittings



TR0096

CAUTION

Safety around the machine

- Such things as unnecessary equipment and tools, cables, hoods, covers and pieces of wood which are a hindrance to the job, have to be cleaned and removed. This is because operators and/or personnel nearby may stumble on them and may be injured.
- Place safety enclosures at the entrance of and around working site to prevent children or outside people from entering the site.

1.Safety

1.2 Caution during Operation

WARNING

Do not replenish compressor oil during operation

- Do not, under any circumstance, open the oil filler cap of separator receiver tank while running or immediately after stopping operation.
It is very dangerous because the oil filler cap could be blown off and high temperature compressed air and oil could jet out from the filler port, and cause serious injury.

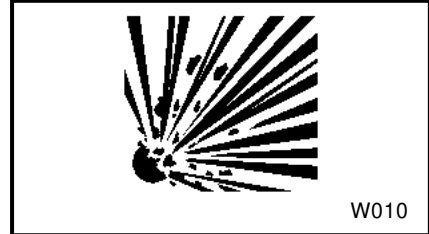

WARNING

Draining during operation prohibited

- Do not, under any circumstance, open the portions below during operation:
- Separator receiver tank drain valve
- Coolant drain valve and plug
- Engine oil drain valve
- Oil cooler drain valve
- Fuel tank drain valve and plug

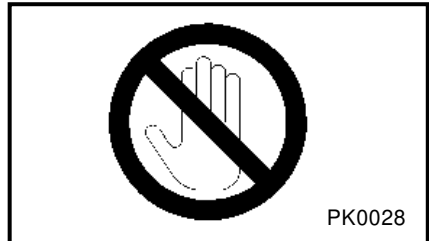

WARNING

Never direct the compressed air to people and foods

- Never blow compressed air directly at people.
Scattered impurities, dust, or foreign objects in the compressed air may cause skin and eyes to be seriously injured.
- Blowing compressed air on food is prohibited.

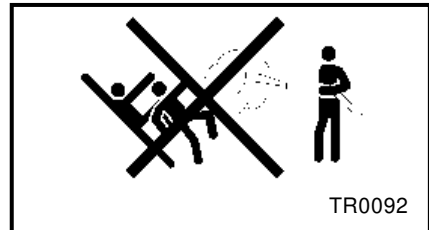

WARNING

Hands off from rotating parts and belts

- Keep hands off from the rotating portion or belts while running.
It could cause serious injuries if hands should be caught in.



CAUTION

Do not remove radiator cap during operation

- Do not, under any circumstance, open the radiator cap while running or immediately after stopping operation. Otherwise high temperature steam jets out and this could cause scalding.

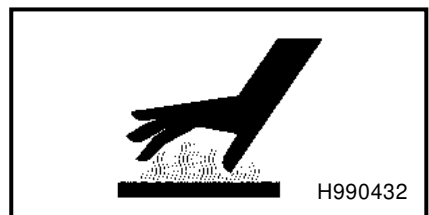

1.Safety

CAUTION

Operation with compressed air supply port opened is prohibited

- Do not operate the machine with service valves and relief valve open unless air hoses and/or pipes are connected. High-pressurized air blows out and its air pressure could cause injury to the people nearby.
- When the machine has to be unavoidably temporarily operated with its port open, be sure to mount a silencer to reduce noise and wear protective materials such as earplugs to prevent damage to hearing.

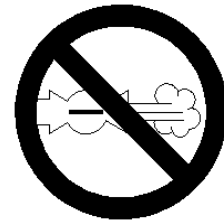

D003

CAUTION

Do not touch hot parts

- Never work nearby hot portions of the machine while it is running.
- Do not touch hot portions of the machine while inspecting the machine when running.
- Such parts as engine, exhaust manifold, exhaust pipe, muffler, radiator, oil cooler, compressor, piping, separator receiver tank, and discharging pipe are especially hot, so never touch those parts, because it could cause serious burns.
- Compressor oil, coolant water, and engine oil are also very hot and dangerous to touch. Avoid checking or refilling them while the unit is running.



H990432

CAUTION

Fire prevention

- Do not, under any circumstance, bring lit cigarettes or matches near such oils as engine oil and compressor oil, etc. They are extremely flammable and dangerous, so be careful when handling.
- Refilling oils should be done in an outdoor well-ventilated place.
- Refuel after stopping the engine, and never leave the fuel nearby the machine. Do not spill. It may cause a fire. When it is spilt, wipe it up completely.
- **Do not fill fuel oil up to the cap lever. When fuel tank is filled up to the cap level, fuel oil will be overfilled due to volume expansion caused by rise of ambient temperature. Further, fuel will be possibly spilled from fuel tank due to vibration caused during movement and/or transportation of machine.**
- Such parts as muffler and exhaust pipe can be extremely hot. Remove twigs, dried leaves, dried grass and waste paper, etc. from the exhaust outlet of the muffler.
- Keep a fire extinguisher available by the machine in case of a fire.



D004



H990433

1.Safety

1.3 Caution during Inspection and Maintenance



Hang a “Now Checking and under Maintenance” tag

- Remove the starter key from the starter switch before starting inspection, and hang up a “Now Checking and under Maintenance” tag where it can be easily seen. The checker must keep the key during checking and maintenance.
- Remove the negative (-) side cable from the battery. If the above procedure is neglected, and another person starts operating the machine during check or maintenance, it could cause serious injury.

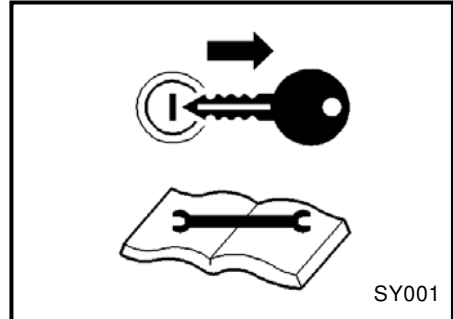

Refilling of compressor oil

- When you refill the separator receiver tank with compressor oil, stop the engine, and make sure that the pressure gauge indicates 0psi(0bar) and there is no residual pressure in it, and then gradually loosen the oil filler cap for refilling oil.
- Note residual pressure in the separator receiver tank could force both extremely hot compressed air and oil to jet out and you may be scalded or seriously injured.

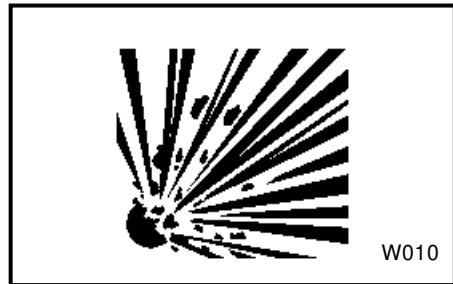

Be careful of high-pressurized air blowout

- After stopping the engine, make sure that pressure gauge indicates 0MPa. Even when the gauge shows 0psi(0bar), open a service valve and further do not fail to make sure that there is no residual pressure in the air piping. Then start such a job as repair and maintenance.
- Residual air under pressure will blow off and severely injure operator.

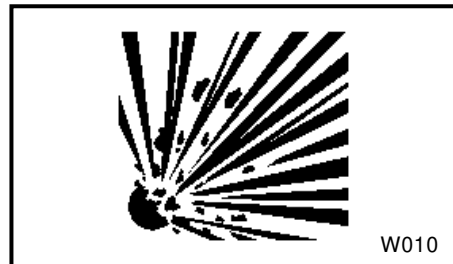

Draining separator receiver tank

- After stopping the engine, confirm that the pressure gauge indicates 0psi(0bar) and there is no residual pressure in it, then open the drain valve gradually to drain the compressor oil.
- Note residual pressure in the separator receiver tank could force both extremely hot compressed air and oil to jet out and you may be scalded or seriously injured.

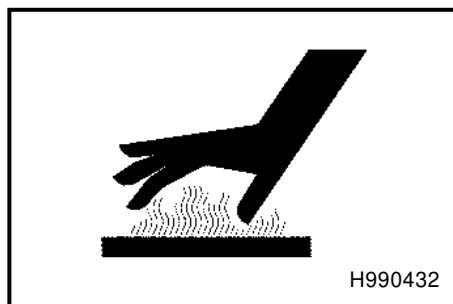

1.Safety

WARNING

- Be sure to stop the engine and remove the starter key whenever the tension of the fan belt is to be adjusted.
- Remove the negative (-) side cable from the battery.
- If the machine is running, it might catch the operator's hand into the fan belts, and this could cause a serious injury.

Adjusting tension of fan belt

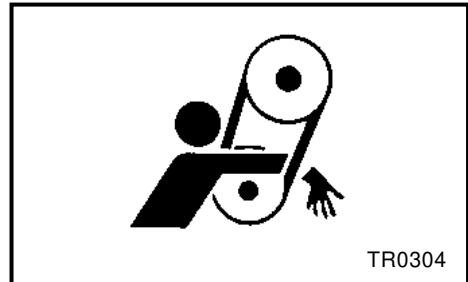

WARNING

- Be sure to stop the engine and remove the starter key whenever check or maintenance work is carried out near the cooling fan.
- If the cooling fan is rotating, it may catch the operator or part of his body into the fan, and it could cause a serious injury.

Hands off from cooling fan

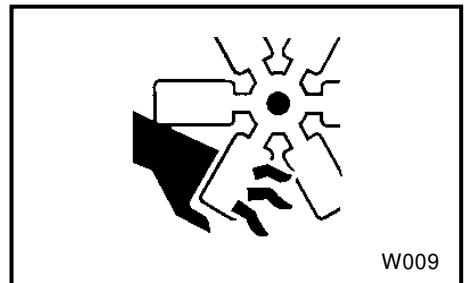

WARNING

- When cleaning dust accumulated in such devices as the air-filter, by blowing compressed air, wear safety glasses, etc. to protect your eyes.

Cleaning by air-blow



CAUTION

- It is recommended to use a lamp with safety guard fitted where the site is dark.
Operating the machine gropingly or by relying on one's intuition could cause unexpected accidents.
- Any lamps without safety guard are not recommended since they can be broken and they could ignite flammables such as fuel, etc.

Lighting apparatus

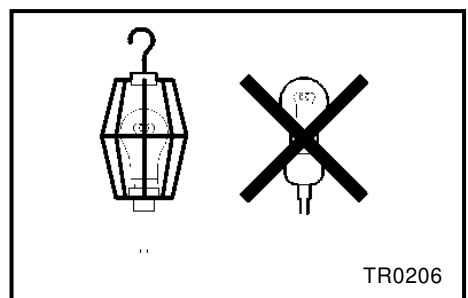

1.Safety

CAUTION

Opening coolant water drain valve cap

- Be sure to stop the engine, and let the coolant water sufficiently cool down before draining it.
- If the drain valve is opened before the coolant water is cooled enough, hot water could jet out, and it could cause scalding.

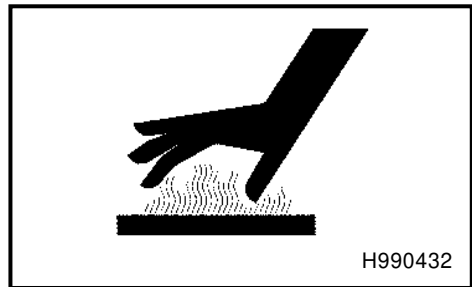

CAUTION

Refilling or draining of engine oil

- After stopping the engine, wait for 10 to 20 minutes until the engine oil cools off. Then check the level of the engine oil, or refill or drain the oil.
- Engine oil is very hot and highly pressurized during or just after the operation. Hot oil could blow out of the tank and can cause scalding.

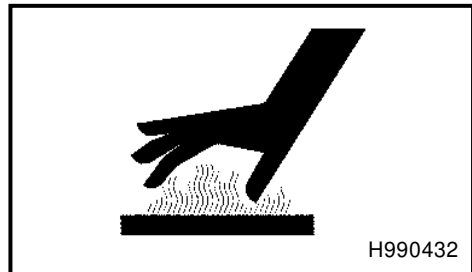

CAUTION

Fear of fire

- Be sure to perform the periodical check of compressor oil and oil separator.
- Neglecting checks could cause overheat of the oil, resulting in a fire.



CAUTION

Treatment of organic wastes

- Waste liquid from the machine contains harmful material. Do not discharge it onto the ground or into the river, lake or sea. Such material will contaminate the environment.
- Be sure to use a container to hold the waste liquid from the machine.
- Be sure to follow the designated regulations when disposing of oil, fuel, coolant (antifreeze), filter, battery or other harmful materials.

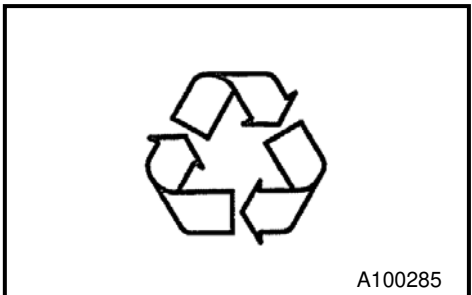





1.Safety





1.4 Safety Warning Labels

Following labels are attached to the machine.

Keep them clean at all times. If they are damaged or missing, immediately place an order with your nearest dealer for replacement. Part numbers are indicated on the lower right corner of the label.

Adhere a new one to the original location.

1	2	3	4	5
▲ DANGER	▲ WARNING	▲ WARNING	▲ CAUTION	▲ CAUTION
				
DO NOT BREATHE COMPRESSED AIR Do not use this compressed air for breathing air because it can cause fatal accidents. Never breathe it. 39176 7360C	BEWARE OF EXHAUST GASES When you operate machine INDOORS or in TUNNEL, provide good ventilation. Poor ventilation can cause fatal accident. 39176 7330D	BEWARE OF RESIDUAL PRESSURE Release residual pressure inside pipings and hoses and then disconnect them. Disconnection with residual pressure still left can cause serious injury. 39176 7340D	PREVENT BURNING ACCIDENT Do not open radiator cap while it is still hot. 39176 6960D	PREVENT BURNING ACCIDENT When work is required near hot parts, wait for the parts to cool down fully before starting work. 39176 6950D

6	7	8	9	10
▲ WARNING	▲ CAUTION	▲ WARNING	▲ WARNING	
				LIFTING BAIL 39176 6930D
BEWARE OF HIGH PRESSURE AIR BLOW OUT Oil supply and/or maintenance jobs with residual pressure left in tank are very dangerous. So release the residual pressure first. 39176 6980D	PREVENT FIRE ACCIDENT Periodically check compressor oil and oil separator surely. Failure of this fire accident. 39176 6970D	BEWARE OF ENTANGLEMENT Keep your hands AWAY from fan during operation. Entanglement in the fan can cause serious injury. 39176 7350D	BEWARE OF ENTANGLEMENT Keep your hands AWAY from moving parts such as V-belts, pulleys etc.. Entanglement in them can cause serious injury. 39176 7380D	

11	
	D DIESEL FUEL
FLAMMABLES	EPA REGULATION
	LOW SULFUR OR ULTRA LOW SULFUR DIESEL FUEL ONLY. DIESEL A FAIBLE TENEUR EN SOUFRE OU DIESEL A TRES FAIBLE TENEUR EN SOUFRE UNIQUEMENT. 39178 2203D

12		
▲ DANGER	▲ WARNING	▲ WARNING
		
ATTENTION TO EXPLOSION If there is damage, dent and rust on the housing, it is in danger of explosion. Must be changed the new one.	ATTENTION TO BLOWOUT During operation or pressure is left at compressor, it is dangerous to remove the housing because of blowout of gas. Compressor must be halted and cut off the power supply. Then remove the housing after making sure the pressure gauge is 0Pa.	ATTENTION TO MAINTENANCE Maintain Oil Separator according to the instruction manual. Separator element and housing should be changed at the same time. Attention to heated surface of the housing during operation.
		39176 7440D

1.Safety

- The pasting position of safe warning label is as follows.

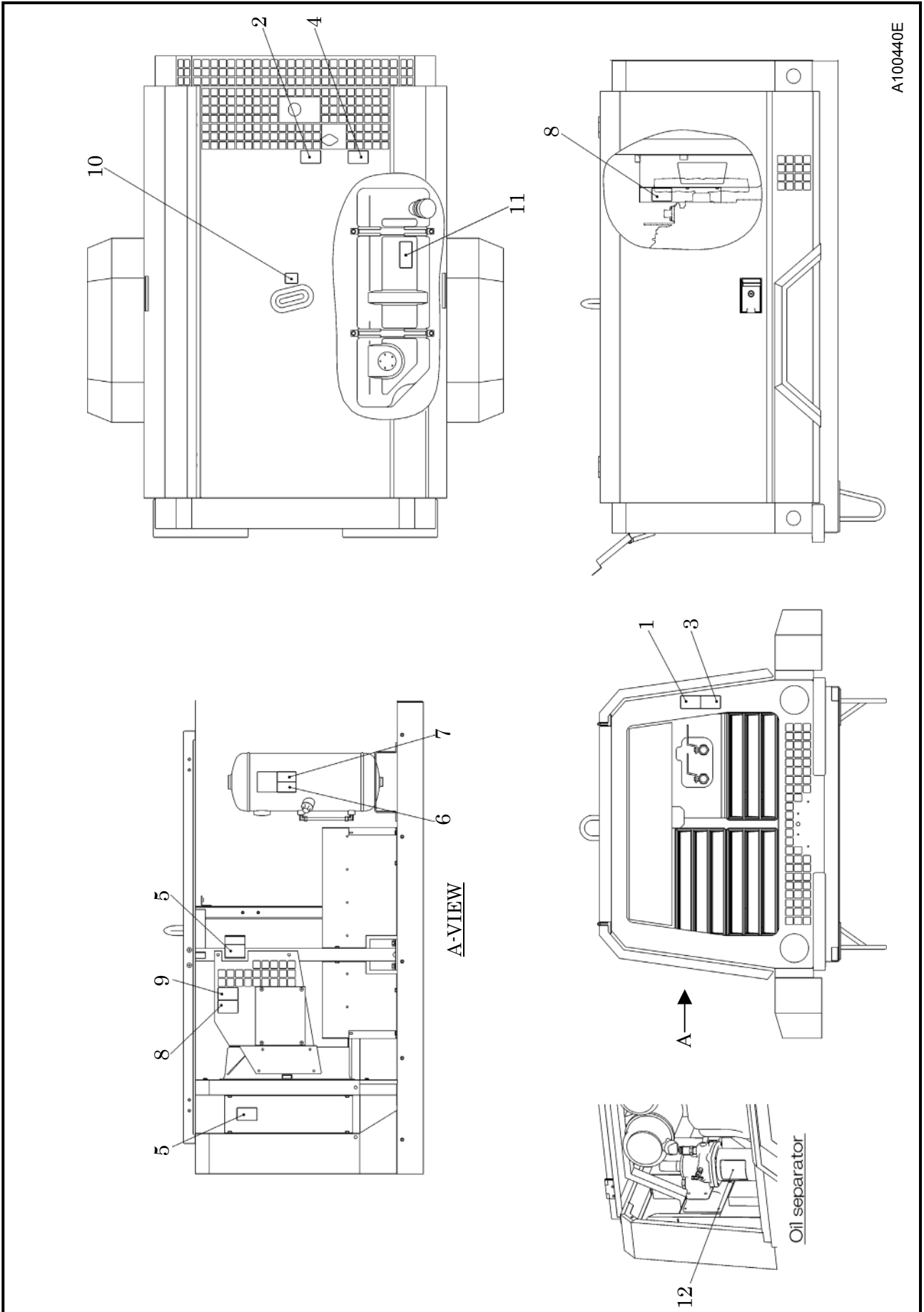

A100440E

2.Part Names

2.1 Internal Components and Part Names

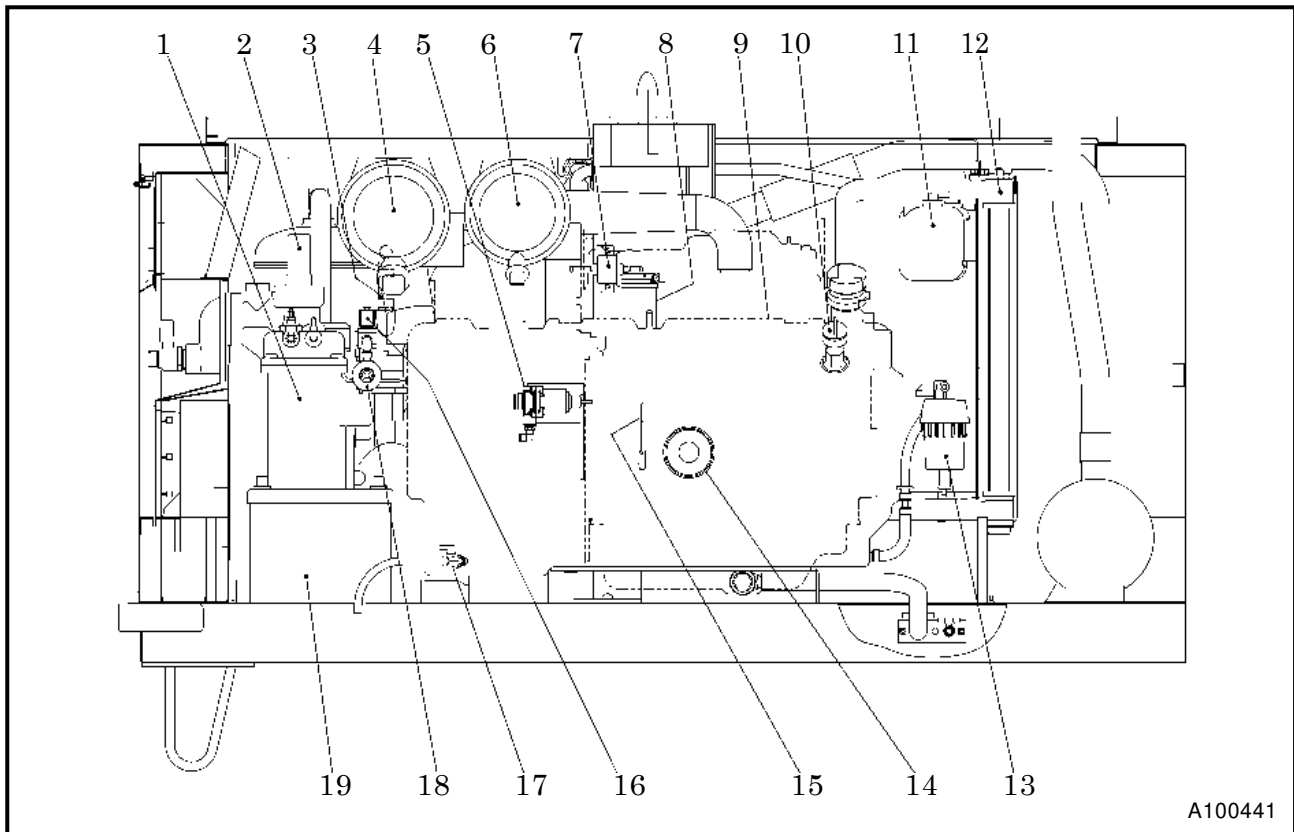

A100441

No.	Description	Function
1	Oil separator	For separating oil mist mixed in compressed air.
2	Pressure control	For keeping the separator receiver tank pressure higher than 58psi (4bar) in the tank.
3	Safety valve	For releasing compressed air to the atmosphere when the pressure rises higher than the rated pressure.
4	Air filter (For Compressor air-end)	For filtering the dust floating in the intake air.
5	Speed regulator	For regulating air-end revolution speed.
6	Air filter (For engine)	For filtering the dust floating in the intake air.
7	Air bleeding electro-magnetic pump	For automatically bleeding air from fuel pipes.
8	Fuel filter	For filtering dust and foreign matter mixed or to be mixed in the fuel oil.
9	Fuel tank	For storing diesel fuel oil.
10	Engine oil filler port	For supplying and replenishing engine oil to engine.
11	Reserve tank	For checking engine cooling water level and for replenishing cooling water.
12	Radiator	For cooling the coolant for engine because it is water-cooled.
13	Sedimenter	For separating water mixed or to be mixed in the fuel oil.
14	Engine oil filter	For filtering engine oil.
15	Engine oil level gauge	For checking engine oil level.
16	Solenoid valve for starting unloader	Control device for reduction of power under unloaded operation.
17	Fuel tank drain valve	For draining condensate accumulated in fuel tank.
18	Pressure regulator	For regulating intake air volume.
19	Battery	For electrically starting engine.

2.Part Names

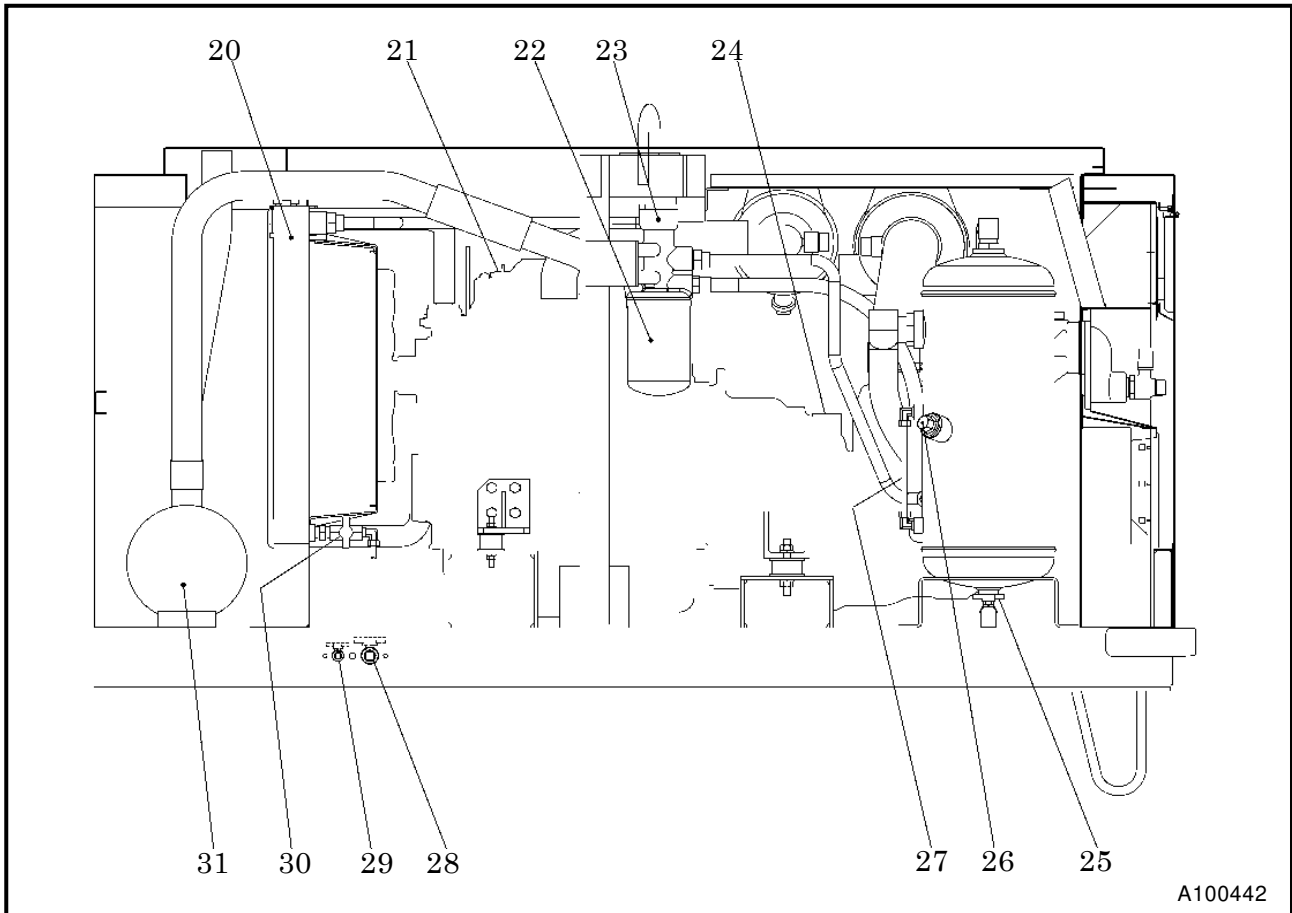

No.	Description	Function
20	Oil cooler	For cooling compressor oil circulating in the system.
21	Engine	For driving the compressor.
22	Compressor oil filter	For filtering compressor oil circulating in the system.
23	By-pass valve	For keeping compressor oil at proper temperature.
24	Air-end	For compressing intake air.
25	Separator receiver tank drain valve	From this portion where condensate is drained out of separator-receiver tank.
26	Compressor oil filler port	For supplying and replenishing compressor oil.
27	Compressor oil level gauge	Scale for measuring compressor oil level.
28	Engine oil drain valve	For draining engine oil for replacement of it and for maintenance.
29	Coolant drain valve	For draining condensate from engine.
30	Oil cooler drain valve	For draining compressor oil out of oil cooler and oil lines.
31	Exhaust muffler	Equipment which muffles an engine exhaust sound.

3. Installation

3.1 Transportation



Transportation

- When loading and unloading unit, be sure to use the lifting bail provided on the center of the unit top.
- Never get under the unit which is lifted up, because it is very dangerous.
- When unit is transferred or moved from working site, be sure to place it on truck bed, and fasten it by ropes at the front eye and rear stand.
- Never lift unit which is still in operation, or it could cause critical damage to each component or lead to serious accident.

3.1.1 Lifting up

- ① Before lifting the unit up, make sure to check the lifting bail for any crack and loosened bolts.
- ② Connect the hook “1” of the crane or shackle with lifting bail “2” eye fitted at the top center of the unit, and make sure that there is no person standing around the unit. Then perform hoisting operation.
- ③ Select a truck or a crane with capacity sufficient for weight and size of the unit by referring to the values shown in Chapter 8 “Specifications” of the manual.

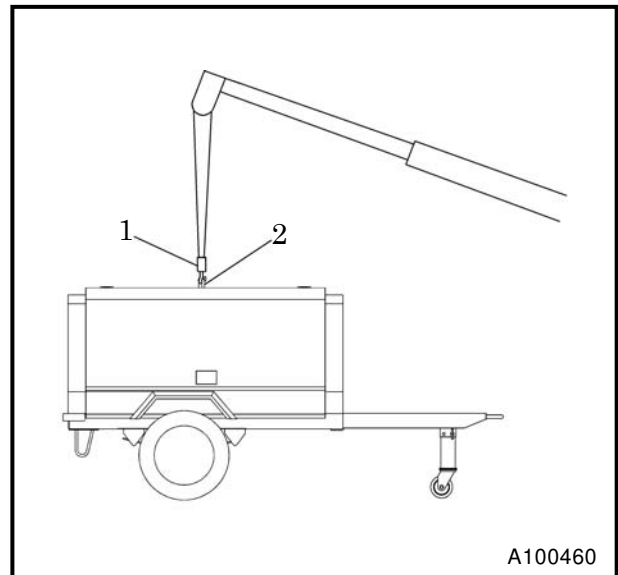

A100460

3.1.2 Mounting the unit on the truck bed

- Be sure to fasten the unit with ropes “1” as shown in the right figure, and securely fix it on the truck bed.
- Be sure to put one set of chocks “2” to the wheels.

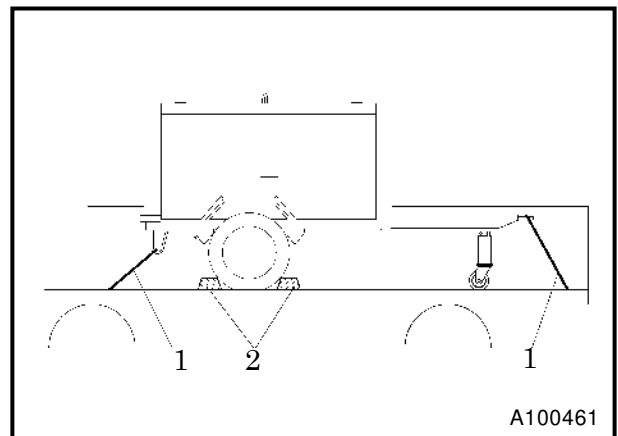

A100461

3. Installation

3.2 Towing the Unit

WARNING

- When towing unit, make sure there is no person or obstacle at both front and rear sides and under the unit.
- Although the machine is designed to be drawn, drawing is allowed only in construction site.
- Towing speed should be within 12.4mile/h.
- When drawing the compressor, make sure to retract the castor. Drawing the compressor with the castor not retracted, and drawing it using the castor can lead to serious accidents or damaged to the castor.

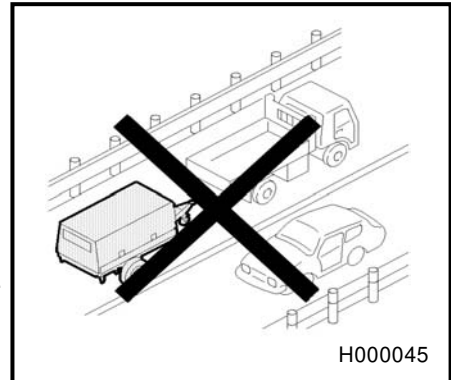

CAUTION

Caution for towing unit

- Be sure to use a vehicle with enough capacity to tow the unit in operating weight.
- Standard pressure for a tire is at 65psi (4.5bar).
- Be sure not to use wrong size or type of tire in changing.
- Make sure that the end of the drawbar is so surely and firmly connected to the coupler of the towing vehicle that the disconnection may not occur while the unit is being towed.
- Make sure if there is no deform or damage on the drawing vehicle and the drawbar of the unit.
- Be sure to keep your hand or finger away from any part of the coupling device when coupling or uncoupling a drawing device to a draw bar.
- Be sure to drive the drawing vehicle safely, avoiding dangerous place or ground, if any.
- If you do not follow the above instructions, it could cause serious injury or big damage.

3. Installation

3.3 Installation

WARNING

- Exhaust gas from the engine is poisonous, and could cause death when inhaled.
Avoid using the machine in an insufficiently ventilated building or tunnel.
- Do not position the exhaust gas outlet in direction of a person or a house.

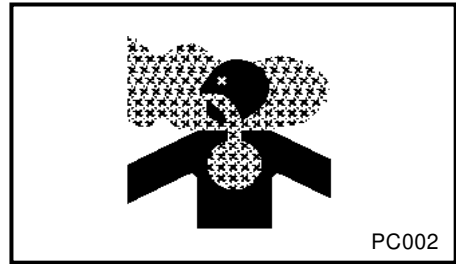

- The machine should be operated in following conditions:
 - **Ambient temperature** 5°F to 104°F (-15°C ~ +40°C)
 - **Humidity** Less than 90%
 - **Altitude** Lower than 4,921ft above sea level
- Install the machine in a place with good ventilation, lower temperature and with surroundings as dry as possible.
- If more than two machines are placed parallel in operation, keep enough distance so that exhaust air from one machine does not effect the other one.
- Also, a machine has to be installed in the environment where fresh air is always available.
- Keep enough space around the unit for inspection and maintenance access.

3.3.1 Installation

WARNING

- The machine has to be parked horizontally on a level place.
- In case the machine has to be parked on a slope, place it across grade so that the machine does not tend to roll downhill.
- Following grades on a slope for the machine are recommended within 15° degrees.
- In case of trailer type, be sure to put one set of chocks "1" to the wheels.

Installation

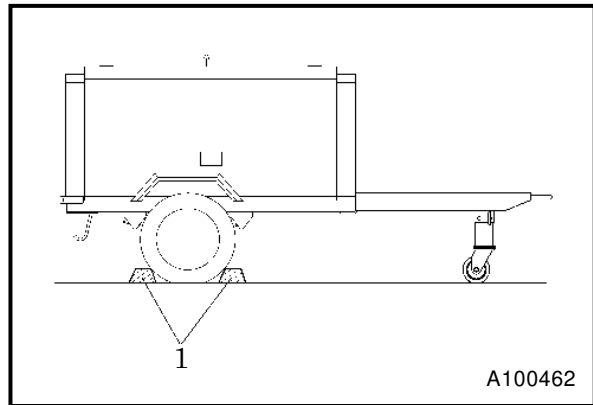

3.3.2 Service valve

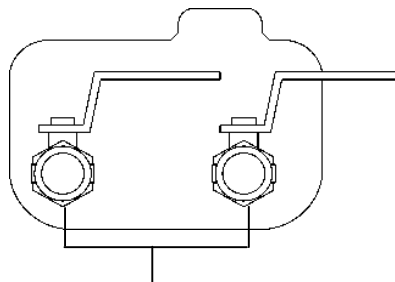

Discharge port : 20A(Rc3/4B) × 2
[Taper male screw]

A100443

4. Operation

4.1 Instrument Panel

Each display of the operation panel is illustrated as follows.

Read and fully understand the explanations and be sure to operate safely:

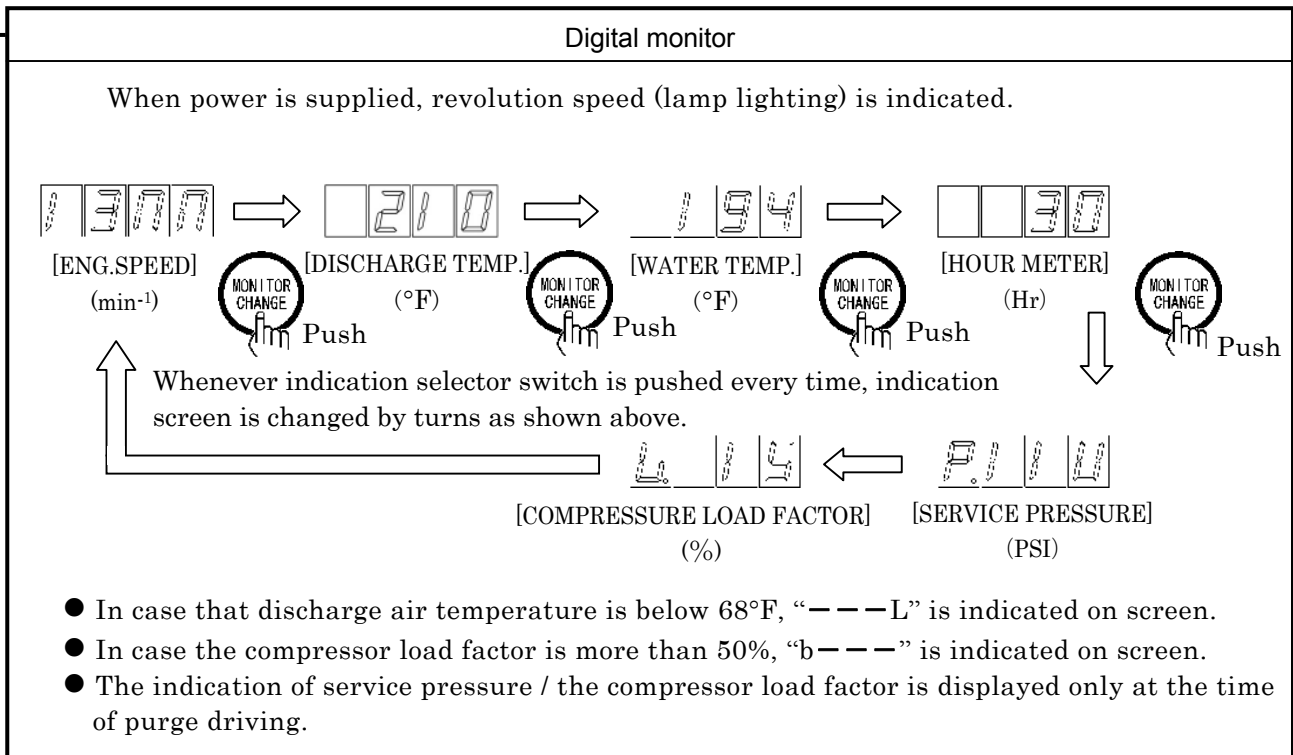
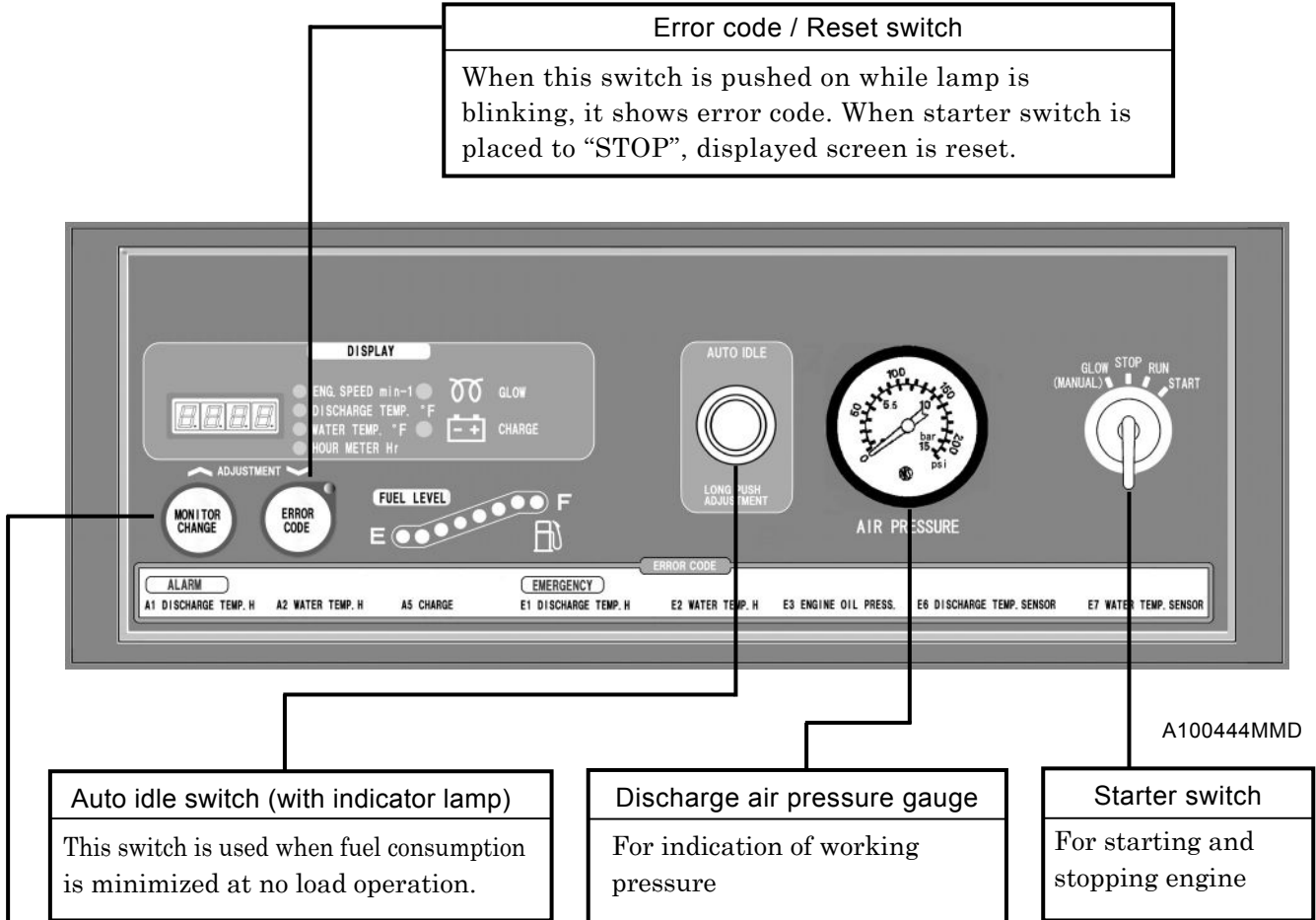

4. Operation

4.2 Lubricating oil · Coolant · Fuel

4.2.1 Engine oil

IMPORTANT

- Viscosity of engine oil greatly affects startability, performance, oil consumption of the engine, as well as wear of the moving parts.
- Choose appropriate oil based upon the table below according to the outside air temperature.

Ambient temperature range and oil viscosity (SAE)

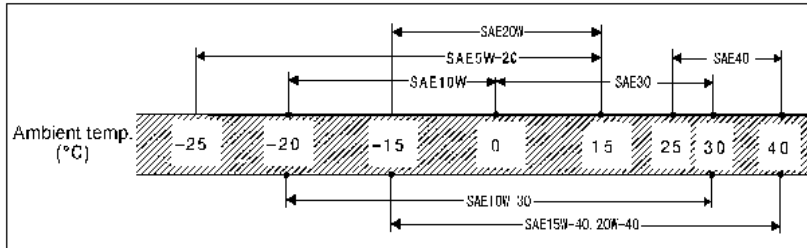

A100293E

- Use engine oil recommended by us.

Classification	API service classification CD class or higher
Viscosity	SAE10W-30

- Be sure to use CD class engine oil or superior class. (Using engine oil with poor quality may shorten the life of the engine).
- Follow the designated regulations to dispose of engine oil.

*** Unit is delivered ex. factory, filled with engine oil recommended by engine manufacturer.**

4.2.2 Compressor oil

IMPORTANT

Do not mix compressor oil

- Be sure to use recommended oil listed below.

Maker and Brand of Recommended Oil

Maker	Brand
HULS	ANDEROL 3032
MOBIL	RARUS SHC 1024
TEXACO	SYN-STAR DE32

- Even continuous oil replenishment cannot improve its deteriorated condition. Be sure to change the oil completely at every scheduled interval.
- Do not mix it with other brand oil, or it will cause poor performance and shorten the life of the compressor oil. (But fresh compressor oil could accept a mixture of small amount of different brands.)
- Running the unit with old and deteriorated compressor oil will cause damage to bearings, or serious accident like ignition in a separator receiver tank. Be sure to change the oil completely at every scheduled interval.
- Follow the designated regulations to dispose of compressor oil.

*** Unit is delivered ex. factory, filled with "AIRMAN OIL LONG LIFE".**

4. Operation

4.2.3 Coolant

IMPORTANT

Quality of coolant and antifreeze

- Use soft water of good quality such as tap water for coolant.
- When water with dirt, sand, and/or dust contained, or hard water such as well water (ground water) is used, this will cause deposits inside radiator or on cylinder head, and will cause engine overheat due to poor flow of coolant.
- When the unit is used in a cold region and possible freezing is expected, it is recommended to use LLC (Antifreeze) for the coolant.
- Adjust mixing ratio of LLC (Antifreeze) with water according to the temperature.
- Use LLC (Antifreeze) within the range of its mixing ratio between 35 and 60%.
- If LLC (Antifreeze) in the water exceeds more than 60%, it may decrease its antifreezing effect.
(Upon delivery from the works, LLC density is 55%)
- Follow the designated regulations to dispose of LLC (Antifreeze).

4.2.4 Fuel

IMPORTANT

Choose appropriate

- Be sure to use diesel fuel oil.
(Using other oil will cause low power output or damage the engine.)
- As for fuel, use diesel fuel oil (having higher than 45 cetane number).
- Use of diesel fuel oil having lower than 45 cetane number will cause inferior function to engine and, what is worse, it will cause serious accident to the engine.

4. Operation

4.3 Check before starting unit



Check before starting unit

- Be sure to check the unit before operation.
When any abnormality is found, be sure to repair it before restarting the unit.
- Be sure to make daily checks before operation. If the unit is operated without prior check and without noticing its abnormality, such operation could cause seizure of components or may even cause fire.

4.3.1 Check engine oil level

- Unit should be on level before checking oil level.
- When you check oil level after you have once started operation, wait 10 to 20 minutes after stopping engine, before checking the oil level.

<Procedure>

- ① Pull out the oil level gauge “1”, and wipe it with a clean cloth.
 - ② Then, re-insert the oil level gauge “1” fully and pull it out again. If the oil level gauge “1” shows the oil level between LOW and HIGH, it is normal.
 - ③ When the oil level is below its LOW, add engine oil from oil filler port “2” .
- While checking oil level, check also for contamination. If the oil is found dirty, contaminated or should it be changed according to the periodic inspection list, change the oil. **(See 5.5.1)**
 - Never fill oil more than HIGH level.

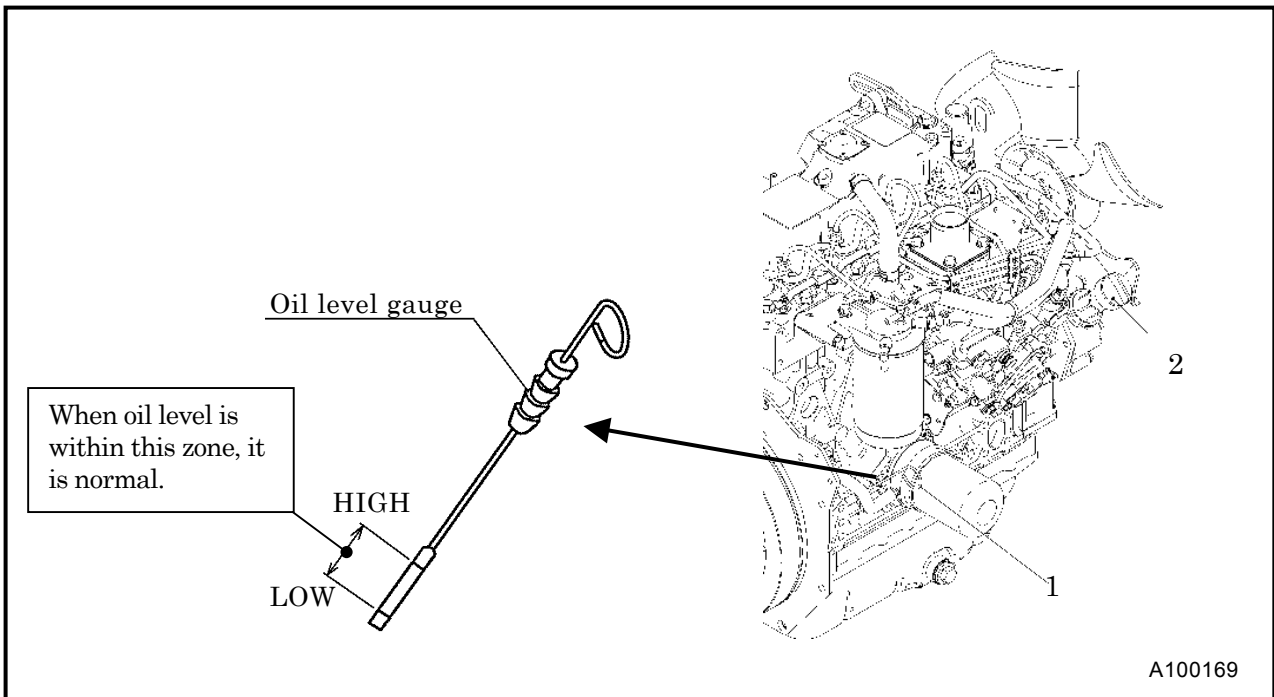

4. Operation

4.3.2 Check coolant level

CAUTION

- Be sure to stop the machine and allow time to cool. Then loosen the radiator cap one notch. After the coolant water is sufficiently cooled and the inner pressure is released, take the cap off. If this procedure is neglected, the inner pressure can blow off the cap. Steam jetting out of the radiator could result in causing scalding. Follow this procedure under all circumstances.

Taking off the radiator cap

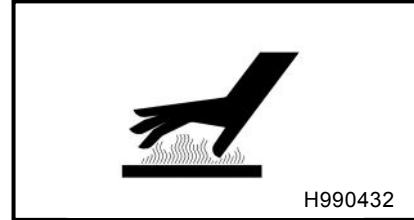

IMPORTANT

- Do not continue operation at low coolant level. Air bubble is mixed into radiator, and it causes damage to the radiator.

- Check the coolant level in the reserve tank. If it is lower than the limit, open the cap and replenish the coolant. (Level must be kept above LOW mark.)
- When there is a little water or no water in the reserve tank, remove the radiator cap and make sure to check the water level. Then supply coolant to the radiator and also the reserve tank, if necessary. (See 5.5.17)

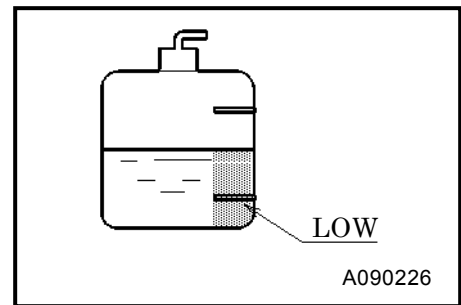

4.3.3 Check compressor oil level

WARNING

- When you refill the separator receiver tank with compressor oil, stop the engine, and make sure that the pressure gauge indicates 0psi (0bar) and there is no residual pressure in it, and then gradually loosen the oil filler cap for refilling oil.
- Should any residual pressure be left in the separator receiver tank, hot compressed air and hot compressor oil jetting out could cause burning or serious injury to persons nearby.

Refilling of compressor oil

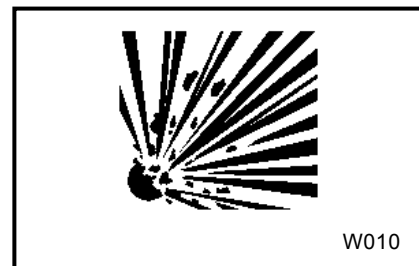

- Place the machine on level ground when checking the oil level.
- Check the oil level of the compressor. Correct oil level is between upper and lower limit of the gauge, when the unit stops. If the gauge shows lower than the middle level, replenish oil. (See 5.5.5)
(Oil level drops when starting operation.)

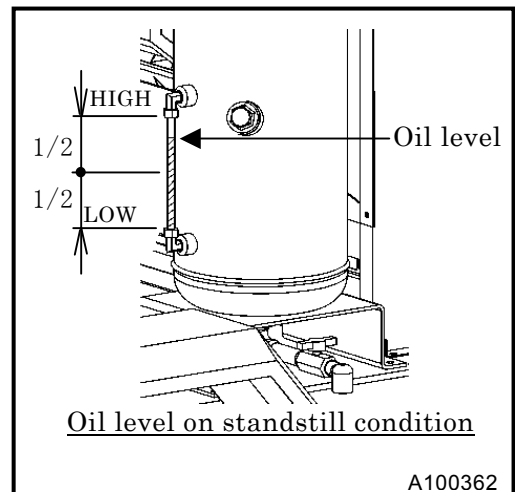

4. Operation

4.3.4 Drain separator receiver tank



WARNING

Draining of Separator receiver tank

- After stopping the engine, confirm that the pressure gauge indicates 0psi (0bar) and there is no residual pressure in it, then open the drain valve gradually to drain the compressor oil.
- Note residual pressure in the receiver tank could force both extremely hot compressed air and oil to jet out and you may be scalded or seriously injured.

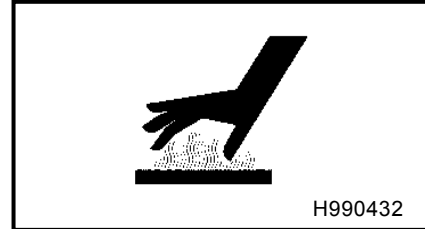

- Gradually opening the drain valve “2” fitted under the separator receiver tank “1” as shown in the fig, drain the condensate.
- Be careful not to fully open the drain valve “2” . Otherwise, much oil may be lost.
- After draining the oil completely, close the drain valve “2” firmly.
- Drain the condensate in container “3” , and then dispose of condensate according to the designated regulations.
- Touch the fluid and check its viscosity to determine whether it is condensate or compressor oil, and when it is difficult to distinguish between the two.

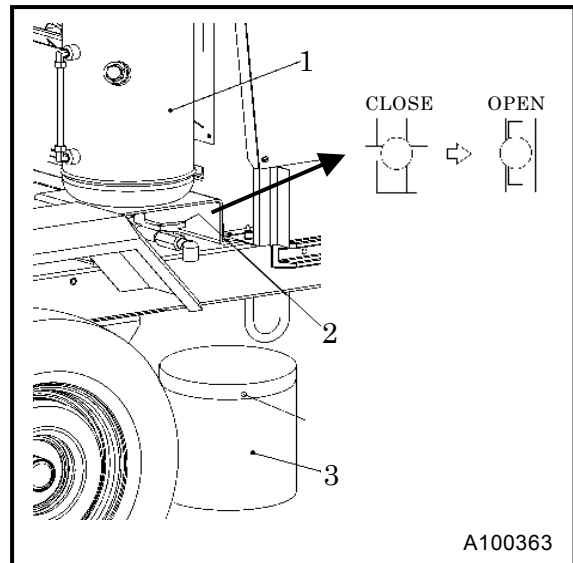

4.3.5 Check fuel

- Before starting operation, make sure to check the level of residual fuel so that fuel shortage during operation can be avoided.
- Drain condensate accumulated at the bottom of fuel tank whenever necessary.



CAUTION

Fire prevention

- Do not, under any circumstance, bring lit cigarettes and/or matches to the fuel.
- The fuel is extremely flammable and dangerous. Be careful of fire because it is very likely to catch fire.
- Refuel only after stopping the engine, and never leave open fuel can near the machine. Do not spill. It could cause a fire. When it is spilt, wipe it up completely.
- Refilling fuel tank should be done in an outdoor well-ventilated place.
- Do not fill fuel oil up to the cap lever. When fuel tank is filled up to the cap level, fuel oil will be overfilled due to volume expansion caused by rise of ambient temperature. Further, fuel will be possibly spilled from fuel tank due to vibration caused during movement and/or transportation of machine.



4. Operation

4.3.6 Drain fuel tank

- Opening the drain valve “2” fitted under the fuel tank “1”, drain the condensate from the tank.
- When completely drained, firmly close the drain valve “2” .
- Drain the condensate in container “3”, and then dispose of condensate according to the designated regulations.

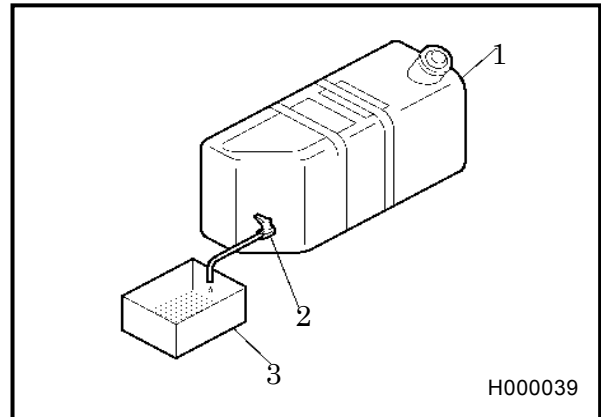

4.3.7 Check sedimenter for condensate

When red float “2” under element “1” in fuel filter is raised up to upper level, drain water.

<Draining procedure>

- ① Turn fuel selector valve “3” to “OFF” position.
 - ② Loosen the drain valve “4” and drain out condensed water inside.
 - ③ Make sure to tighten the drain valve “4” securely, after draining the condensate.
- Drain the condensate in container “5”, and then dispose of condensate according to the designated regulations.

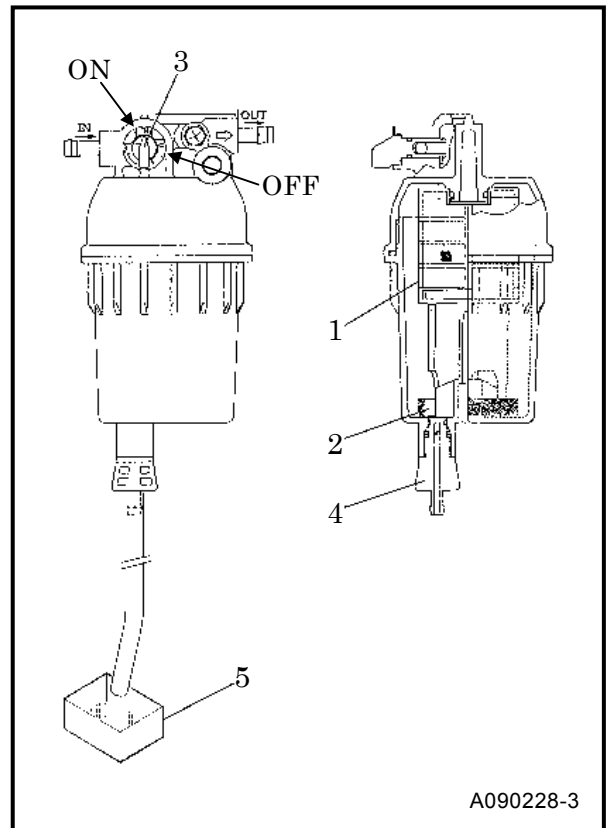

4.3.8 Check wiring of each part

Check each wiring for any loose connection, damage to insulating sheathed portion, disconnection, and short-circuit.

4.3.9 Check piping of each part

Check each piping for any loose connection and also check each hose and pipe for any tear and leaks.

4. Operation

4.3.10 Check belt tension

IMPORTANT

- Too tight belt tension could damage shaft and shorten bearing life. Too loose belt tension may result in damaging belt earlier and machine components due to overheat.

- Follow the procedure below to adjust tension of fan belt and belt for alternator.
- Adjust the tension by gradually loosening the fastening bolt of the alternator.

<Procedure>

- ① Visually check if there are any cracks or tears in the belt.
- ② Adjust the belt tension by loosening the fixing bolt “1” of the alternator so that the belt can deflect 0.39 to 0.55 in. (10 to 14mm) when pressed at the center of the belt with approx. 22lbf (98N) force.
- ③ Be careful not to leave any grease or LLC on a belt while changing it. If any such material is left, wipe it off completely.

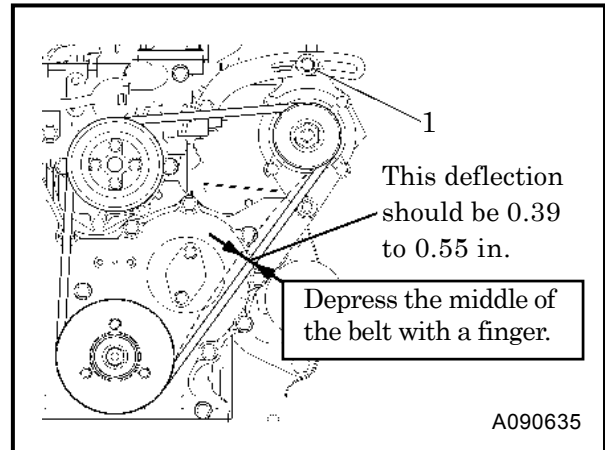

4.4 Operation

CAUTION

Operation with compressed air supply port opened is prohibited

- Do not operate the machine with service valves and relief valve open unless air hoses and/or pipes are connected. High-pressurized air blows out and its air pressure could cause injury to the people nearby.
- When the machine has to be unavoidably temporarily operated with its port open, be sure to mount a silencer to reduce noise and wear protective materials such as earplugs to prevent damage to hearing.

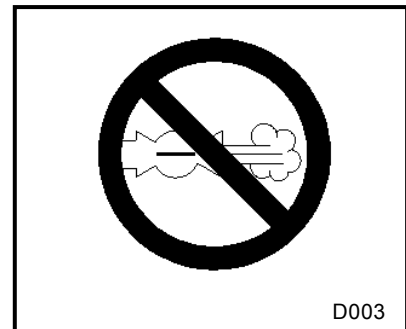

WARNING

- Keep the door closed and locked while running the unit.
- When the door has to be opened, be careful not to touch portions that are rotating or very hot. Careless touch may cause serious injury.
- Pull the handle forward to open the door.
- Be sure to close the door tightly so that its latch is firmly caught.

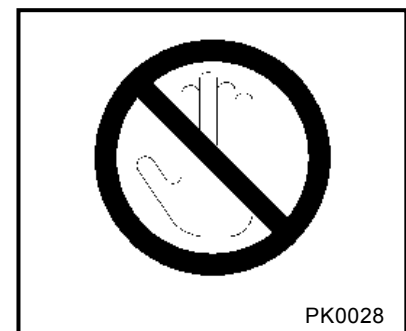

4. Operation

4.4.1 Procedure to start the unit

IMPORTANT

Be sure to warm-up

- Be sure to let unit warm-up after starting for smooth operation of the engine and the compressor. Do not operate the engine at full load immediately after it starts up. This will shorten the equipment life.
- During the warm-up operation, examine the different parts of the equipment for any looseness, leakage of water, oil, fuel, and other irregularities. Also, make sure that monitor lamps are off.

<Procedure>

- ① Close fully service valve.
- ② Turn the starter switch “1” to “RUN” position, and the glow lamp “2” goes on.
- ③ As soon as the glow lamp “2” has gone out, turn the starter switch “1” fully clockwise to start up the engine. (After starting, unload operation automatically begins.)

According to engine cooling water temperature, the times in the following table are required.

Engine coolant temperature	Required time for preheating	Required time for starting unloader operation
Higher than 32°F	2 sec	5 sec
Lower than 32°F	20 sec	Shorter time either 120 seconds or the time when engine coolant temperature becomes higher than 32°F.

- ④ Once the engine has started up, leave it running to warm-up for 5 minutes. The discharge air pressure gauge “3” in this condition ranges from 44 to 102 psi (3 to 7 bar).
- ⑤ After finishing warming up operation, open the service valve provided at the outlet of compressed air and start service job.

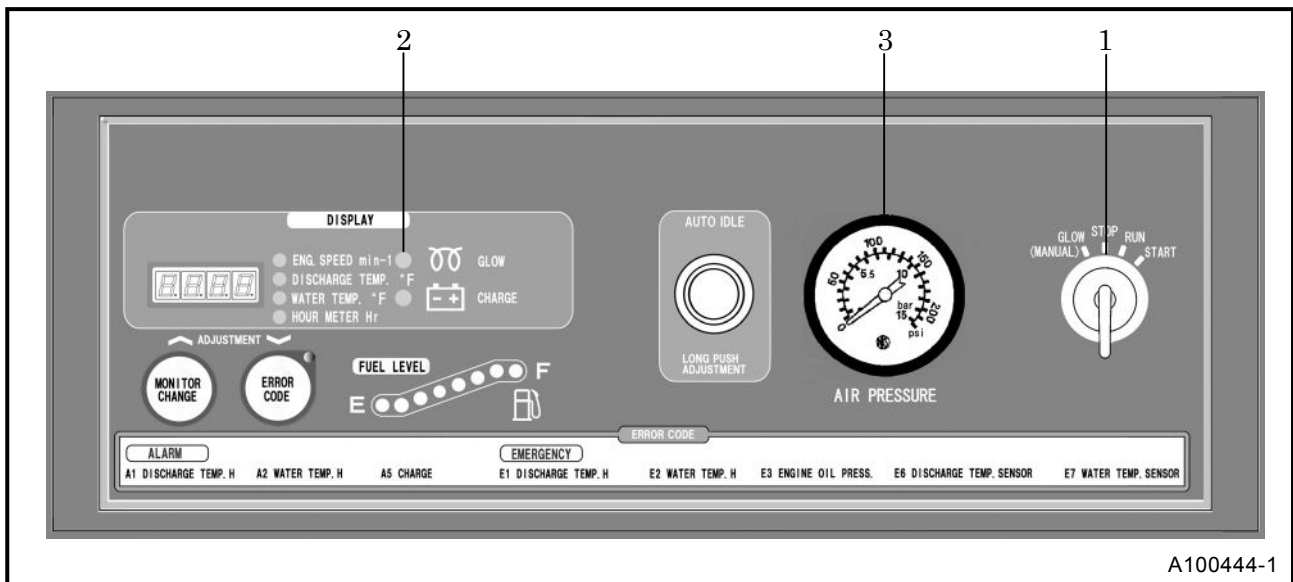

A100444-1

4.4.2 Operating procedures when engine fails to start up on first attempt

- When the engine fails to start up even after performing the startup procedures ① to ③, do not keep the starter running, but set the starter switch back to “STOP” and wait about 30 seconds. Then, repeat the startup procedure once again.
- If the repeated procedure does not allow the engine to run, the following causes are suspected. Therefore, check the following:
 - No fuel
 - Clogging of fuel filter
 - Discharge of battery (Low cranking speed)
 - Ambient temperature is too low.

4. Operation

4.4.3 How to start the unit at low temperature

IMPORTANT

Operation under Cold Weather Conditions below 23°F(-5°C)

- Use SAE10W-30 (CD class) for the engine oil.
- Use LLC (antifreeze). Use correct amount to provide freeze protection, according to the ambient temperature.
- Battery should always be kept fully charged.

When it is difficult to start engine in cold weather, take the following measures.

<Procedure>

- ① Fully close the service valve, and fully open the low temperature starting valve “1” which is provided at the top of separator receiver tank for starting under the conditions of low temperature.
- ② Perform normal starting operation first and gradually close the low temperature starting air valve “1”, watching the rising engine speed.

[Caution]

In case that it is difficult to start engine even after having tried the above mentioned procedures, turn starter switch “2” to “GLOW” for preheating. (But glow lamp “3”)

※Never try this procedure continuously longer than 20 seconds.

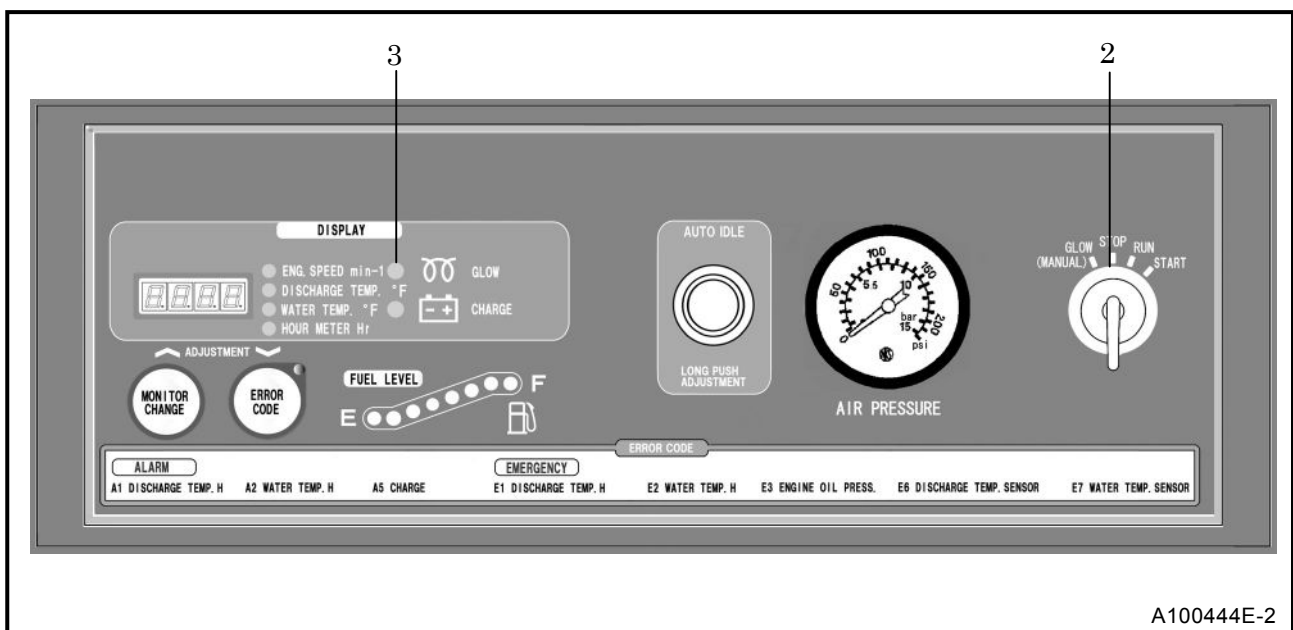
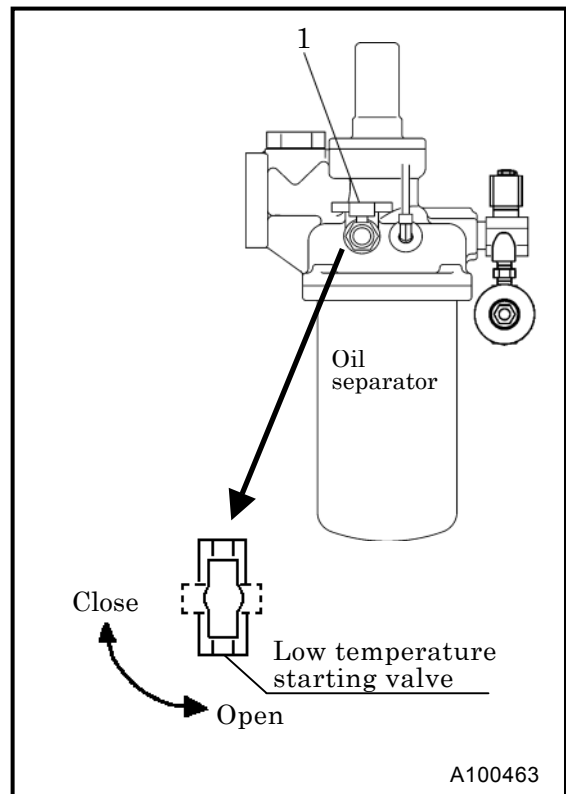



4. Operation

4.4.4 Gauge Indication while operating

IMPORTANT

- Minimum discharge air pressure is 58psi (4bar) during operation.
- Continuing equipment operation at a lower pressure than the above pressure may cause overheating, since it affects the separation of lubricating oil inside the oil separator and reduces the oil flow to the compressor air-end, resulting in temperature rise.

- Be sure to check at times to see if gauges or each component of the unit are properly working, or if there is any air-leak, oil-leak, water-leak or fuel-leak etc.
- During normal operation, each indication of instruments is shown in the table below. Refer to the table for daily checks.
- The above table gives standard values. They may vary slightly depending on the operating conditions and other factors.

Protection device		Indicator lamp		
		GLOW	CHARGE	Auto idle
Monitor				AUTO IDLE
Starting	Starter switch set to "RUN" position	● OFF ※	 ON	● OFF
In operation		● OFF		

		Discharge pressure gauge
In operation	Full load	58 to 100 psi (4 to 6.9 bar)
	No load (Unload)	104 to 131 psi (7.2 to 9.0 bar)
	At purge control (AUTO IDLE)	58 to 73 psi (4.0 to 5.0 bar)

※This lamp will be OFF in 0 to 20 seconds, (varying upon ambient temperature.)

4. Operation

4.5 Capacity Control Device

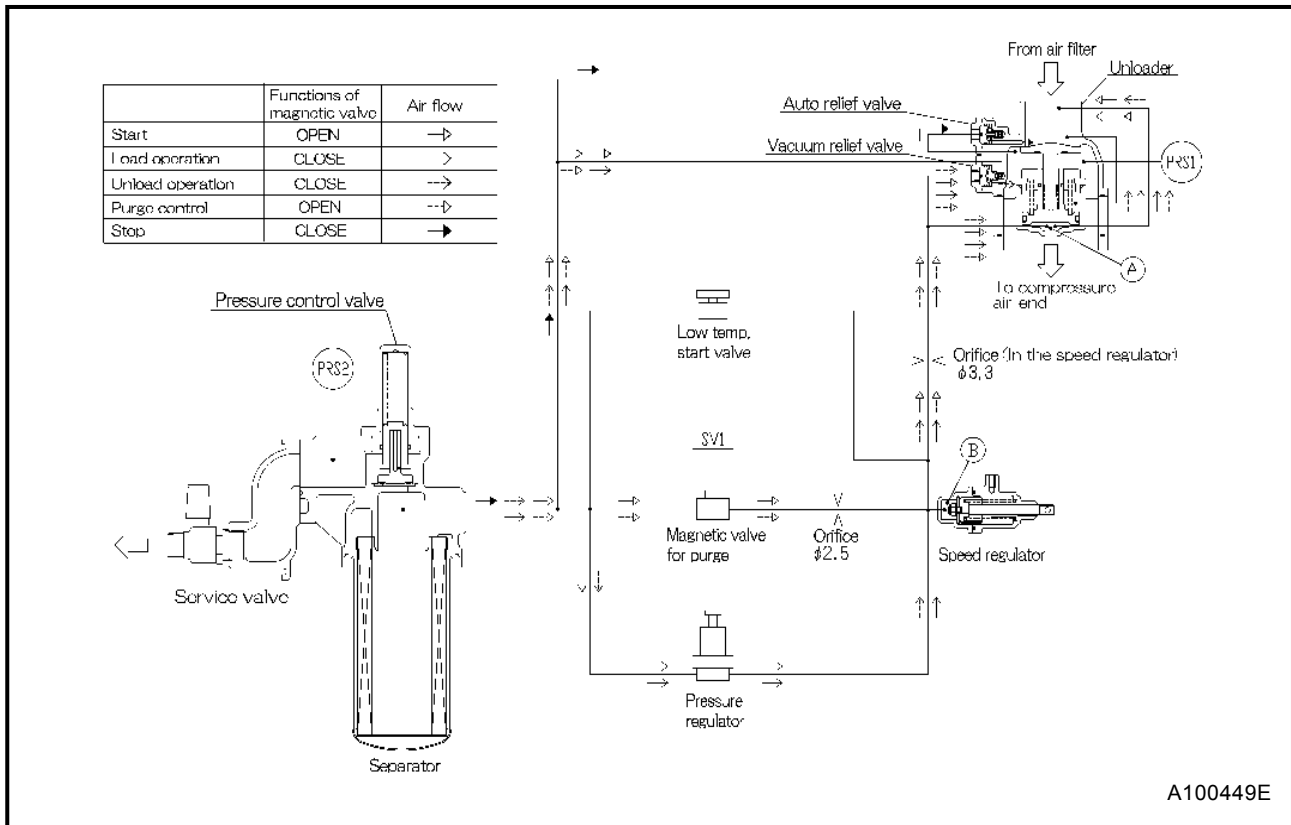

Step	Response
Start	When starting operation, purge solenoid valve SV1 opens. And compressed air is sent to unloader chamber (A) and speed regulator chamber (B). The pressure in chamber (A) rises soon, and unloader valve fully closes due to low pressure. Thus the load required for starting is reduced.
Load operation	After the unit starts, it automatically performs unloaded operation and then solenoid valve SV1 closes. As discharge pressure increases and decreases, air flow from pressure regulator to the chamber (A) and (B) increases and decreases. Thus, unloader valve position and engine speed changes, and accordingly it regulates delivery air steplessly from 0 to 100 %
Suction port closing unload operation	When air consumption is reduced, and the pressure exceeds the rated one, speed regulator functions to lower the engine speed in proportion to the pressure rise and, at the same time, to close unloader valve. Under unloaded operation, the interior of compressor air-end becomes vacuum and vacuum noise is caused. In order to prevent occurrence of vacuum noise, it functions to open the vacuum relief valve, detecting the secondary pressure of pressure regulator and thus it prevents high vacuum state inside the compressor air end from being caused.

4.Operation

4.5.1 AUTO IDLE control (Purge control)

This model is equipped with auto idle control operation mode. This operation mode is recommendable for such use: not so much air consumption is required and it is used continuously and also power consumption under unloaded operation is required to be saved. Use this mode, depending upon the need and demand. For the selection of this mode, switch on “AUTO IDLE” on the operation panel. Select this operation mode freely, according to required air consumption.

<Procedure>

- ① During operation, push on the switch “1” “AUTO IDLE”.
- ② Then the indicator lamp auto idle “2” goes on.
- ③ In order to stop this operation mode, push again auto idle switch “1” and then the lamp “2” goes out to disengage this purge control.

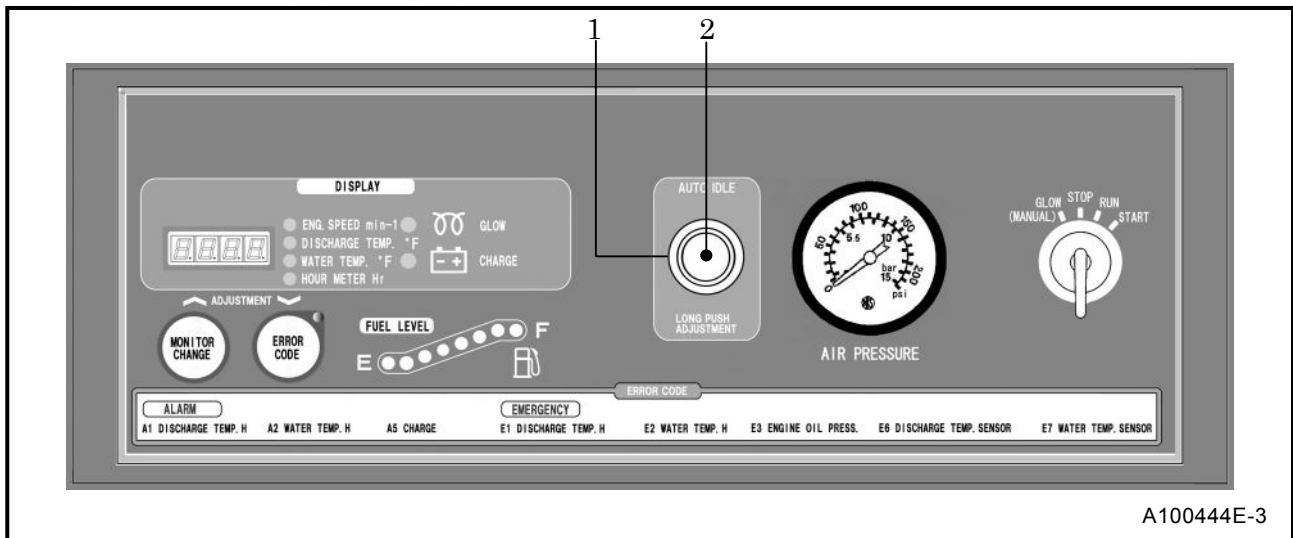

[Function of auto idle control (Purge control)]

Function	Conditions of auto idle lamp
① First engine speed drops to the minimum speed by pressure regulator, owing to reduction of air consumption. Later the air consumption is reduced further, the unloader valve gradually closes and intake negative pressure increases. In this stage, the pressure sensor detects the intake negative pressure. Then when the intake negative pressure becomes higher than the set pressure, the “AUTO IDLE” lamp flickers at short intervals.	Lamp flickers at short intervals.
② When this condition continues for a certain time, the solenoid valve functions to start purge mode operation. Consequently, the pressure inside separator receiver tank drops and reduces the power of compressor air end. In this stage, the lamp “AUTO IDLE” flickers at longer intervals.	Lamp flickers at longer intervals.
③ Next, when the pressure for load down to the purge releasing pressure owing to the increase of air consumption, the solenoid valve operation gets “OFF” and it is transferred to normal operation. In this stage, the lamp “AUTO IDLE” goes on.	Lamp goes on.

4.Operation

4.6 Stopping

<Procedure>

- ① Close the service valve completely and operate the machine about 5 minutes, until it cools down.
 - ② Turn the starter switch to “STOP” position to stop the engine.
 - ③ Remove the key from the compressor every time when you stop the engine. Keep the key and be careful not to lose it.
- Unless all the service valve are fully closed upon stopping operation, the compressed air will be sent in reverse direction in the hoses (pipes) connected to air tools and relieved to atmosphere continuously through the auto-relief valve. Further, when re-starting operation next time, compressed air will be jetted out through service valves.

4.7 Air bleeding in fuel line

Should the machine stop due to fuel shortage, perform air bleeding according to the following steps.

<Procedure>

- ① Replenish fuel.
- ② When starter switch is turned to “RUN” position, electromagnet pump starts to automatically bleed air in fuel line.
- ③ Air bleeding is completed about 1 minute.

5.Periodic Inspection/Maintenance

5.1 Important Items at Periodic Inspection and Maintenance or after Maintenance

The following table shows the inspection and maintenance intervals under normal operation conditions. When used or operated under hard environmental conditions, it is impossible to warrant the unit even if the above conditions are performed according to the intervals listed in the above table.



WARNING

Hang a "Now Checking and under Maintenance" tag

- Remove the starter key from the starter switch before starting inspection, and hang up a "Now Checking and under Maintenance" tag where it can be easily seen. The checker must keep the key during checking and maintenance.
- Remove the negative (-) side cable from the battery. If the above procedure is neglected, and another person starts operating the machine during check or maintenance, it could cause serious injury.
- Use tools appropriate for the inspection and maintenance. Any makeshift or improper tools could cause unexpectedly injury by their slippage.

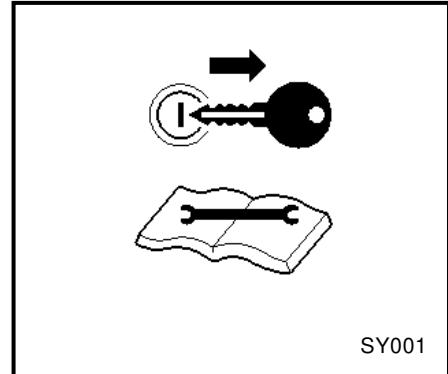

CAUTION

Prevention of oil separator from catching fire

- Be sure to perform oil change basically according to the specified interval. But if such oil is found much more contaminated before the interval, change the oil even before the specified period comes. In doing so, replace the oil completely and use our recommended oil.
- Be sure to perform following periodic inspection and maintenance:
 1. Check and change compressor oil
 2. Change oil separator
- Never mix the oil of different brands, or the mixed oil may deteriorate the oil quality.

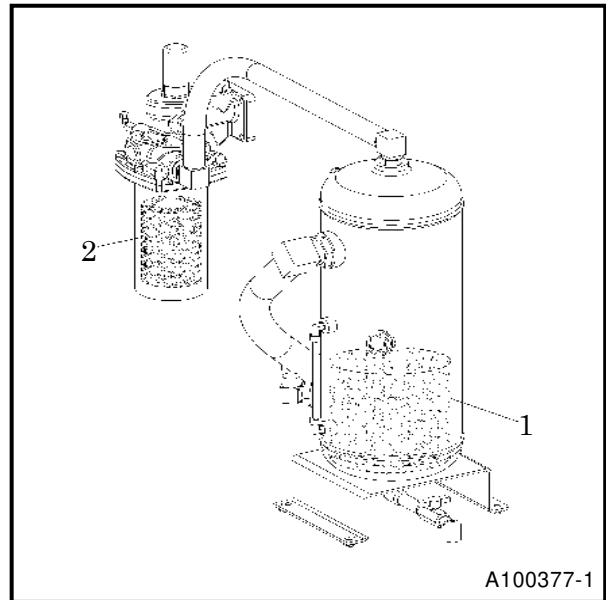

5.Periodic Inspection/Maintenance

IMPORTANT

Directions: Prohibition of any other jobs or works than directed herein

- Be sure to use recommended fuel, oil, grease, and antifreeze.
- Do not disassemble or adjust engine, compressor or part(s) for which inspection or maintenance is not referred to in this manual.
- Use genuine parts for replacement.
- Any breakdown, caused by using unapproved parts or by wrong handling, will be out of the scope of "WARRANTY".
- Keep the electrical components away from water or steam.
- Waste from machines contains harmful material. Do not dispose of such harmful fluids to the ground, rivers, lakes or ponds, and sea. It contaminates the environment.
- When draining waste fluid from machines, use leakproof containers to hold such fluids from machine.
- Be sure to follow the designated regulations when disposing of oil, fuel, coolant, filters, battery and other harmful things.

5.2 Daily Inspection and Operation Log

- Be sure to carry out daily inspection every morning before operation. See Chapter 4 "Operation" of the manual for the details of inspection.
- Pay attention to and carefully observe the following points during daily operation or inspection and maintenance work. If any trouble or abnormality is found, immediately investigate its cause and make repairs. If the cause is unknown or not traceable, or if the trouble involves a part or component not described in the manual, ask your nearest dealer for information.

- (a) Controls and instruments function properly.
- (b) Quantity and any leak of water, fuel, and oil or any contamination should be checked.
- (c) Appearance, abnormal noise or excessive heat should be checked.
- (d) Loose bolt or nut should be checked.
- (e) Any damage, wear or shortage of machine components and parts should be checked.
- (f) Performance of each part or component should be proper.

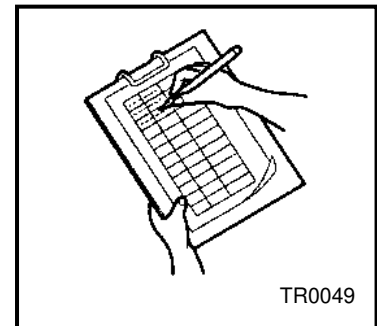

- Keep the operation log to record constant inspection of each component, so that trouble of the unit can be easily discovered and preventive measures can be taken.
It is very useful to record information such as discharge pressure, oil level, as well as running hour, maintenance items and replenishment of lubricant on a daily maintenance log.

5.Periodic Inspection/Maintenance

5.3 Periodic Inspection List

(Unit:Hour)

Maintenance	Daily	Every 250	Every 300	Every 500	Every 1,000	Every 2,000	Every 3,000	Every 8,000	Page
Compressor	Check compressor oil level.	○							4-5
	Drain separator receiver tank.	○							4-6
	Check looseness in pipe connecting part, and wear and tear of pipe.	○							4-7
	Check oil, water, fuel and air leak.	○							4-11
	Check functions of all instruments and devices.	○							4-11
	Change compressor oil.			○ First time	○				5-8
	Change compressor oil filter.			○ First time		○			5-9
	Clean strainer in the scavenging orifice.				○				5-9
	Clean and change air filter element.		○ (Clean)		○ (Change)				5-7
	Clean outside of the oil cooler.					○			5-11
	Change diaphragm of speed regulator.					☆●			5-11
	Change oil separator.						●		5-14
	Change nylon tubes.						☆●		5-13
	Change o-ring of unloader.							★●	5-15
	Change pressure regulator.							●	5-14
	Check rubber hose.							★●	5-15
	Check o-ring and needle valve of auto-relief valve.							★●	5-16
	Check o-ring and needle valve of vacuum relief valve.							★●	5-16
	Performance check of pressure control valve.							●	5-16
	Check and change o-ring and piston of pressure control valve.							●	5-17
Check solenoid valve. (In case no abnormality is found, it can be used again.)							●		
Change oil seal and bearing.								●	

Such items marked ○ shall be carried out by customers.

For the following items or clauses marked ●, contact us directly or our distributors because they require expert technical knowledge on them.

The items or parts marked ☆ should be replaced every 2 years even if they are not in disorder within their periodical maintenance interval because their materials will change or become degraded as time passes.

Also for the same reason, the parts marked ★ should be replaced every 3 years.

5.Periodic Inspection/Maintenance

◎Refer to engine operation manual for inspection and maintenance of an engine.

(Unit:Hour)

Maintenance	Daily	Every 50	Every 250	Every 500	Every 1,000	Every 2,000	Every 3,000	Page	
Engine	Drain fuel tank.	○						4-7	
	Check sedimenter for condensate.	○						4-7	
	Check fuel.	○						4-6	
	Check engine oil level.	○						4-4	
	Check coolant level.	○						4-5	
	Check looseness in pipe connectors, terminals and tear in wiring.	○						4-7	
	Check belt tension.	○						4-8	
	Change engine oil.		○ First time	○					5-6
	Change engine oil filter.		○ First time	○					5-6
	Check battery electrolyte.			○					5-7
	Clean and change air-filter element.			○ (Clean)	○ (Change)				5-7
	Clean of element in sedimenter.				○				5-10
	Change fuel filter.				○				5-10
	Change coolant.					☆○			5-12
	Clean outside of radiator.					○			5-11
	Clean inside of radiator.					●			5-11
	Change fuel hose.						☆●		5-13
	Clean inside of fuel tank.						●		
Change radiator hoses.							★●	5-15	

The items or parts marked ☆ should be replaced every 2 years even if they are not in disorder within their periodical maintenance interval because their materials will change or become degraded as time passes. Also for the same reason, the parts marked ★ should be replaced every 3 years.

Maintenance	Daily	Every 250	Every 300	Every 500	Every 1,000	Every 2,000	Every 3,000	Page
Undercarriage	Supply grease to trailer hub bearing.				○			5-12
	Supply grease to reif spring pin.				○			5-12
	Check and confirm that drawbar is properly fixed with bolts properly, according to specified tightening torque.			○ Every 3 months				5-17
	Check and confirm that the bolts with which undercarriage brackets are fixed are properly tightened.			○ Every 3 months				5-17
	Check and confirm that the nuts with which tires are fixed are properly tightened.			○ Every 3 months				5-18

5.Periodic Inspection/Maintenance

5.4 Periodic Replacement of Parts

- Part number changes upon modification. For replacement of parts, make sure whether the part number is correct or applicable.

Part Name		Part Number	Quantity
Engine oil filter		41290 01100 (YANMAR 119005-35151)	1
Compressor oil filter		37438 08900	1
Air filter element	For compressor air-end	32143 11800	1
	For engine	32143 11700	1
Fuel filter		43543 01400 (YANMAR 129907-55801)	1
Element in sedimenter	Element	YANMAR 129242-55730	1
	O-ring (For element)	YANMAR 24311-000160	1
	O-ring (For body)	YANMAR 24321-000750	1
Oil separator	Separator	34220 16101	1
	O-ring	03402 15140	1
Diaphragm for speed regulator		36437 01500	1
Pressure regulator		36400 19000	1
Auto-relief valve & vacuum relief valve	O-ring "1"	03402 25021	2
	O-ring "2"	03402 25008	2
	O-ring "3"	21221 02100	2
	Needle valve "4"	36429 00801	2
Unloader valve	O-ring "1"	03402 10125	2
	O-ring "2"	03402 10070	1
	O-ring "3"	21221 04800	1
	O-ring "4"	21221 04900	1
Pressure control valve	O-ring "1"	03402 15075	1
	O-ring "2"	03402 25032	1
	Spring "3"	22144 07700	1
	Piston "4"	35303 03300	1
Solenoid valve	For starting unloader / For purge	46811 24100	1

5.Periodic Inspection/Maintenance

5.5 Maintenance Items

5.5.1 Change engine oil

[At 50 hours for the first change and at every 250 hours thereafter]



Caution in filling or discharging engine oil

- After stopping the engine, wait for 10 to 20 minutes until the engine oil cools off. Then check the level of the engine oil, or refill or drain the oil.
- Engine oil is very hot and highly pressurized during or just after the operation. Hot oil could blow out of the tank and can cause scalding.
- Never supply more engine oil than specified level. excessive supply of engine oil could cause emission of white smoke from exhaust port, too fast revolution of engine and it could cause damage to the internal parts of engine.



<Procedure>

- ① Remove the drain plug "1" attached outside the plane, open a drain valve "2" inside the plane, and discharge engine oil drain.
- ② When the oil is completely drained, close a drain valve "2" after attaching a drain plug "1", remove the cap of an engine oil filler port "3", refill new engine oil.

[Quantity of oil : approx. 2.0gal.(7.4L)]

- ③ After supplying oil, pull out the oil level gauge "4" and wipe it out.
- ④ Then, re-insert the oil level gauge "4" fully and pull it out again. If the dipstick shows the oil level between upper limit and lower limit, it is normal.

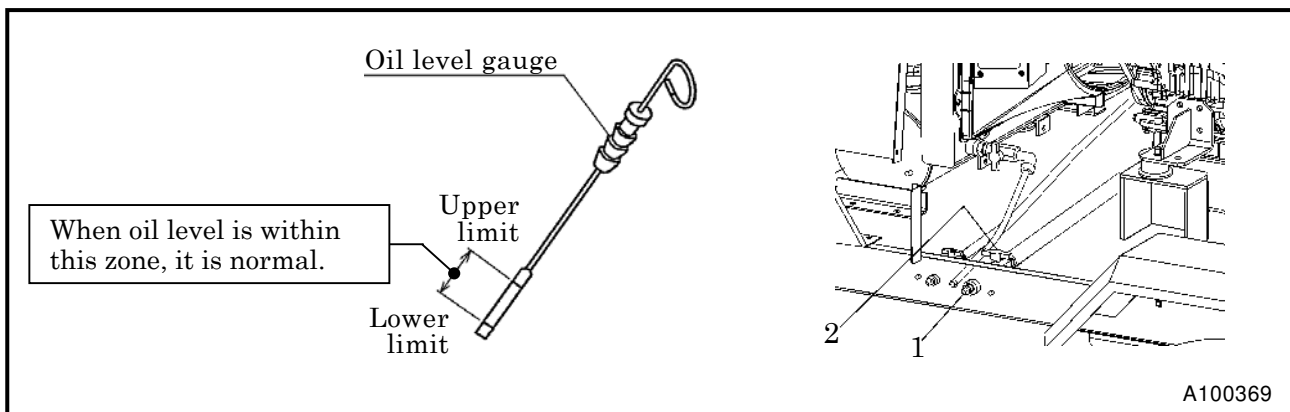
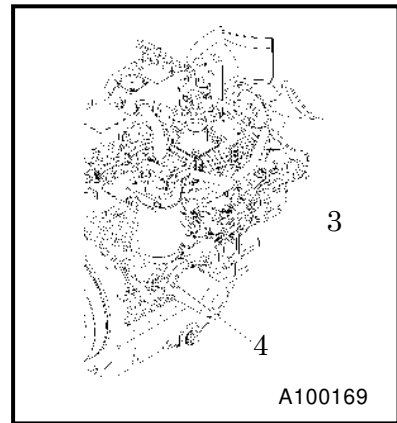

5.5.2 Change engine oil filter

[At 50 hours for the first change and at every 250 hours thereafter]

<Procedure>

- ① Remove the cartridge "1", using a filter wrench.
- ② Screw in the new cartridge "1" with the packing "2" coated slightly with oil. **(For part number, see 5.4)**
- ③ After the packing touches the sealing face, further tighten it by turning it 3/4 times with the filter wrench.
- ④ After installing the oil filter, check it for any leak during operation.

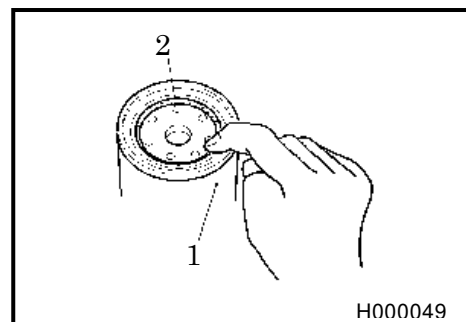

5.Periodic Inspection/Maintenance

5.5.3 Check battery electrolyte [Every 250 hours]

If there seems to be a problem in starting an engine due to a flat battery, carry out the checks by following the procedures below:

1. Ordinary type battery:

Check battery electrolyte level and if the level is not within the specified level, add distilled water.

Measure specific gravity of battery electrolyte, and if it shows below 1.24, recharge the battery immediately.

Refer to 6.1. for method of specific gravity measurement and recharging the battery.

2. Enclosed type battery:

Check the indicator on top surface of the battery.

If the indicator shows that charge is needed, recharge the battery immediately.

5.5.4 Check and clean air filter element [Every 250 hours]

IMPORTANT

Cleaning of air filter element should be perfectly performed

- Clogged or cracked or pitted element could allow entrance of dust into engine and compressor to cause earlier wear of moving parts. Periodical inspection and cleaning of element should be performed to maintain life of air-end and engine long.

<Procedure>

- ① After removing the cap "1" by loosening its latch "2", clean its interior properly.
 - ② Take out element "3" and clean it.
 - ③ When installing the cap "1" after finishing the cleaning job, push the element into the case "4" surely by hand, and then make sure that the latch "2" fixing the cap surely hooks the case "4". Finally tighten it.
- When the air filter clogging indicator "5" turns red, take the element out and clean it.
 - If the element is found heavily dusty, replace it with a new one. **(For part number, see 5.4)**

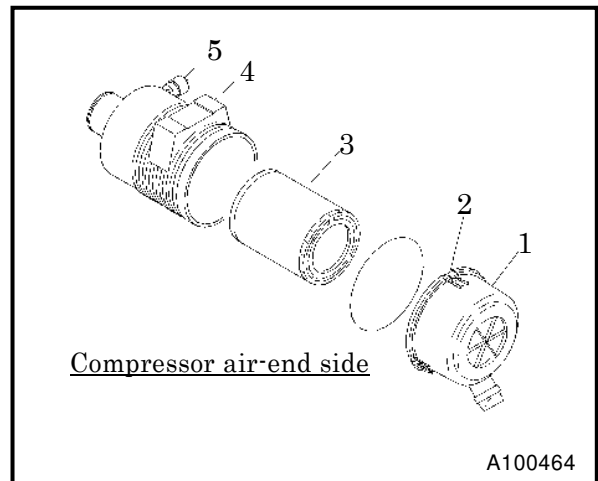

5.Periodic Inspection/Maintenance

5.5.5 Change compressor oil

[At 300 hours for the first change and at every 500 hours thereafter]



Refilling of compressor oil

- When you refill the separator receiver tank with compressor oil, stop the engine, and make sure that the pressure gauge indicates 0psi (0bar) and there is no residual pressure in it, and then gradually loosen the oil filler cap for refilling oil.
- Note residual pressure in the receiver tank could force both extremely hot compressed air and oil to jet out and you may be scalded or seriously injured.
- Even continuous oil replenishment cannot improve its deteriorated condition. Be sure to change the oil completely at every scheduled interval.
- Do not mix it with other brand oil, or it will cause poor performance and shorten the life of the compressor oil. (But fresh compressor oil could accept a mixture of small amount of different brands.)
- Running the unit with old and deteriorated compressor oil will cause damage to bearings, or serious accident like ignition in a separator receiver tank. Be sure to change the oil completely at every scheduled interval.
- Follow the designated regulations to dispose of compressor oil.



<Procedure>

- ① After residual pressure is completely relieved from separator receiver tank, remove oil filler cap “1” and open drain valve “2” for draining oil. And then open drain valve “4” of oil cooler for draining also the oil accumulated in bottom of oil cooler.
- ② After compressor oil is completely drained out, close drain valve “2” and “4” for sure.
- ③ After refilling fresh compressor oil up to the upper limit of level gauge, close oil filler cap “1”. Check o-ring “3” of oil filler cap “1” whether it is hardened and/or damaged. If it is found damaged or hardened, replace it with a new one.

[Quantity of oil : approx. 3.96gal.(15L)]

- ④ Start the engine for a short while, then replenish the oil to fill shortage. Repeat this procedure for 1 to 2 times to check if the oil level has reached its appropriate point. Be careful not to overfill the oil.
- If oil is cold when it is changed, it takes a longer time to drain oil completely. But make sure to drain oil completely.

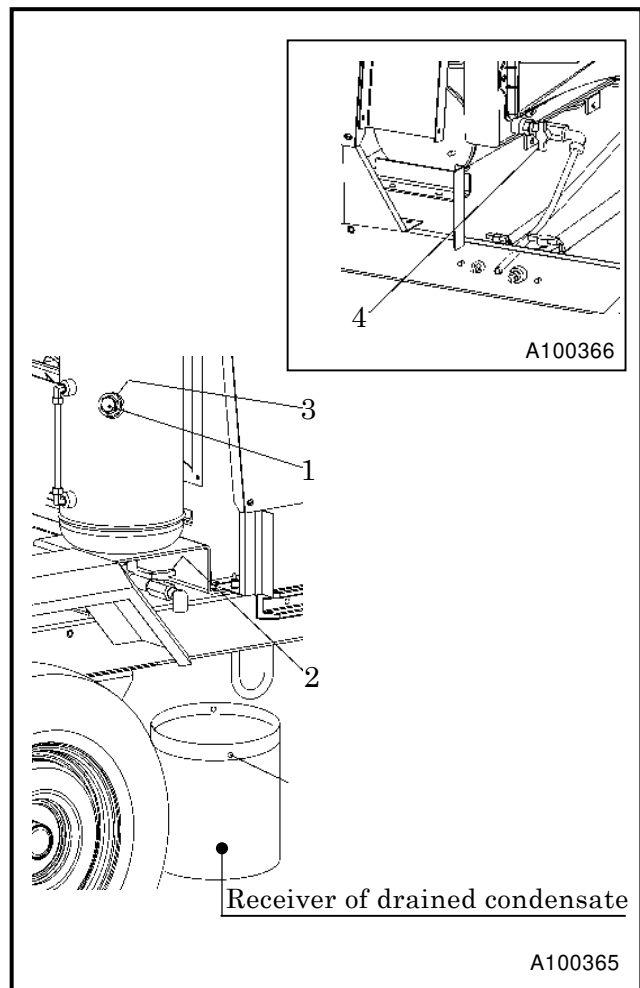

5.Periodic Inspection/Maintenance

5.5.6 Change compressor oil filter

[At 300 hours for the first change and every 1,000 hours thereafter]

IMPORTANT

Use our genuine oil filter

- Poor quality oil filters do not trap dust sufficiently and will cause damage to the bearings in a short period.

<Procedure>

- ① Remove the cartridge "1", using a filter wrench.
- ② Screw in the new cartridge "1" with the packing "2" coated slightly with oil. **(For part number, see 5.4)**
- ③ After the packing "2" touches the sealing face, further tighten it by turning it 3/4 time with the filter wrench.
- ④ After installing the oil filter, check it for any leak during operation.

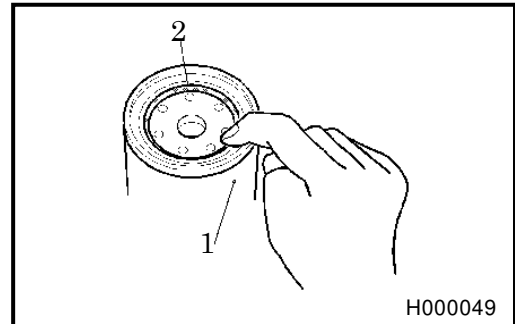

5.5.7 Clean strainer in the scavenging orifice [Every 500 hours]

<Procedure>

- ① Remove the pipe "1", using a spanner.
- ② First remove the bushing "2".
- ③ Then remove the strainer "3".
- ④ Wash the removed strainer "3" in diesel oil and blow out "dust" by air blowing.
- ⑤ After finishing the cleaning, install the strainer "3" again in the reverse procedure.

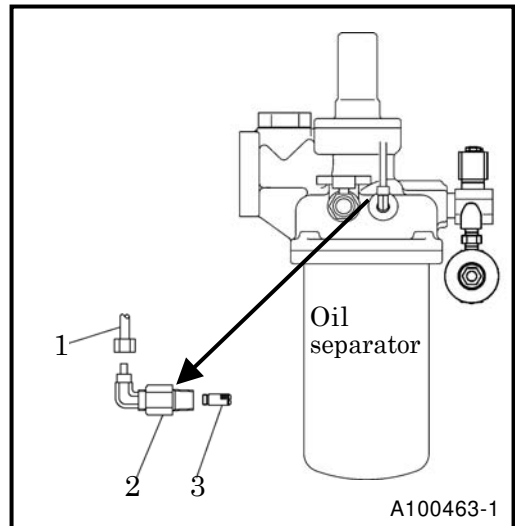

5.5.8 Change air filter element [Every 500 hours]

IMPORTANT

Use our genuine part

- Air filter is an important part which is crucial to machine's performance and life. Be sure to use genuine parts.

<Procedure>

- ① After removing the cap "1" by loosening its latch "2", clean its interior properly.
 - ② Remove the element "3" and then replace it with a new one. **(For part number, see 5.4)**
 - ③ When installing the cap "1" after finishing the replacing job, push the element into the case "4" surely by hand, and then make sure that the latch "2" fixing the cap surely hooks the case "4". Finally tighten it.
- When used or operated under bad conditions, it is better to remove all the elements, check them, clean them and replace them earlier before the intervals listed in maintenance table, if they are found difficult to be repaired.

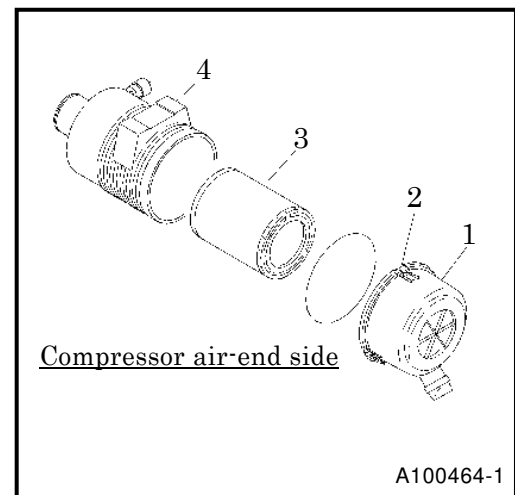

5.Periodic Inspection/Maintenance

5.5.9 Clean of element in sedimenter [Every 500 hours]

<Procedure>

- ① Turn fuel selector valve “1” to “OFF” position.
 - ② Loosen the drain valve “2” and drain out condensed water inside.
 - ③ Turn the cup “3” to the left and remove it.
Be careful to remove the cup “3” because it is filled with fuel. Wipe out split fuel completely.
 - ④ Remove float “4” inside cup “3” .
 - ⑤ Washing element “5” and the cup inside with new fuel.
 - ⑥ Replace element “5” and o-ring “6” , “7” if they are found broken or damaged. **(For part number, see 5.4)**
 - ⑦ After finishing clean, assemble it in reverse procedure.
- If air is found still in fuel pipe, place starter switch to “RUN” position and loosen air bleeding bolt “8” to bleed air. After finishing air bleeding, tighten the air bleeding bolt “8” .
 - Drain the condensate in container “9” ,and then dispose of condensate according to the designated regulations.

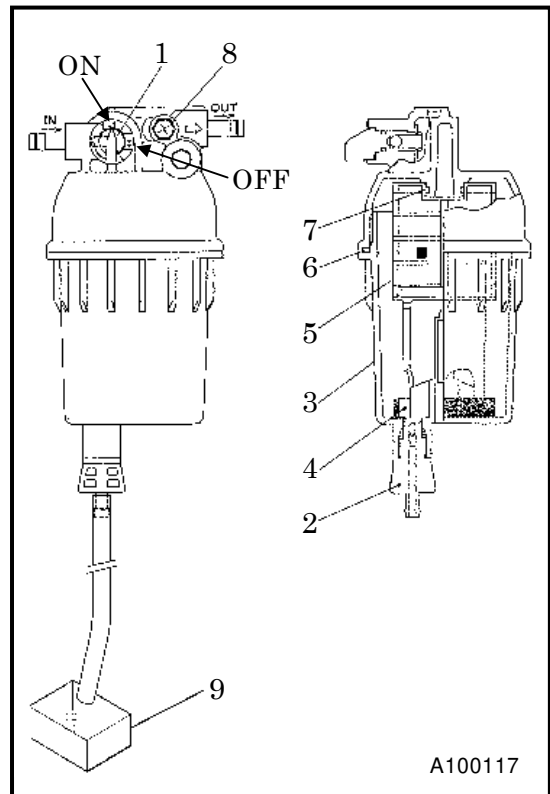

5.5.10 Change fuel filter [Every 500 hours]

<Procedure>

- ① Remove the fuel filter cartridge “1” , using a filter wrench.
- ② Install the new cartridge “1” after applying oil to the surface of gasket “2” of cartridge “1” .
(For part number, see 5.4)
- ③ Give 1 turn to the cartridge “1” by hand after the packing touches the sealing face.
- ④ After installing fuel filter cartridge “1” , check for fuel leak during operation.

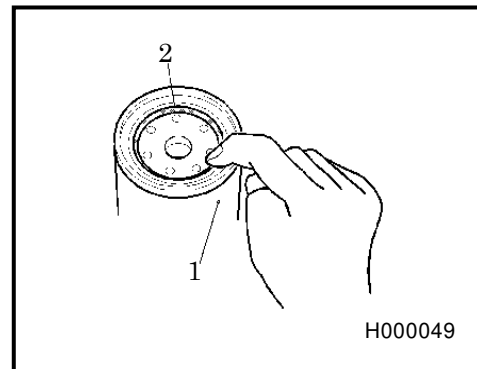

5.Periodic Inspection/Maintenance

5.5.11 Change diaphragm of speed regulator [Every 1,000 hours]

<Caution during diaphragm replacement>

- When installing diaphragm “1” , be sure to use the special jig to prevent it from twisting.
- Before installing diaphragm “1” , be sure to apply molybdenum disulfide (paste spray) to inside of the diaphragm “1” .
- Install it so that its outside surface should be rubber and its inside cloth.

(For part number, see 5.4)

- When replacing it, contact directly us or distributor because it requires expert technical knowledge.

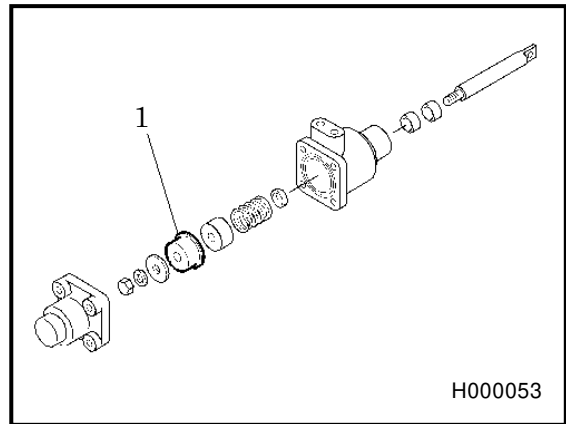

5.5.12 Clean outside of the radiator·oil cooler [Every 1,000 hours]

- When the fin tubes diaphragm “1” , of a radiator, and an oil cooler are clogged with dust or other foreign materials, the heat exchange efficiency drops and this will raise coolant temperature and discharge air temperature. These tubes and fins should be cleaned depending on the state of clogged tubes diaphragm “1” , even before maintenance schedule.
- Do not use a high pressure washer to protect fin tubes “1” from being damaged.

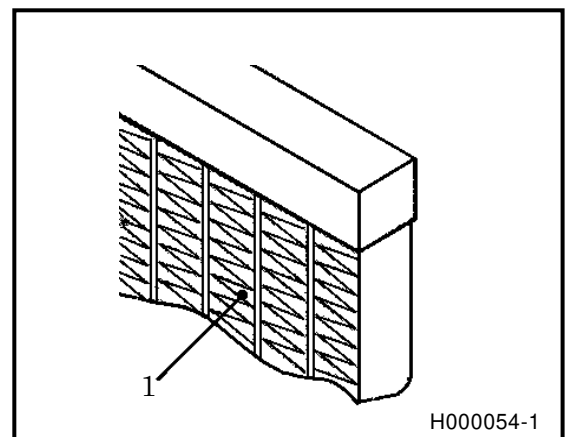

5.5.13 Clean inside of radiator [Every 1,000 hours]

- When the inside of a radiator and water conduits of an engine are dirty with scale and rust, its cooling efficiency will be deteriorated. Clean the interiors of such components periodically.
- When cleaning it, contact directly us or distributor because it requires expert technical knowledge.

5.Periodic Inspection/Maintenance

5.5.14 Supply grease to trailer hub bearing

[Every 1,000 hours]

- Call your nearest dealer for replenishing grease to the trailer hub bearing.

Grease: Chassis grease

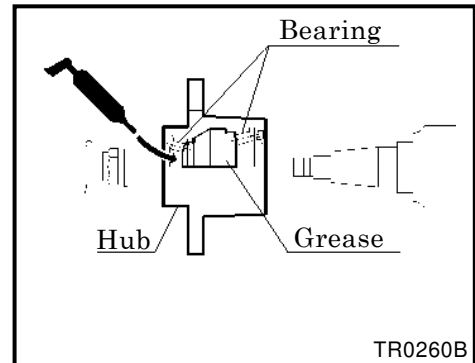

5.5.15 Supply grease to each part of trailer

[Every 1,000 hours]

- Supply grease through grease nipples positioned at the bottom.

Grease: Chassis grease

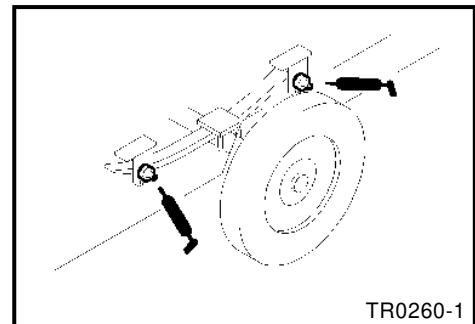

5.5.16 Change coolant

[1,000 hours or every 2 years]

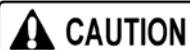

Caution in filling or discharging engine oil

- Be sure to stop the machine and allow time to cool. Then loosen the radiator cap one notch. After the coolant water is sufficiently cooled and the inner pressure is released, take the cap off. If this procedure is neglected, the inner pressure can blow off the cap. Steam jetting out of the radiator could result in causing scalding. Follow this procedure under all circumstances.

- LLC (Antifreeze) is a toxic material.
- When a person has drunk LLC (Antifreeze) by accident, make him vomit and see a doctor immediately.
- When a person gets LLC (Antifreeze) in his eyes, wash the eyes with clean running water and make him see a doctor immediately.
- When LLC (Antifreeze) is stored, put it in a container with an indication saying "LLC (Antifreeze) inside" and seal it up, then keep it in a place away from children. Beware of flames.

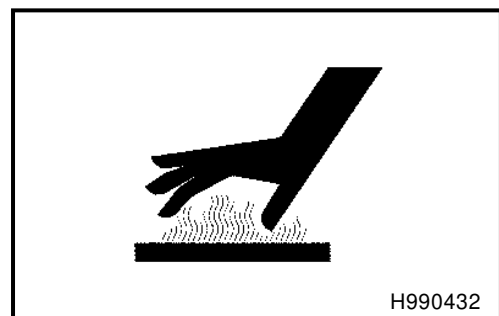

5.Periodic Inspection/Maintenance

<Procedure>

- ① To drain coolant, remove the radiator cap “1” Remove out side radiator drain plug “2” and open drain valve “3” for drainage.
- ② Loosen the drain plug “4” provided on engine to drain engine.
- ③ After drainage is finished, tighten drain plug “2” , “4” and then close radiator drain valve “3”.
[Quantity of water : approx. 1.5 gal.(5.8L)]
- ④ After changing the coolant, operate the machine for 2 to 3 minutes at the unloaded condition and stop it. Then check the coolant level again, and replenish if it is short.

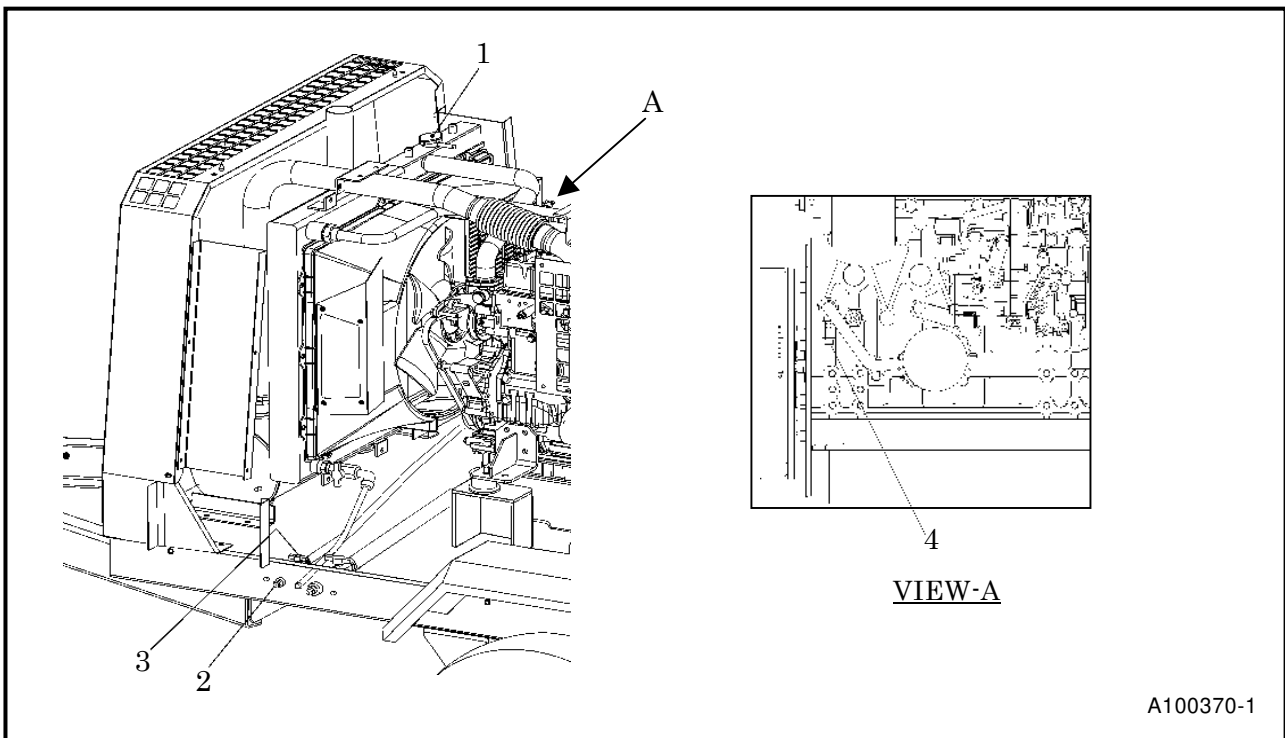

5.5.17 Change nylon tubes [2,000 hours or every 2 years]

- Replace nylon tubes used for the oil and air pipings.
- When replacing it, contact directly us or distributor because it requires expert technical knowledge.

5.5.18 Change fuel hose [2,000 hours or every 2 years]

- In case various rubber hoses for fuel system and engine lubrication system are hardened or deteriorated, replace them even before the specified replacement time.
- When replacing hoses, contact directly us or distributor because it requires expert technical knowledge.

5.Periodic Inspection/Maintenance

5.5.19 Change oil separator [Every 2,000 hours]

IMPORTANT

- When changing the oil separator, both cover and element must be replaced with new ones.
- Even before the periodic interval time of replacement, replace the oil separator whenever the oil consumption increases and also oil is found mixed in the discharge air.
- When consumption of the oil is still unusual even after cleaning strainer in the scavenging orifice (See 5.5.7), change the oil separator with a new one.
(For Replacement parts, See 5.4)
- When replacing oil separator, contact directly us or distributor because it requires expert technical knowledge.

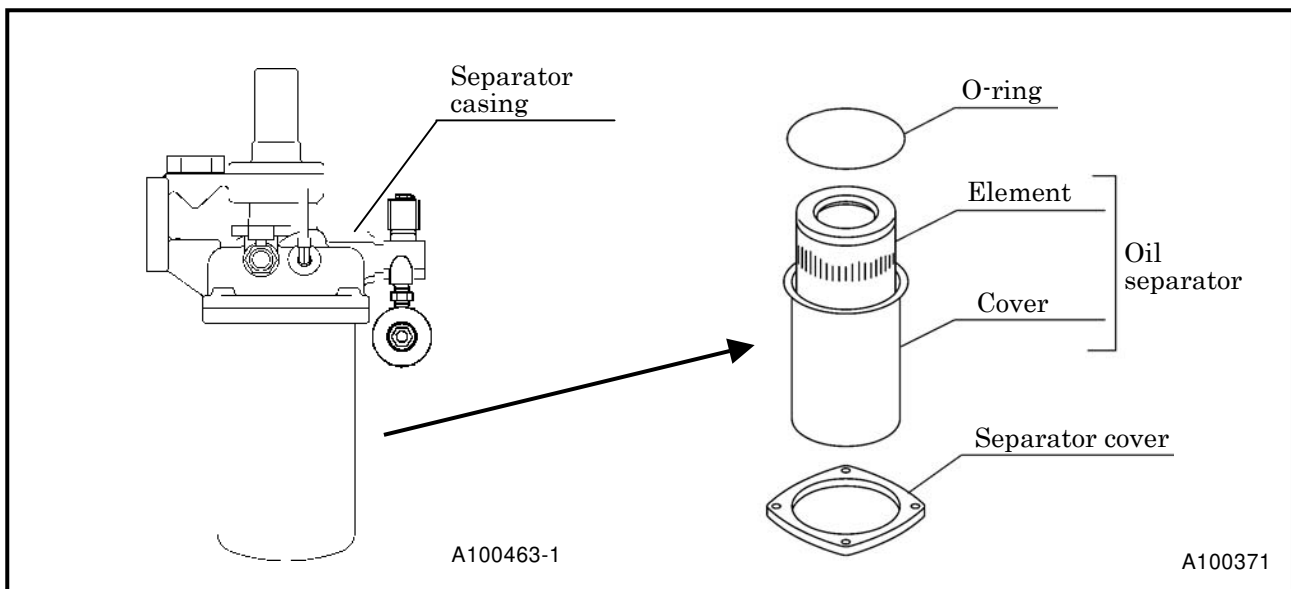

5.5.20 Change pressure regulator [Every 3,000 hours]

- Remove pressure regulator and rebuild or replace with a new unit. (For part number, see 5.4)

5.Periodic Inspection/Maintenance

5.5.21 Change o-ring of unloader [3,000 hours or every 3 years]

<Caution during O-ring replacement>

Supply grease to O-ring "1", "2", "3", "4" after replacement.

(For part number, see 5.4)

Grease: CALTEX MULTIFAX EP1

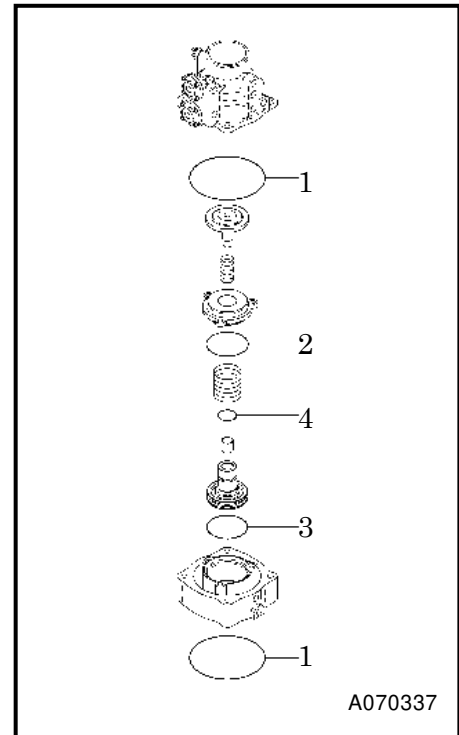

5.5.22 Check rubber hose [3,000 hours or every 3 years]

- Check hoses used for oil piping for any crack or tear, and replace when an abnormality is found.
- When replacing hoses, contact directly us or distributor because it requires expert technical knowledge.

5.5.23 Change radiator hoses [3,000 hours or every 3 years]

- When any crack or wear is found on the hoses, change it even before the scheduled time.
- When replacing it, contact directly us or distributor because it requires expert technical knowledge.

5.Periodic Inspection/Maintenance

5.5.24 Check o-ring and needle valve of auto-relief valve and vacuum relief valve [3,000 hours or every 3 years]

- Disassemble and clean the component, and check O-ring “1”, “2”, “3” and needle valve “4”. Then, replace O-ring “1”, “2”, “3” and rubber on the needle valve “4”, if hardened.

(For part number, see 5.4)

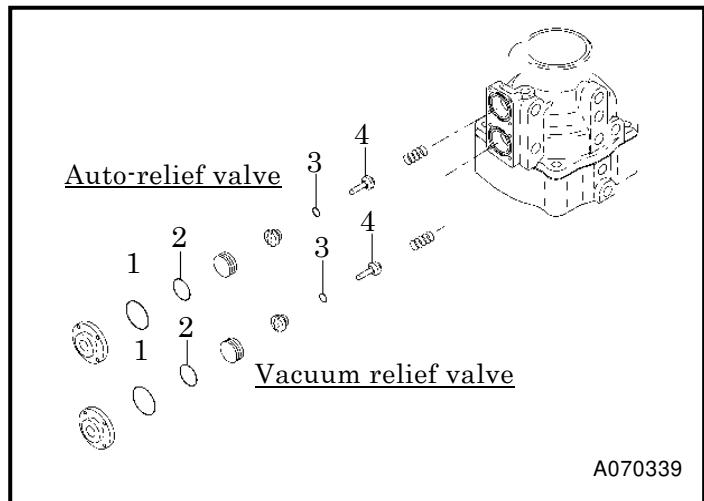

5.5.25 Performance check of pressure control valve [3,000 hours or every 3 years]

IMPORTANT

- When reassembling, apply sufficient grease to O-ring Slot/O-ring and sliding surface. Use CALTEX MULTIFAK EP1 grease or equivalent. Grease of poor quality will deteriorate the material.

<Procedure>

- ① When closing stop valve and fully opening service valve while the machine is running, make sure that the discharge pressure gauge shows the figure between 49 to 68psi(3.4 to 4.7 bar).
- ② When the pressure is lower than 49psi(3.4 bar), replace spring “3” with a new one. (For part number, see 5.4)
- ③ When the indicator shows excessively higher pressure, you will find that the piston does not move smoothly due to foreign material and rust stuck inside valve. In such a case, disassemble the component for checking and cleaning.

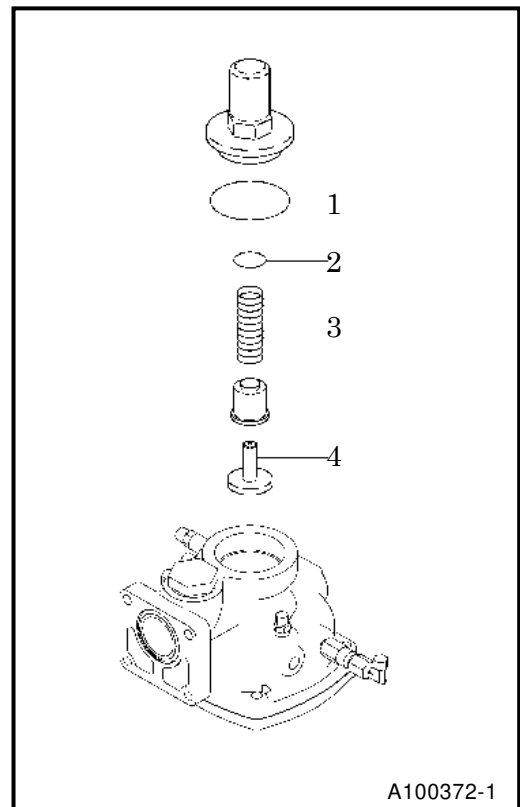

5.Periodic Inspection/Maintenance

5.5.26 Check o-ring and piston of pressure control valve

- After disassembling and cleaning pressure control valve, check O ring “1” , “2” and piston “4” .
When the rubber of these parts is found hardened, or damaged, replace them.
(For part number, see 5.4)
- When replacing it, contact directly us or distributor because it requires expert technical knowledge.
- After replacement, run the machine to check its function (**See 5.5.26**), air-leak or any disorder.

5.5.27 Check and confirm that drawbar is properly fixed with bolts properly, according to specified tightening torque. [Every 3 months]

- Check and confirm once every three months that the bolts with which drawbar is fixed are not loosened. (8 points)
- If it is found that specified tightening torque of clamped bolts drops to a lesser value, retighten them to correct specified value.

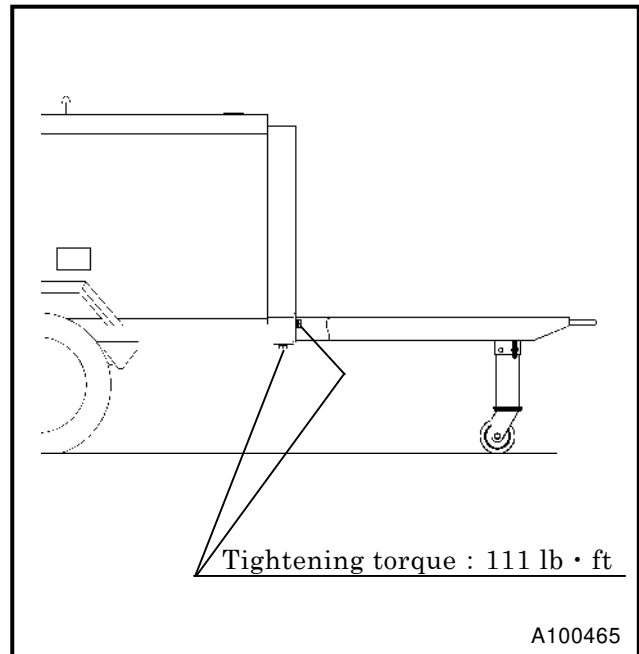

5.5.28 Check and confirm that the bolts with which undercarriage brackets are fixed are properly tightened. [Every 3 months]

- Check and confirm once every three months that there is no looseness in tightening bolts. (8 points)
- If it is found that specified tightening torque of clamped bolts drops to a lesser value, retighten them to correct specified value.

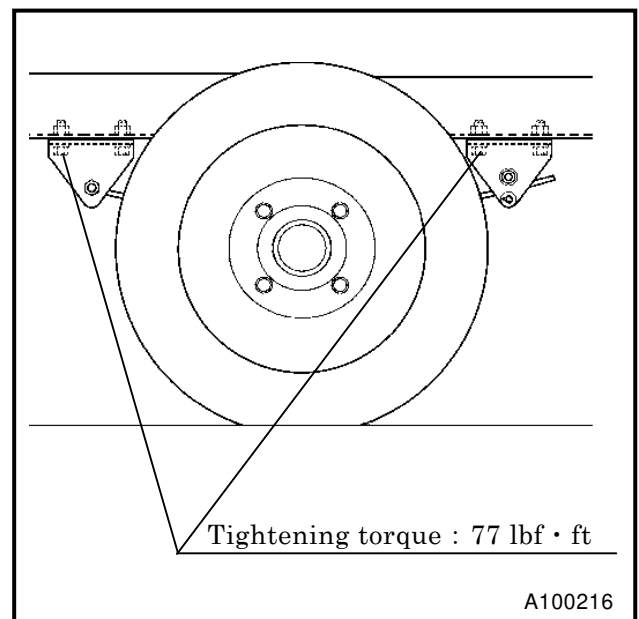

5.Periodic Inspection/Maintenance

5.5.29 Check and confirm that the nuts with which tires are fixed are properly tightened.

[Every 3 months]

- Check and confirm once every three months that hub nuts with which tires are fixed are not loosened. (8 points)
- If it is found that specified tightening torque of clamped bolts drops to a lesser value, retighten them to correct specified value.

[Standard pressure for a tire is at 65psi(4.5bar)]

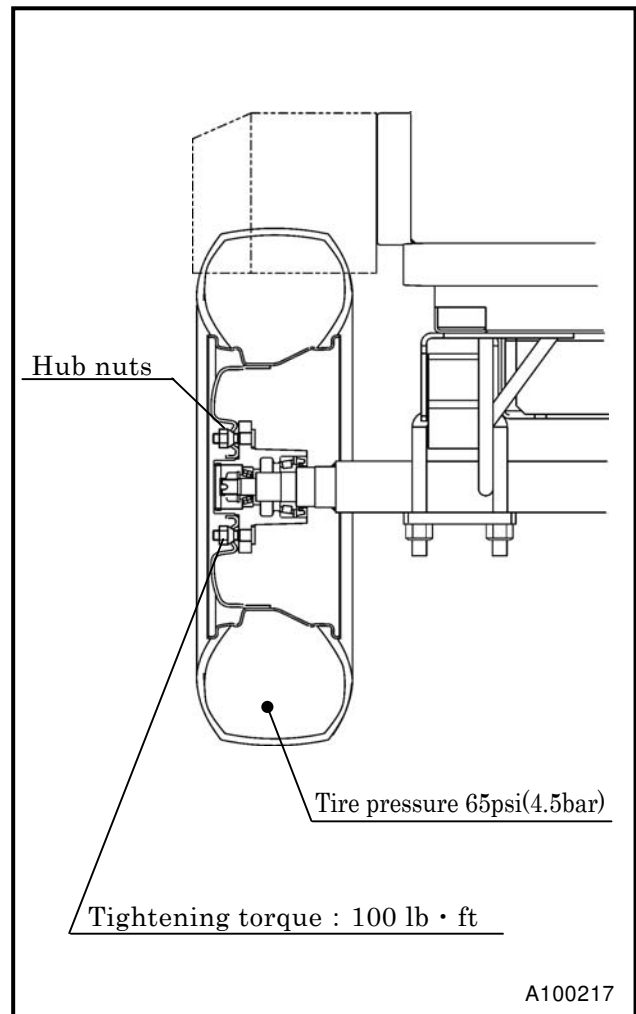

6. Maintenance

6.1 Maintenance of Battery



- Keep flames away from battery.
- Battery may generate hydrogen gas and may explode.
- Therefore, recharging should be done at a well-ventilated place.
- Do not spark near the battery nor light a match, nor bring lit cigarette and match close to the battery.
- Do not check the battery by short-circuiting the positive and negative terminals with a metallic piece.
- Never operate the machine nor charge the batteries with the battery liquid level being kept lower than the "LOWER" level. Continuing operation at this lower level will cause deterioration of such parts as pole plates etc., and also it may cause explosion as well as reduction of battery life. Add distilled water so that the liquid level may reach the middle level between the "UPPER" and "LOWER" level without any delay.
- Do not charge the frozen battery. Otherwise it may explode. If the battery is frozen, warm it up until the battery temperature becomes 61°F to 86°F.
- Battery electrolyte is dilute sulfuric acid. In case of mishandling, it could cause skin burning.
- When you deal with a battery, please be sure to wear protection implements, such as protection glasses and a glove.
- When such battery electrolyte contacts your clothes or skin, wash it away with large amount of water immediately.
- If the battery electrolyte gets into your eyes, wash it away immediately with plenty of water and see a doctor at once, because it is feared that eyesight might be lost.
- Dispose of battery, observing local regulations.

Handling battery



D004

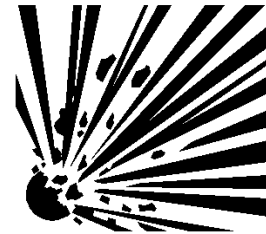

W010



TR0093

6. Maintenance

6.1.1 Charge battery

- Be sure to read the operation manual of the battery charger to know if it is applicable, before using it.
- Disconnect the cable between battery and the unit, and charge the battery with a 12V battery charger. Do not charge two batteries at the same time.
- Be sure not to connect (+) and (-) terminals backwards.

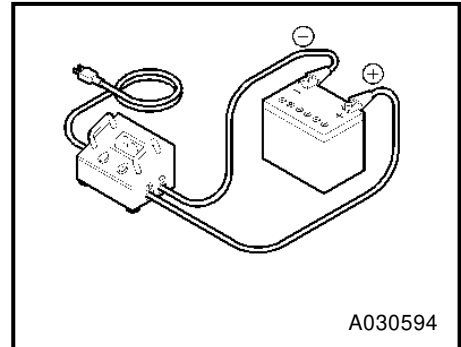

6.1.2 How to use booster cable

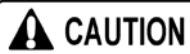

Do not reverse the cable connection

- If a booster cable has to be used or when cables are connected at battery replacement, be careful not to connect (+) and (-) terminals backwards. Such a wrong-connection will cause spark and damage each component.

<Procedure for using a booster cable>

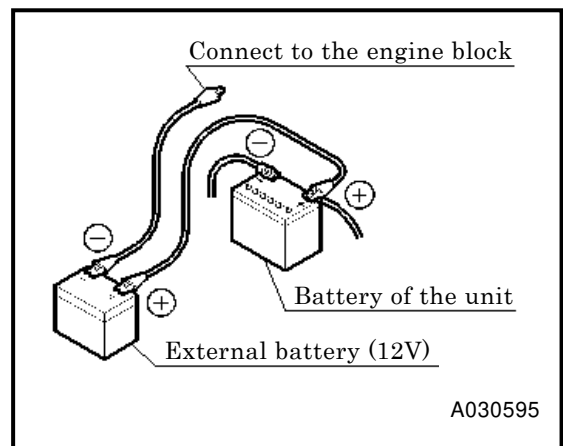

- ① Stop the engine.
- ② Connect one end of the (+) cable to the (+) terminal of the machine battery.
- ③ Connect the other end of the (+) cable to the (+) terminal of the external battery.
- ④ Connect one end of the (-) cable to the (-) terminal of the external battery.
- ⑤ Connect the other end of the (-) cable to the engine block of the machine.
- ⑥ Start up the engine.
- ⑦ Disconnect the booster cable by following the procedure back in the reverse order.



6. Maintenance

6.2 Indicator lamp and Warning / Emergency display

[Indicator lamp] Turn the starter switch to “RUN” position. Then the lamp goes on.

Item	Contents	Measures	Monitor
GLOW	Press starter switch “GLOW” and the lamp goes on and after preheating is finished, the lamp will be off.	—	
CHARGE	Lamp goes on when alternator is not charging.	Check wiring. Check alternator.	

[Warning Display] Whenever a little disorder or trouble occurs during operation, the operation continues. When the warning lamp flickers, take appropriate measures to recover the situation swiftly.

Item	Failure code	Contents	Measures
DISCHARGE TEMP.H	A1	Lamp flickers when the air temperature at the outlet of the air-end reaches 239°F (115°C).	See “Troubleshooting”
WATER TEMP.H	A2	Lamp flickers when coolant temperature reaches 221°F (105°C).	
CHARGE	A5	Fan belt loosened and/or cut Faulty generation of alternator	See “Troubleshooting”

[Emergency Display] When abnormality occurs during operation, it displays, lamp lights and the machine is brought to emergency stop. Be sure to follow the measures shown below before starting the unit again.

Item	Failure code	Contents	Measures
DISCHARGE TEMP. H	E1	Lamp displays when the air temperature at the outlet of the air-end reaches 248°F (120°C).	See “Troubleshooting”
WATER TEMP.H	E2	Lamp displays when coolant temperature reaches 230°F (110°C).	
ENG. OIL PRESS.	E3	Lamp goes on when engine oil pressure drops. [The function pressure is below 7.3psi(0.5bar).]	
DISCHARGE TEMP.SENSOR	E6	It is displayed when air temperature sensor at the outlet port of compressor air end is disconnected.	
WATER TEMP.SENSOR	E7	It is displayed when engine coolant temperature sensor is disconnected.	

6. Maintenance

6.3 Troubleshooting

- Should any trouble occur during operation, do not leave it. Investigate the cause and take appropriate measures.
- Read the manual carefully and fully understand what to do in case of trouble.
- The better you understand the construction and function of the unit, the faster you can find a problem and solution.
- This chapter describes the state, cause and countermeasures of important troubles in detail:

Symptom	Cause	Countermeasures
Low starter revolution speed.	(1) Battery malfunction.	Check battery→ Charge, change
Starter rotates but engine does not start.	(1) Fuel filter clogging. (2) Malfunction of fuel stop solenoid. (3) No fuel.	Disassemble, clean, and change Check fuse Change solenoid Check connector Replenish fuel
Discharge air pressure does not reach 100psi(6.9bar).	(1) Pressure regulator insufficient adjustment. (2) Pressure regulator trouble.	Re-adjust (fasten) Change
Engine does not reach its maximum speed.	(1) Improper length in speed regulator rod. (2) Unloader orifice clogging. (3) Malfunction speed regulator. (4) Engine trouble. (5) Fuel filter clogging. (6) Water is accumulated in sedimenter. (7) Air filter element clogging.	Re-adjust Disassemble/Clean Disassemble/Check Call your nearest dealer Disassemble/Change Drain water Clean or change of element
Revolution drops before discharge air pressure reaches 100psi(6.9bar).	(1) Pressure regulator insufficient adjustment. (2) Trouble of pressure regulator. (3) Unloader orifice clogging.	Re-adjust (fasten) Change Disassemble/Check
Engine does not reach minimum revolution at unload.	(1) Improper length in speed regulator rod. (2) Malfunction speed regulator.	Re-adjust Disassemble/Check
Safety valve relieves at unload.	(1) Pressure regulator insufficient adjustment. (2) Speed regulator diaphragm damaged. (3) Unloader valve damaged· Faulty seat (4) Faulty safety valve. (5) Improper length of speed regulator rod	Re-adjust (loosen) Change Change Change Re-adjust (elongate)
Oil mixes in air. (poor oil separation)	(1) Scavenging orifice strainer clogging. (2) Excessive oil in receiver tank. (3) Low discharge pressure. (4) Oil separator deteriorated.	Disassemble/Clean Drain to its proper level Disassemble and check of pressure control valve Check /Change
Insufficient free air delivery.	(1) Air filter element clogging. (2) Unloader valve cannot fully open. (3) Engine does not reach rated speed.	Clean or change of element Call your nearest dealer Call your nearest dealer

6. Maintenance

Symptom	Cause	Countermeasures
It is indicated that engine oil pressure is abnormal, and engine stops.	(1) Engine oil shortage. (2) Engine oil filter clogging. (3) Faulty oil pressure switch. (4) Loosened or disconnected wiring or connector.	Replenish oil Change Change Check/Fasten
It is indicated that coolant temperature is abnormal, and engine stops.	(1) Radiator clogging. (2) Faulty thermostat. (3) Faulty coolant temp. switch. (4) Low coolant level. (5) Fan belt slippage. (6) Loose wiring, connectors and disconnection. (7) Coolant temp. sensor is disconnected.	Clean Change Change Replenish Re-adjust tension Check/retighten Repair and replace
It is indicated that discharge air temperature is abnormal, and engine stops.	(1) Oil cooler clogging. (2) Oil filter clogging. (3) Faulty discharged air temp. switch. (4) Loose wiring connectors and disconnection. (5) Slippage of fan belt. (6) Shortage of compressor oil. (7) Discharge air temp. sensor is disconnected.	Clean Change Disassemble/Check Check/retighten Re-adjust tension Replenish oil Repair and replace

- Contact your nearest dealer if you find it difficult to repair by yourselves.
- Refer to the engine operation manual for trouble concerning the engine.

6.4 Adjustment of Various data

- The following set values can be altered and adjusted.

No.	Item	Indication	Unit	Primary set value	Pange of set values
1	Purge releasing pressure	L	PSI	86	70~100
2	Waiting time for transfer to purge mode operation	T	Second	10	5~60
3	Load factor for transfer to purge mode operation	b	%	15	5~30

<Procedures of adjustment>

When auto-idle switch is pressed longer (than 5 second), first L. (Purge releasing pressure) is displayed. Each time auto-idle switch is pressed, each indication will be selected. Then each time it is pressed one time, T. (Waiting time for transfer to purge mode operation) is switched to b. (Load factor for transfer to purge mode operation), according to the set orders.

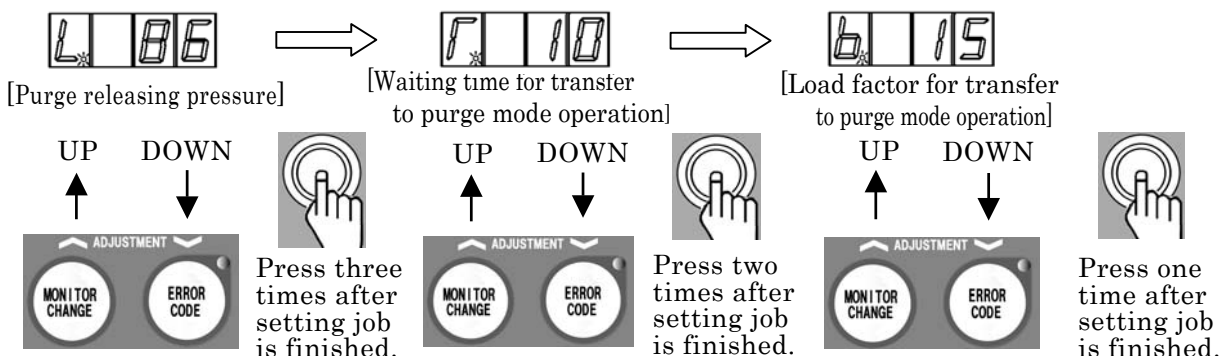

7. Storage of the Unit

7.1 Preparation for Long-term Storage

When the unit is left unused or not operated longer than half a year (6 months), store it at the dry place where no dust exists after the following treatments have been done to it.

- Put the unit in a temporary cabin if it is stored outside. Avoid leaving the unit outside with a sheet cover directly on the paint for a long time, or this will cause rust to the unit.
- Perform the following treatments at least once every three months.

<Procedure>

- ① Drain existing lubricant from the engine oil pan. Pour new lubricant in the engine to clean its inside. After running it for a while, drain it again.
- ② Spread lubricant on moving parts like speed regulator and rod end, beforehand.
- ③ Completely charge the battery and disconnect grounding wires. Remove the battery from the unit, if possible, and store it in a dry place. (Charge the battery at least once every month.)
- ④ Drain coolant and fuel from the unit.
- ⑤ Seal the engine, air-intake port and other openings like the muffler with a vinyl sheet, packing tape, etc., to prevent moisture and dust from getting in the unit.
- ⑥ Be sure to repair any trouble and maintain the unit so that it will be ready for the next operation.

8. Specifications

8.1 Specifications

Model			PDS185S-6C2	
Compressor	Type		Single-stage oil cooled, screw type compressor	
	Free air delivery	cfm (m ³ /min)	185 (5.2)	
	Working pressure	psi (bar)	100 (6.9)	
	Lubricating system		Forced Lubrication by compressed pressure	
	Driving system		Direct driving with gear coupling	
	Receiver tank capacity	cu in. (m ³)	1,221 (0.020)	
	Lubricating oil capacity	gal. (L)	3.96 (15)	
Engine	Model		YANMAR 4TNV88-BDHKS	
	Type		Water-cooled 4-cycle direct injection	
	Number of cylinders, bore stroke		4-3.46in. × 3.54in. (4- 88mm × 90 mm)	
	Total displacement		cu in. (L)	133.6 (2.189)
	Rated output	GROSS	kW/min ⁻¹	36.4 / 3,000
		NET		34.9/ 3,000
	Lubricating oil capacity		gal.(L)	2.0(7.4) (The amount of initial filling)
				Approx. 2.0(7.4) (The amount of exchange)
	Coolant capacity (including radiator)		gal. (L)	1.5 (5.8)
	Battery			80D26RMF (12V)
Fuel tank capacity		gal. (L)	24 (90)	
General Specifications	Overall length		in. (mm)	128.7 (3,270)
	Overall length (Bonnet only)		in. (mm)	74.6 (1,895)
	Overall width		in. (mm)	66.9 (1,700)
	Overall height		in. (mm)	59.8 (1,520)
	Net dry mass		lb (kg)	1,962 (890)
	Operating mass		lb (kg)	2,183 (990)

8. Specifications

8.2 Outline drawing

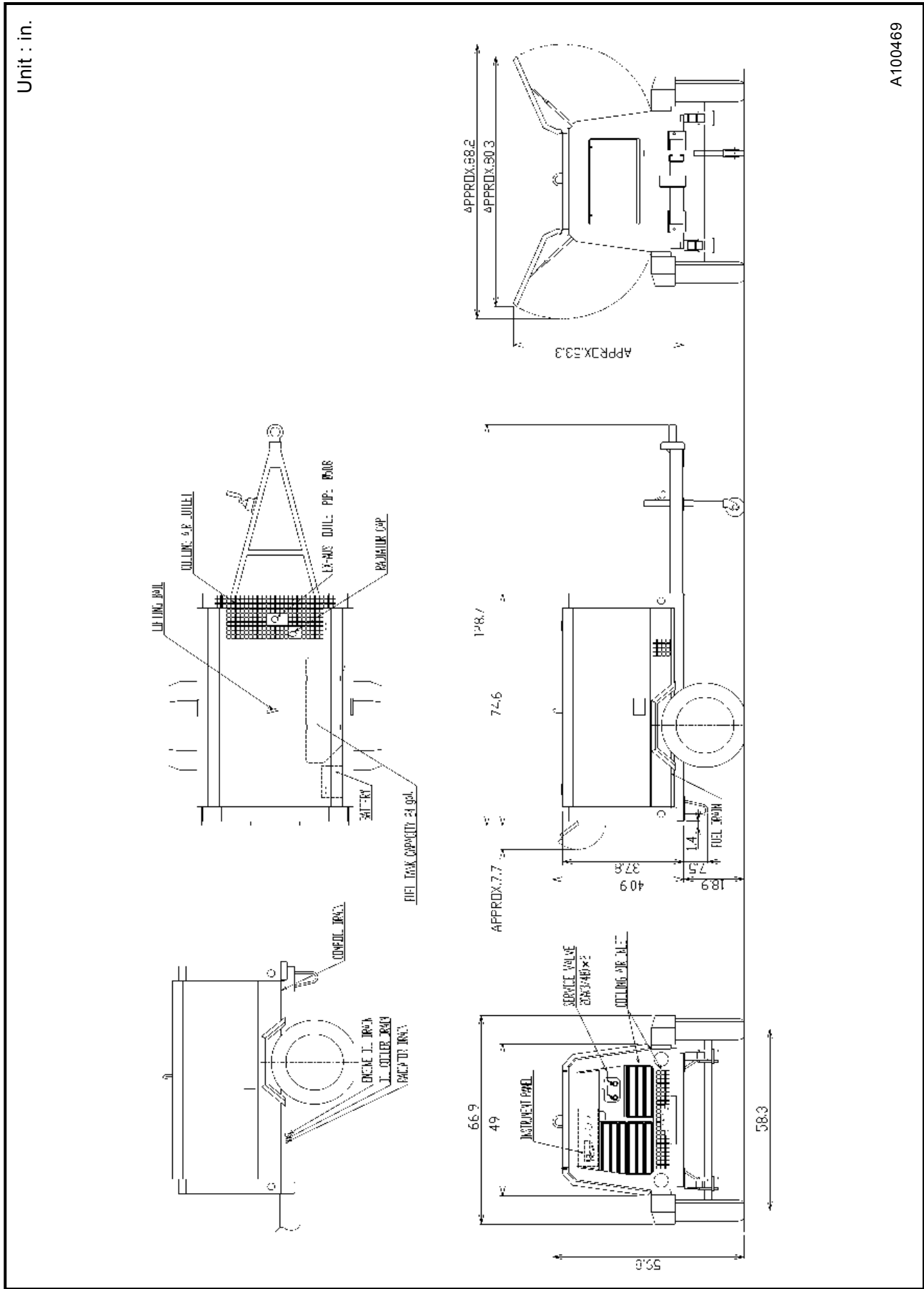

A100469

8. Specifications

Unit : mm

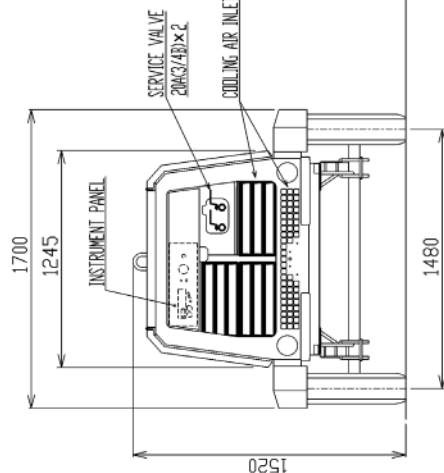
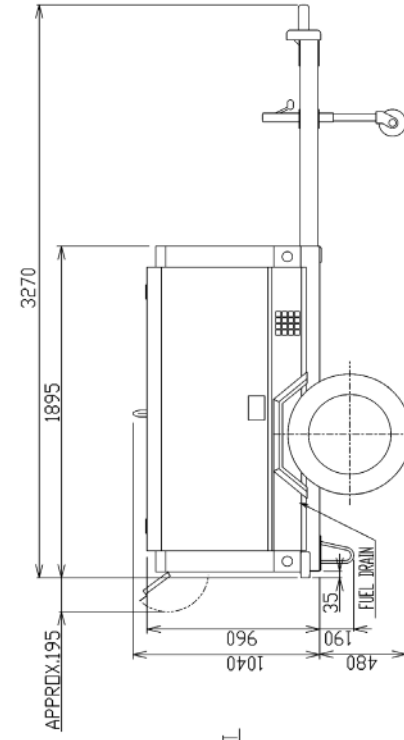
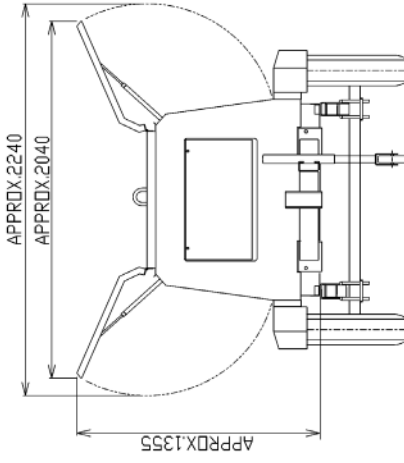
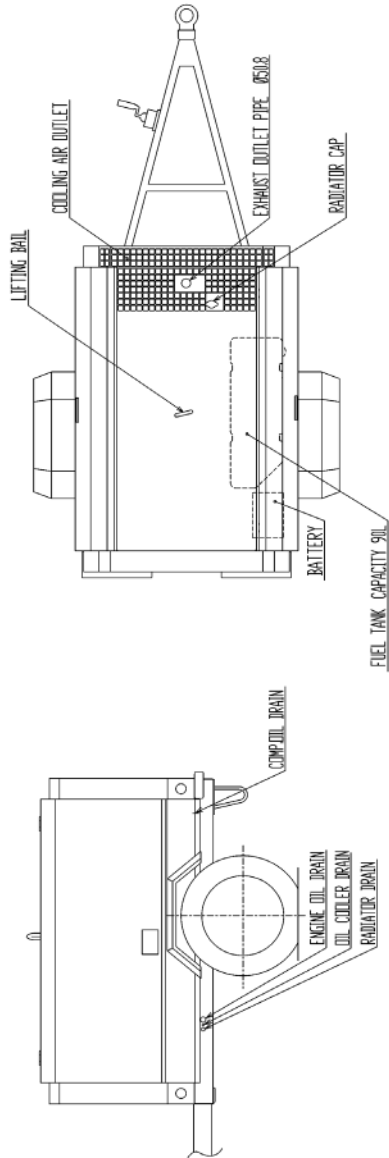

A100468

9. Wiring Diagram

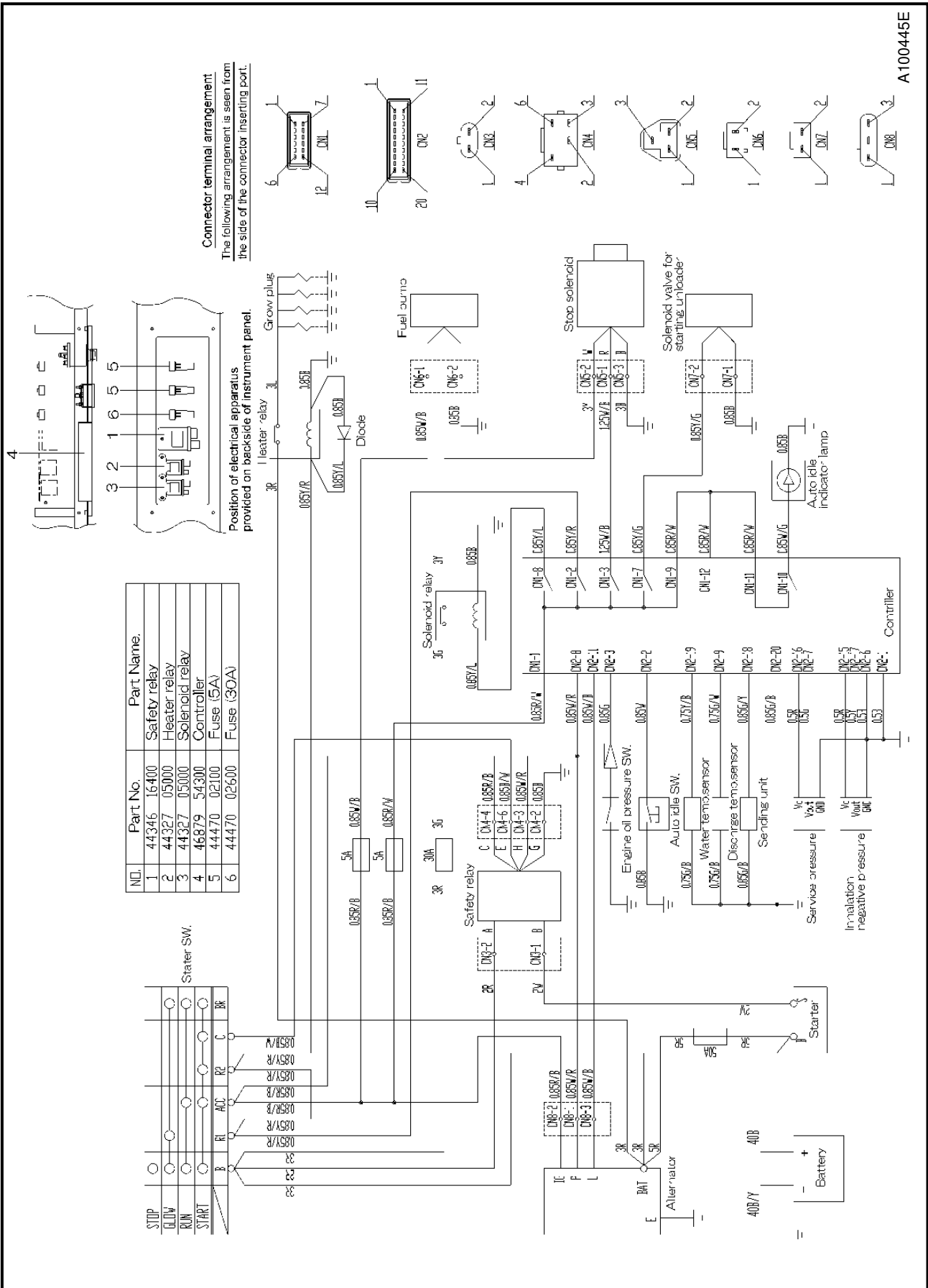

A100445E

10.Piping Diagram

10.1 Air piping · Compressor oil piping

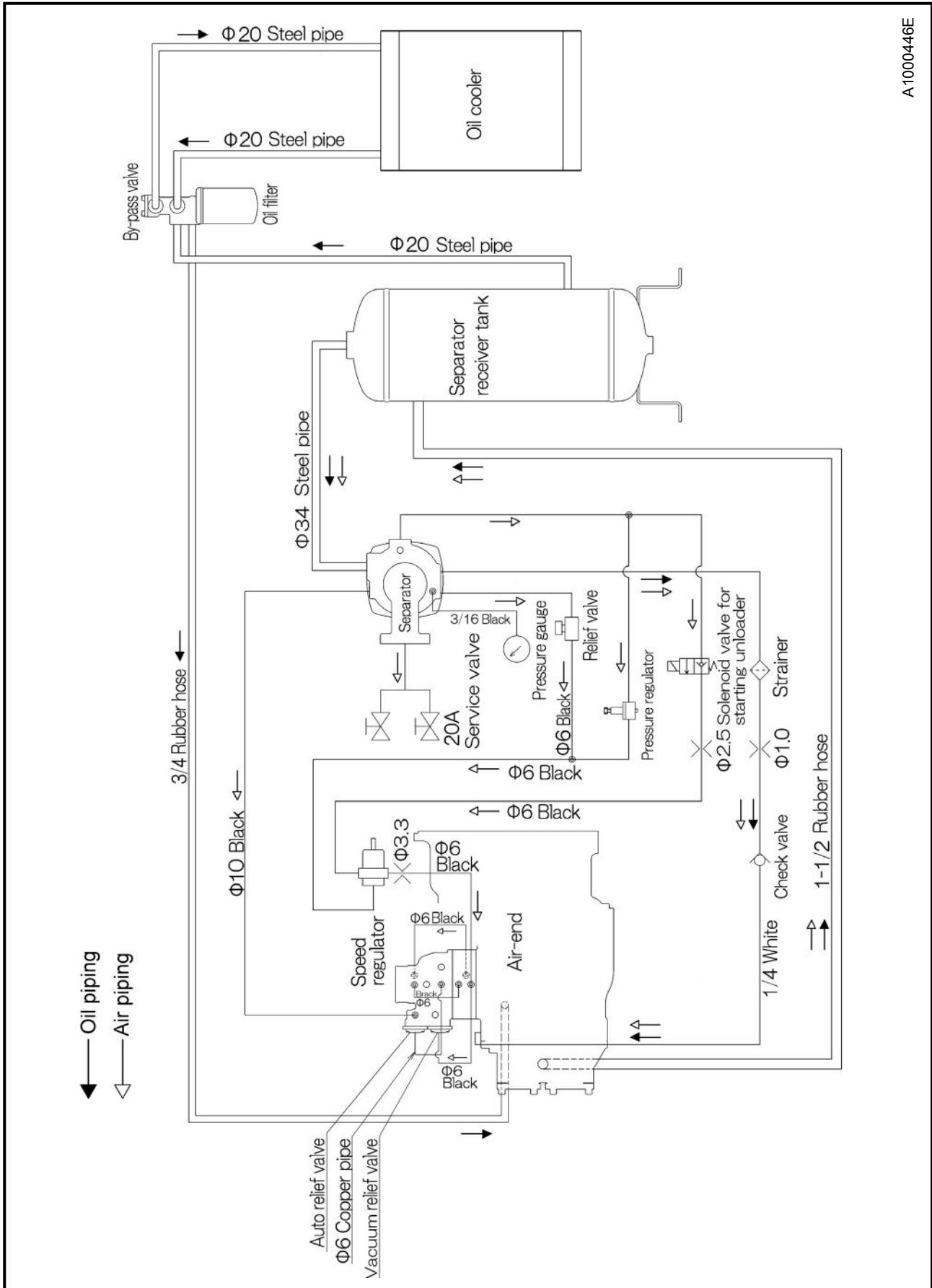

A1000446E

10.Piping Diagram

10.2 Fuel piping

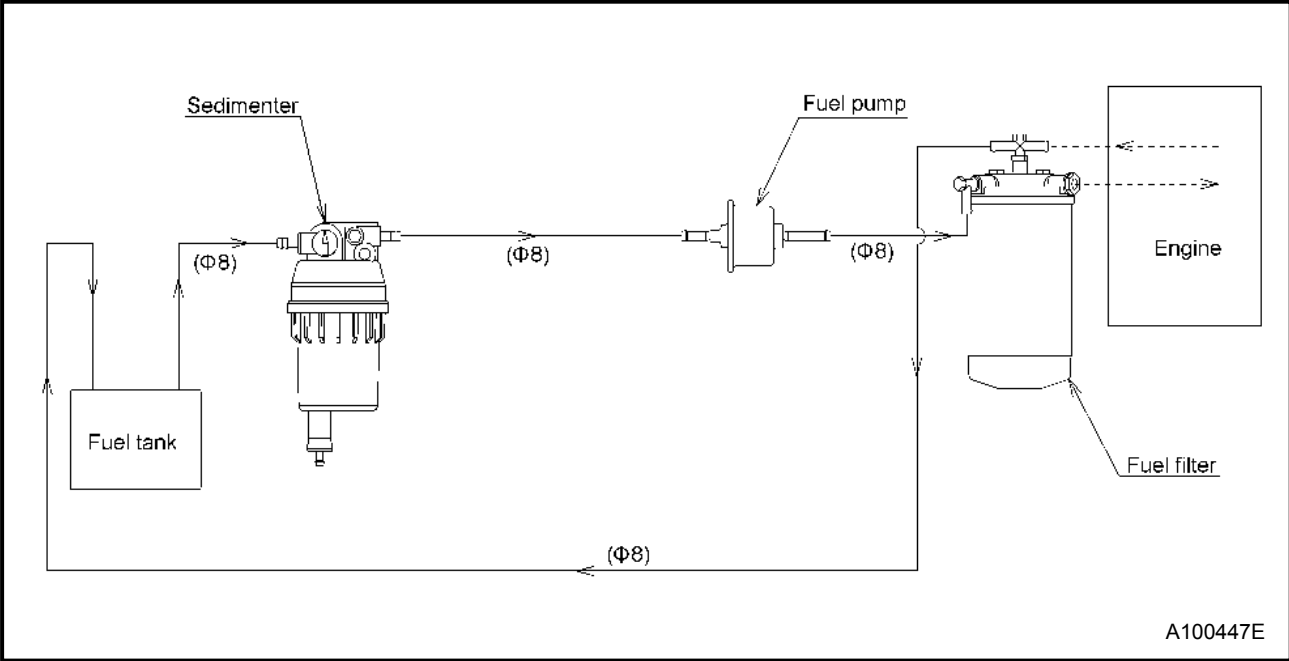

HOKUETSU INDUSTRIES CO., LTD.

8TH FLOOR SHINJUKU SAN-EI BLDG,
22-2 NISHI-SHINJUKU 1-CHOME, SHINJUKU-KU
TOKYO 160-0023 JAPAN
TEL:81-3-3348-7281
FAX:81-3-3348-7289
URL:<http://www.airman.co.jp>

Copyright(C)2010 HOKUETSU INDUSTRIES CO., LTD. All Rights Reserved

39600 15130
PRINTED IN JAPAN 2011.1



AIRMAN
HOKUETSU INDUSTRIES CO., LTD.