

AIRMAN

SG

INSTRUCTION MANUAL

ENGINE GENERATOR

SDG45S-8B1

SDG65S-8B1

[ENVIRONMENTAL CONTAINMENT
BASE TANK TYPE]

Please be sure to read this manual
before using this machine.

HOKUETSU INDUSTRIES CO., LTD.

Preface

Thank you for having selected our “AIRMAN” product.

- ◆ This manual explains about the proper operation and daily inspection and maintenance of this machine.
- ◆ In order to use a machine safely, people with sufficient knowledge and sufficient technology need to deal with it.
- ◆ Before operating the unit, read the manual carefully, fully understand its operation and maintenance requirement. Maintain “SAFETY OPERATION AND PROPER MAINTENANCE OF THE UNIT”.

Be sure to follow safety warnings and cautions given in the manual.
Unsafe operation could cause serious injury or death.

- ◆ For details of handling, maintenance and safety of the engine, see the Engine Operation Manual.
- ◆ Keep the manual available at all times for the operator or safety supervisor.
- ◆ If the manual is lost or damaged, place an order with your dealer for another copy.
- ◆ Be sure that the manual is included with the unit when it is handed over to another user.
- ◆ There may be some inconsistency in detail between the manual and the actual machine due to improvements of the machine. Ask your dealer if you have any questions or problems.
- ◆ If you have any questions about the unit, please inform us the model and serial number. A plate stamped with the model and serial number is attached to side of the unit.

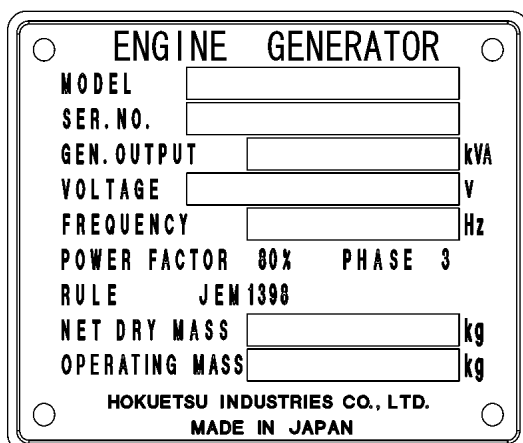

- ◆ Each illustrated figure (Fig.) has a number of 7 digits (for instance, A040491) at the right bottom. This number is not a part number, but it is used only for our reference number.

A040491





Table of Contents

1. Safety	1-1
1.1 Caution before Operation	1-2
1.2 Caution during Operation	1-4
1.3 Caution during Inspection and Maintenance	1-6
1.4 Safety Warning Labels	1-8
2. Part Names	2-1
2.1 Internal Components	2-1
3. Installation	3-1
3.1 Transporting Unit	3-1
3.2 Conditions of Unit Installation	3-2
3.3 Grounding Method	3-5
3.4 Selecting Cable	3-8
3.5 Selector Valve of Fuel Pipe	3-9
4. Operation	4-1
4.1 Instrument panel	4-1
4.2 Protection device	4-2
4.3 Connecting load	4-5
4.4 Engine Oil•Coolant•Fuel	4-8
4.5 Check before Starting the Machine.....	4-10
4.6 Unit Operation	4-13
4.7 Stopping Procedures.....	4-16
4.8 Emergency Stop	4-17
4.9 Air Bleeding.....	4-17
5. Periodic Inspection/Maintenance	5-1
5.1 Important items as Periodic and Maintenance or after Maintenance	5-1
5.2 Daily Inspection and keeping Operation Log	5-2
5.3 Periodic Replacement of Parts	5-3
5.4 Periodic Inspection List	5-4
5.5 Maintenance	5-5
6. Maintenance/Adjustment	6-1
6.1 Maintenance of Battery	6-1
6.2 Troubleshooting	6-3
7. Storage of the Unit	7-1
7.1 Preparation for Long-term Storage	7-1
8. Specifications	8-1
8.1 Specifications.....	8-1
8.2 Outline drawing	8-3
9. Wiring Diagram	9-1
9.1 Generator Wiring Diagram	9-1
9.2 Engine Wiring Diagram	9-2

1.Safety

This manual explains and illustrates general requirements for safety and cautions for safety.

Please read these safety requirements carefully and fully understand the contents before starting the machine.

For your better recognition, according to the degree of potential danger harmful to a human body, safety messages are classified into three hierarchical categories, namely, , , and  with a caution symbol  — attached to each message.

When one of these messages is found, please take preventive measures for safety to carry out “SAFETY OPERATION AND PROPER MAINTENANCE OF THE UNIT”.



DANGER indicates an imminently hazardous situation which, if not avoided, will result in death or serious injury. This signal word is to be limited to the most extreme situations.



WARNING indicates a potentially hazardous situation which, if not avoided, could result in death or serious injury.

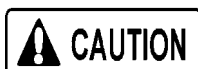

CAUTION indicates a potentially hazardous situation which, if not avoided, may result in minor or moderate injury. It may also be used to alert against unsafe practices.



IMPORTANT indicates important caution messages for the performance or durability of the unit, which has no concern to injury or accident of or to a human body.

Follow warnings mentioned in this manual. This instruction manual does not describe all safety items. We, therefore, advise you to pay special attention to all items (even though they may not be described in the manual) for your safety.

1.Safety

1.1 Caution before Operation

WARNING

- Read each instruction plate which is displayed in the manual or on the machine carefully, understand its content and follow the indications thereof.
- Keep the Safety Warning labels clean. When they are damaged or missing, apply new ones.
- Do not modify the machine without prior approval. The safety may be compromised, functions may be deteriorated, or machine life may be shortened.
- Never use the machine for the other purposes than power supply. Otherwise, serious accidents may occur.

Follow the safety instructions

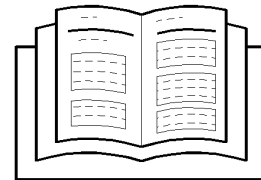

TR0086

WARNING

- Exhaust gas from the engine is poisonous, and could cause casualties when it is inhaled. Avoid using the machine in an insufficiently ventilated building or a tunnel.

Ventilation

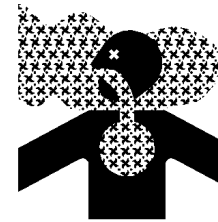

PC002

DANGER

- Keep flames away from battery.
- Battery may generate hydrogen gas and may explode.
- Battery electrolyte is dilute sulfuric acid. In case of mishandling, it could cause skin burning.
- Wear protective gloves and safety glasses when handling a battery.
- Dispose of battery, observing local regulations.

Handling battery



D004



TR0093

1.Safety

WARNING

- When handling machine, do not wear;
- loose clothes
- clothes with unbuttoned sleeves
- hanging tie or scarf
- dangling jewelry
- Such outfit could be caught in the machine or dragged in the rotating portion of the machine, and could cause a serious injury.

Safety outfit



TR0084

WARNING

Maintain both physical and mental health

- Do not operate the machine when you are tired or drunk or under the influence of drugs. Otherwise, a hasty conclusion or careless handling may cause unexpected injury or accident. Manage your physical and mental health and be cautious in handling the machine.

CAUTION

- Please wear protection implements, such as a helmet, protection glasses, earplugs, safety shoes, a glove, and a protection-against-dust mask, according to the contents of work for safety.

Protection equipments



TR0085

CAUTION

- Have first-aid boxes and fire-extinguishers near the unit ready for emergency situations such as injuries and a fire.
- It is advisable to have a list of phone numbers of doctors, ambulance and the fire department available in case of emergency.

Safety fittings



TR0096

CAUTION

Safety around the machine

- Such things as unnecessary equipment and tools, cables, hoods, canvas sheets and pieces of wood which are a hindrance to the job, have to be cleared and removed. This is because operators and personnel nearby may stumble on them and may be injured.

1.Safety

1.2 Caution during Operation



WARNING

Never touch the output terminals and interior of control board

- Never touch the output terminals during operation.
- Notice that the voltage of several hundreds volt is applied to the output terminal.
- When removing or connecting a connecting cable for changing load, be sure to switch OFF the circuit breaker, remove the starter key from the starter switch, then carry out a work. The operator must keep the key during operation.

Neglecting the cautions mentioned above, and a third party starting the machine during operation may cause serious accidents such as electric shock.



WARNING

Hands off from rotating parts and belts

- Keep hands off from the rotating portion or belts while running. It could cause serious injuries if hands should be caught in.

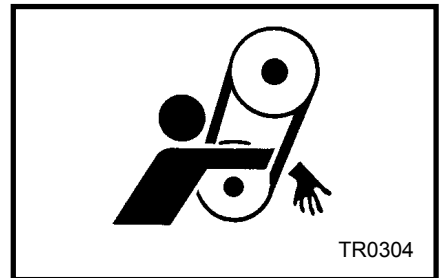

CAUTION

Do not remove radiator cap during operation

- Do not, under any circumstance, open the radiator cap while running or immediately after stopping operation. Otherwise high temperature steam jets out and this could cause scalding.

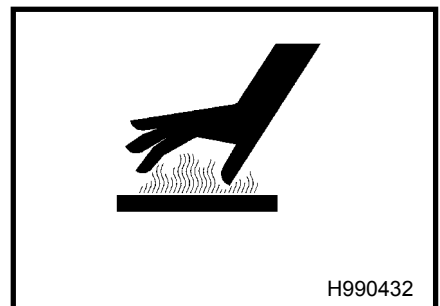

1.Safety

CAUTION

- Never work nearby hot portions of the machine while it is running.
- Do not touch hot portions of the machine while inspecting the machine when running.
- Such parts as engine, exhaust manifold, exhaust pipe, muffler, and radiator are especially hot, so never touch those parts, because it could cause scalding.
- Coolant water and engine oil are also very hot and dangerous to touch. Avoid checking or refilling them while the unit is running.

Do not touch hot parts



H990432

CAUTION

- Do not, under any circumstance, bring lit cigarettes or matches near such oils as diesel fuel oil, and engine oil, etc. They are extremely flammable and dangerous, so be careful when handling.
- Refilling oils should be done in an outdoor well-ventilated place.
- Refuel after stopping the engine, and never leave the fuel nearby the machine. Do not spill. It may cause a fire. When it is spilt, wipe it up completely.
- Do not supply fuel up to the fuel cap. And then the fuel may get spilt when the unit is moved, transported and it is vibrating.
- Such parts as muffler and exhaust pipe can be extremely hot. Remove twigs, dried leaves, dried grass and waste paper, etc. from the exhaust outlet of the muffler.
- Keep a fire extinguisher available by the machine in case of unexpected fire.

Fire prevention



D004



H990433

1.Safety

1.3 Cautions during Inspection and Maintenance

WARNING

Hang a “Now Checking and under Maintenance” tag

- Before starting inspection, switch off the circuit breaker of this machine, remove the starter key from the starter switch, and then hang a “Now Checking and under Maintenance” tag where it can be easily seen. The checker must keep the key during checking and maintenance.
- Remove the negative (-) side cable from the battery.
If the above procedure is neglected, and another person starts operating the machine during check or maintenance, it could cause serious injury.

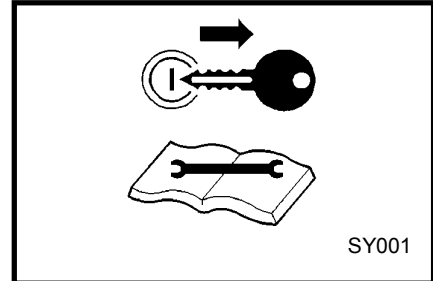

WARNING

Adjusting tension of fan belt

- Be sure to stop the engine and remove the starter key whenever the tension of the fan belt is to be adjusted.
- If the machine is running, it might catch the operator’s hand into the fan belts, and this could cause a serious injury.

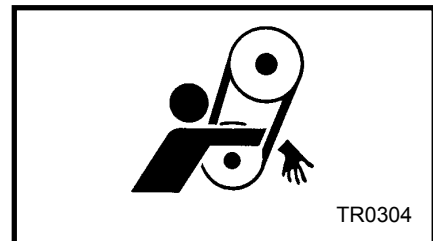

WARNING

Hands off from cooling fan

- Be sure to stop the engine and remove the starter key whenever the tension of the fan belt is to be adjusted.
- If the machine is running, it might catch the operator’s hand into the fan belts, and this could cause a serious injury.

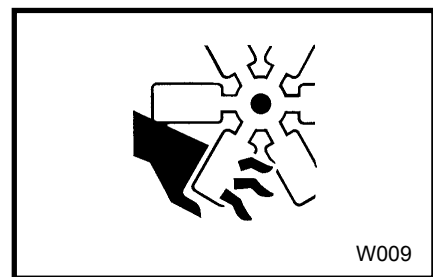

WARNING

Cleaning by air-blow

- When cleaning dust accumulated in such devices as the air-filter, etc., by blowing compressed air, wear safety glasses, etc. to protect your eyes.



1.Safety

CAUTION

- It is recommended to use a lamp with safety guard fitted where the site is dark. Operating the machine gropingly or by relying on one's intuition could cause unexpected accidents.
- Any lamps without safety guard are not recommended since they can be broken and they could ignite flammables such as fuel, etc.

Lighting apparatus

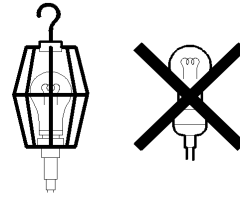

TR0206

CAUTION

- Be sure to stop the engine, and let the coolant water sufficiently cool down before draining it.
- If the drain valve is opened before the coolant water is cooled enough, hot water could jet out, and it could cause scalding.

Opening coolant water drain valve



H990432

CAUTION

- After stopping the engine, wait 10 to 20 minutes until the engine oil cools off. Then check the level of the engine oil, or refill or drain the oil.
- During operation or immediately after the engine stops, its oil is extremely hot and pressurized, so it may jet out when the cap is loosened. Be careful not to scald yourself from it.

Refilling or draining of engine oil



H990432

CAUTION

- When washing the machine, cover the control panel, generator and its electric parts to prevent them from being exposed to splashing water and avoid possible decrease in electrical insulation or other troubles to the machine.
- Dust, sand and dirt accumulated inside control panel could cause malfunction or trouble of the instruments. Clean them by blowing compressed air.

Caution of the cleaning

CAUTION

- Waste liquid from the machine contains harmful material. Do not discharge it onto the ground or into the river, lake or sea. Such material will pollute the environment.
- Be sure to use a container to hold the waste liquid from the machine.
- Be sure to follow the designated regulations when disposing of oil, fuel, coolant (antifreeze), filter, battery or other harmful materials.

Disposal of waste liquid, etc.









1.Safety

1.4 Safety Warning Labels

Following labels are attached to the machine.

Keep them clean at all times. If they are damaged or missing, immediately place an order with your nearest dealer for replacement. Part numbers are indicated on the lower right corner of the label.

Adhere a new one to the original location.

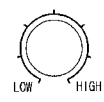
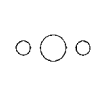
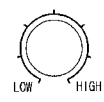
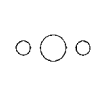
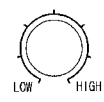
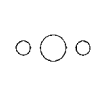
<p>1</p>  <p>LIFTING BAIL</p> <p>39176 69300</p>	<p>2</p>  <p>CAUTION</p> <p>PREVENT BURNING ACCIDENT</p> <p>Do not open radiator cap while it is still hot.</p> <p>39176 69600</p>	<p>3</p>  <p>WARNING</p> <p>BEWARE OF EXHAUST GASES</p> <p>When you operate machine INDOORS or in TUNNEL, provide good ventilation. Poor ventilation can cause fatal accident.</p> <p>39176 73300</p>	<p>4</p>  <p>WARNING</p> <p>Do not touch live electrical parts. Always wear dry insulating gloves. Do not operate the unit in the rain, around standing water or when wet. Maintain all electrical cords and connections in proper condition. Always ground the generator to earth before operating.</p> <p>39176 62000</p>						
<p>5</p>  <p>WARNING</p> <p>BEWARE OF ENTANGLEMENT</p> <p>Keep your hands AWAY from fan during operation. Entanglement in the fan can cause serious injury.</p> <p>39176 73500</p>	<p>6</p>  <p>CAUTION</p> <p>PREVENT BURNING ACCIDENT</p> <p>When work is required near hot parts, wait for the parts to cool down fully before starting work.</p> <p>39176 69500</p>	<p>7</p>  <p>WARNING</p> <p>BEWARE OF ENTANGLEMENT</p> <p>Keep your hands AWAY from moving parts such as V-belts, pulleys etc. Entanglement in them can cause serious injury.</p> <p>39176 73800</p>	<p>8</p>  <p>FLAMMABLES</p> <p>DIESEL FUEL</p> <p>EPA REGULATION</p> <p>LOW SULFUR OR ULTRA LOW SULFUR DIESEL FUEL ONLY.</p> <p>DIESEL A FAIBLE TENEUR EN SOUFRE OU DIESEL A TRES FAIBLE TENEUR EN SOUFRE UNIQUEMENT.</p> <p>39178 22030</p>						
<p>9</p> <table border="1"> <tr> <td data-bbox="220 1411 470 1489"> <p>MAIN CIRCUIT BREAKER</p> <p>Main breaker must be "ON" to power terminal connections and single-phase receptacle plugs.</p> </td> <td data-bbox="491 1411 699 1489"> <p>CAUTION</p> <p>DO NOT SWITCH WHILE UNIT IS RUNNING</p> </td> </tr> <tr> <td data-bbox="220 1512 343 1668"> <p>VOLTAGE ADJUSTER</p>  </td> <td data-bbox="359 1512 486 1668"> <p>CURRENT SELECTOR</p>  </td> </tr> <tr> <td colspan="2" data-bbox="220 1680 486 1803"> <p>WARNING</p> <p>Do not touch live electrical parts. Always wear dry insulating gloves. Do not operate the unit in the rain, around standing water or when wet. Maintain all electrical cords and connections in proper condition. Always ground the generator to earth before operating.</p> </td> </tr> </table> <p>39178 50820</p>				<p>MAIN CIRCUIT BREAKER</p> <p>Main breaker must be "ON" to power terminal connections and single-phase receptacle plugs.</p>	<p>CAUTION</p> <p>DO NOT SWITCH WHILE UNIT IS RUNNING</p>	<p>VOLTAGE ADJUSTER</p> 	<p>CURRENT SELECTOR</p> 	<p>WARNING</p> <p>Do not touch live electrical parts. Always wear dry insulating gloves. Do not operate the unit in the rain, around standing water or when wet. Maintain all electrical cords and connections in proper condition. Always ground the generator to earth before operating.</p>	
<p>MAIN CIRCUIT BREAKER</p> <p>Main breaker must be "ON" to power terminal connections and single-phase receptacle plugs.</p>	<p>CAUTION</p> <p>DO NOT SWITCH WHILE UNIT IS RUNNING</p>								
<p>VOLTAGE ADJUSTER</p> 	<p>CURRENT SELECTOR</p> 								
<p>WARNING</p> <p>Do not touch live electrical parts. Always wear dry insulating gloves. Do not operate the unit in the rain, around standing water or when wet. Maintain all electrical cords and connections in proper condition. Always ground the generator to earth before operating.</p>									

1.Safety

- The pasting position of safe warning label is as follows.

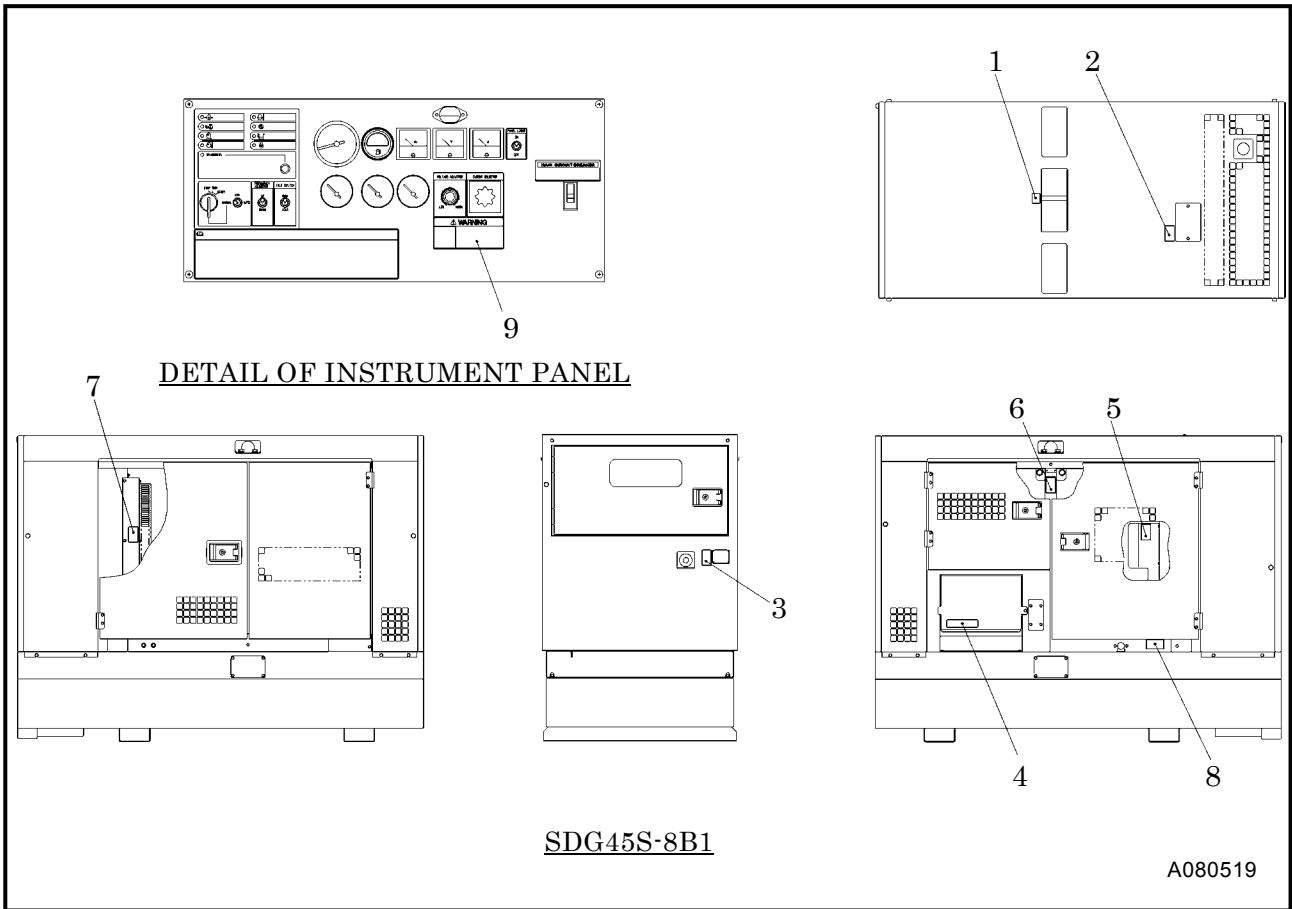

2. Part Names

2.1 Internal Components

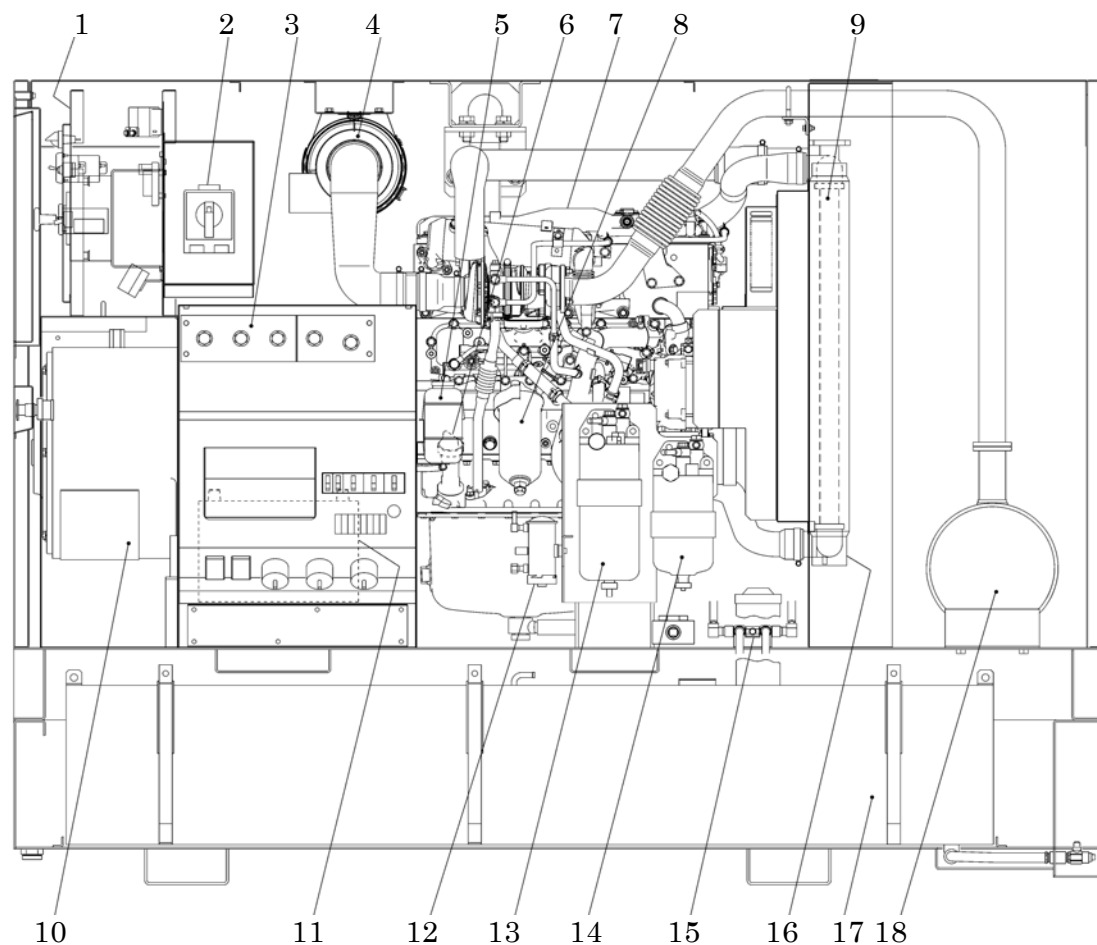

SDG65S-8B1

No.	Description	Function
1	Control panel	Panel fitted with various meters and controllers.
2	Voltage selector switch	For selecting output voltage.
3	Output terminals	Equipped with three phase and single phase terminal and receptacle for single phase.
4	Air filter	Filtering device for filtering dust floating in intake air.
5	Reserve tank	For feeding cooling water.
6	Engine oil filler port	For supplying and replenishing engine oil to engine.
7	Engine	For driving the generator main unit.
8	Engine oil filter	For filtering engine oil.
9	Radiator	For cooling engine.
10	Generator main unit	For generating AC power to be supplied.
11	Battery *	For electrically starting engine.
12	Air bleeding electromagnetic pump	For feeding diesel fuel oil to engine.
13	Fuel pre- filter	For filtering the fuel before fuel filter
14	Fuel filter	Filtering device for filtering dust mixed in fuel oil.
15	Selector valve of fuel pipe	For supplying fuel oil from the tank provided outside.
16	Intercooler	For cooling the air heated by engine. (Only as for SDG65S)
17	Fuel tank	Fuel oil container.
18	Exhaust muffler	Equipment which muffles an engine exhaust sound.

Instrument 11 marked “*” are provided on the other side (opposite side of maintenance).

3. Installation

3.1 Transporting Unit



Transportation

- Use the lifting bail “1” at the center of bonnet for hoisting up and down the machine.
Since the rope hook is not strong enough to be used for hoisting, never use it to prevent falling accident.
- When transporting the machine, be sure to put it on the truck bed and use the rope hooks to secure it with rope
- Do not hoist up the machine while it is running. Otherwise, a fatal trouble or serious accident may occur.

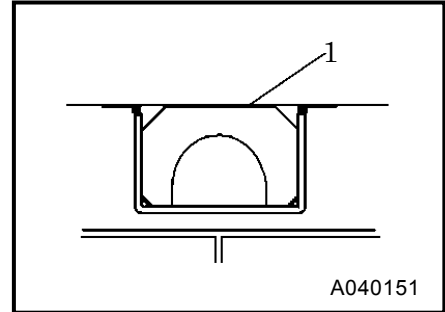

3.1.1 Lifting

- Use the lifting bail “1” fitted on center of bonnet.
- Select an appropriate crane or truck by referring to the mass and dimensions mentioned in “Specifications”.
- Only a qualified crane operator is allowed to operate a crane.

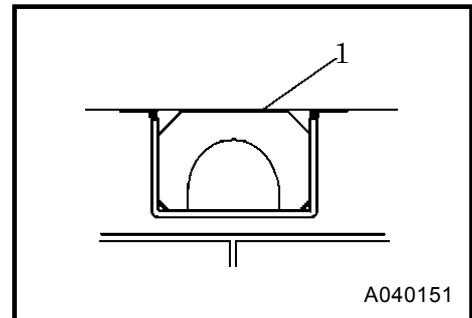

3. Installation

3.2 Conditions of Unit Installation

⚠ WARNING

Ventilation

- Exhaust gas from the engine is poisonous, and it could cause casualties when it is inhaled.
Avoid using the machine in an insufficiently ventilated building or a tunnel. When the machine is unavoidably used in such insufficiently ventilated place, ventilation devices and ventilation pipe should be provided for better ventilation.

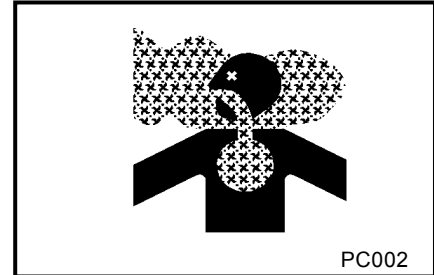

⚠ WARNING

In case that the unit is installed indoors

- In case that the unit is installed indoors for operation, suction air port and exhaust fume outlet port should be provided for better air ventilation.
- Make sure to secure enough space in front of air suction port and also to secure it after exhaust fume outlet port so that the engine may not get overheated.
- Exhaust fume pipe extension should be provided to send exhaust fume out of the installation place.

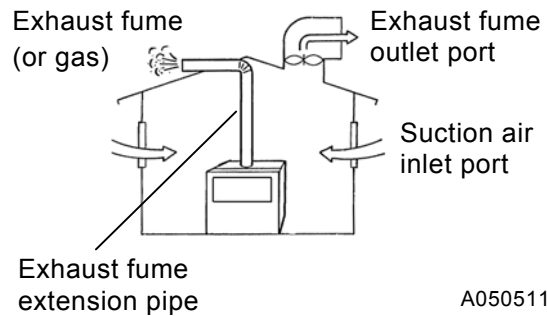

⚠ WARNING

Installing the unit st such poorly-ventilated place

- In case that the unit is installed inside any tunnel, make sure to provide fresh air and ventilate it.
- In this case, make sure to extend the exhaust fume pipe outdoors, and also make sure to prevent any leak from any connection pipes. In case that the unit is operated under exhaust air pressure, make sure to install the exhaust pipe to be supported.

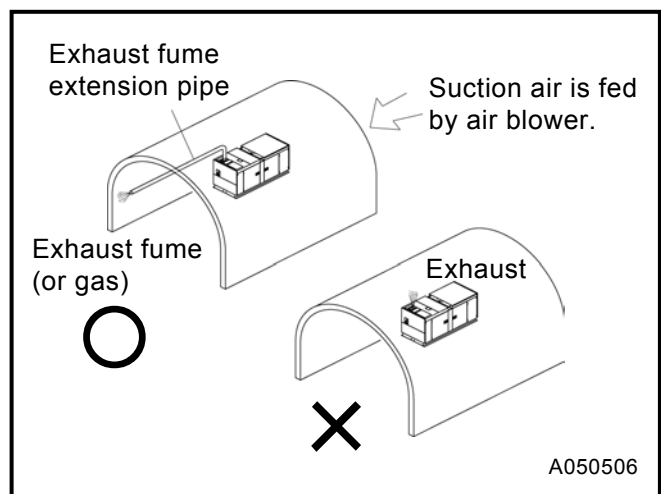

3. Installation

WARNING

- Never locate the unit with the exhaust muffler facing any private house:
- As the exhaust fume (gas) from the engine is poisonous, never direct it to any other persons passing by.

How to locate the unit

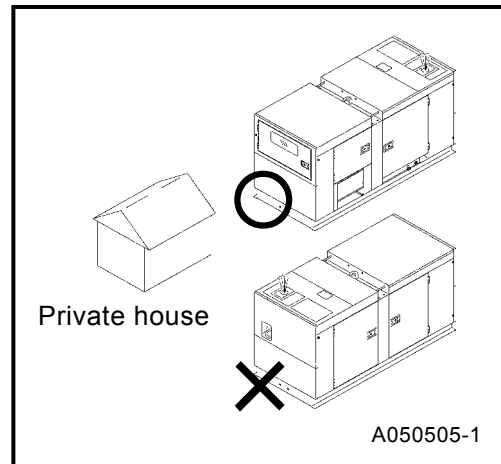

WARNING

- The machine has to be installed on dry, firm, and level area.
- Avoid installing the machine in a place such as a damp place or a place where puddles are apt to be formed after rain. Such installation could cause electric shock.
- When installing the machine at the sea shore or on a ship, make sure that the machine should not be exposed directly to sea water.
- When installing the machine at a sandy place, make sure that exhaust from the generator or radiator does not blow the sand up in the air, or into the machine.
- In case that the unit has to be installed inevitably on any rough and uneven ground; it is necessary to insert square wooden bars under the unit for levelling it.

Installation

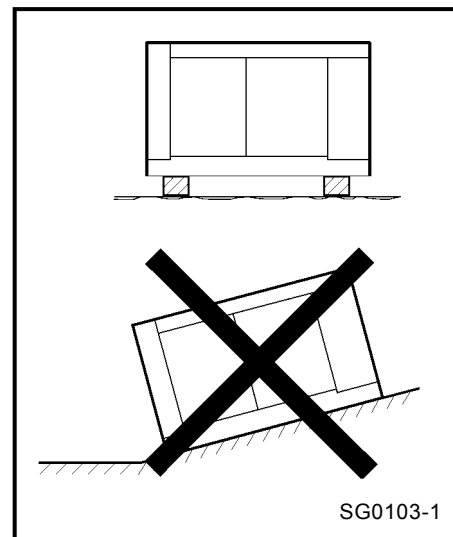

- The machine should be operated in following conditions:
 - Ambient temperature ----- -15°C to $+40^{\circ}\text{C}$
 - Humidity ----- Less than 85%
 - Altitude ----- Lower than 500 m above sea level
- If more than two machines are placed parallel in operation, keep enough distance so that exhaust air from one machine does not effect the other one.
- Keep enough space around the unit for inspection and maintenance access.

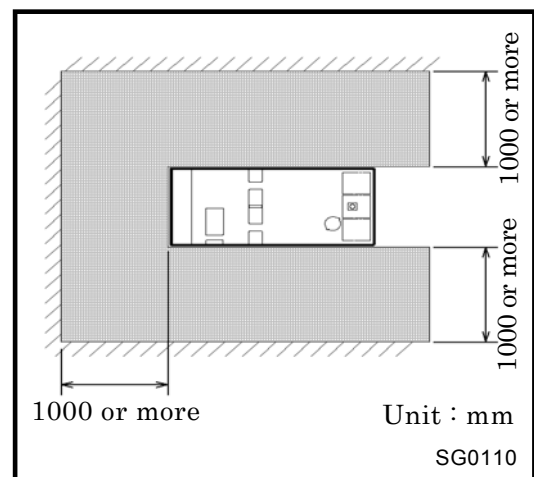

3. Installation

CAUTION

- In order to prevent from entering the jobsite or touching the equipment any other persons than the persons engaged in the job, please prepare for safety fences around the unit:

Preparation of safety fences

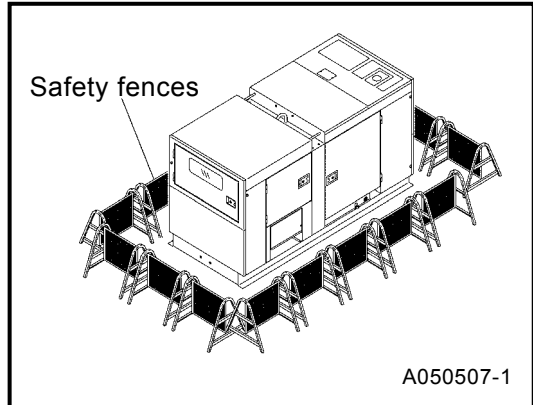

A050507-1

3. Installation

3.3 Grounding Method

3.3.1 Ground Terminal

The generator ground terminal “1” is connected to the frame of the generator, metal non-current-carrying generator parts and the ground terminals of each receptacle.

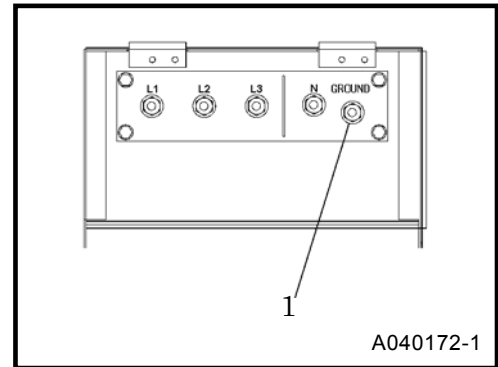

3.3.2 Connections to a Building's Electrical System

Connections for standby power to a building’s electrical system must be made by a qualified electrician. The connection must isolate the generator power from utility power, and must comply with all applicable laws and electrical codes.

WARNING

- Improper connections to a building’s electrical system can allow electrical current from the generator to backfeed into the utility lines. Such backfeed may electrocute utility company workers or others who contact the lines during a power outage. Consult the utility company or a qualified electrician.
- Improper connections to a building’s electrical system can allow electrical current from the utility company to backfeed into the generator. When utility power is restored, the generator may explode, burn, or cause a fire in the building’s electrical system.

3.3.3 Ground System

AIRMAN’s generators have a system ground that connects generator frame components to the ground terminals in the AC output receptacles. The AC neutral wire is connected to the system ground.

3. Installation

3.3.4 GFCI (Ground-fault circuit interrupter) Receptacles



- Using the generator in rain, snow or near water can lead to death from electric shock. Keep the generator dry.

All of the 20 ampere 120 volt receptacles on the generator are protected by a GFCI (Ground-fault circuit interrupter) for protection against the hazards of ground fault currents. An example of ground-fault current is the current which would flow through a person who is using an appliance with faulty insulation and, at the same time, is in contact with an electrical ground such as a plumbing fixture, wet floor, or earth.

The ground-fault circuit interrupter will not protect against short circuits or overloads. The circuit breaker in the control panel which supplies power to the circuit provides that protection.

The ground-fault circuit interrupter can be identified by the TEST and RESET buttons. The receptacles on the GFCI can be tested with the TEST and RESET buttons.

TEST BUTTON: To test, depress the “TEST” button. (power is turned off)

RESET BUTTON: To restore power, depress the “RESET” button.

Perform this test monthly or every 250 hours operation whichever comes first, in order to ensure proper operation of the GFCI receptacle. If the generator is stored outdoors, unprotected from the weather, test the GFCI receptacle before each use. Record your test on the GFCI test card provided on the control panel.

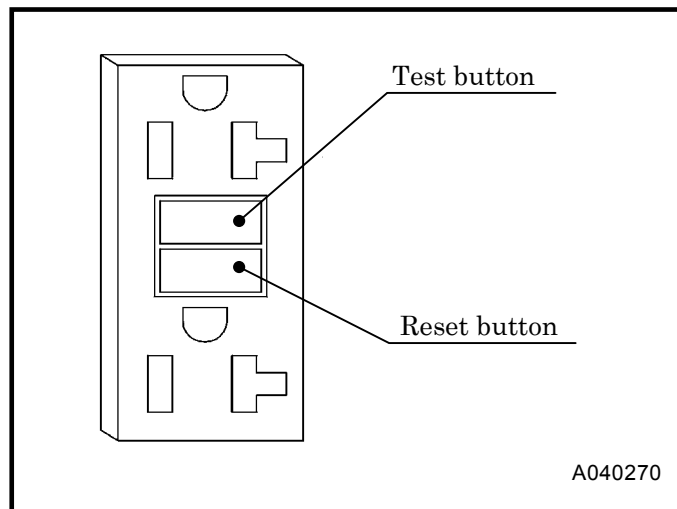

3. Installation

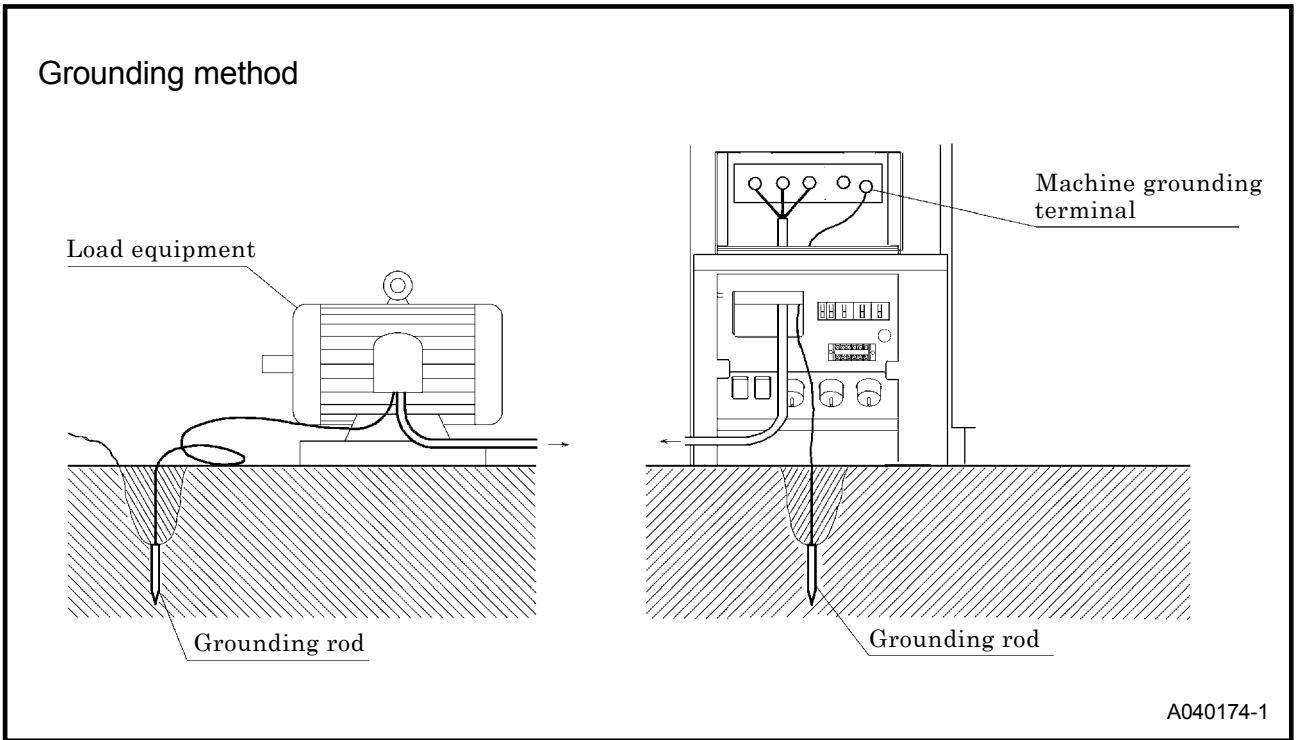

3. Installation

3.4 Selecting Cable

- Select a cable with sufficient diameter by considering the permissible current on the cable and the distance from the generator to the load.
- If the current flowing to the load exceeds the permissible current of the cable, resultant overheating may burn the cable. Similarly, if the cable is too small in thickness to the length, the input voltage to the load will fall to cause the load input power to drop, as a result, the performance of the machine cannot be displayed.

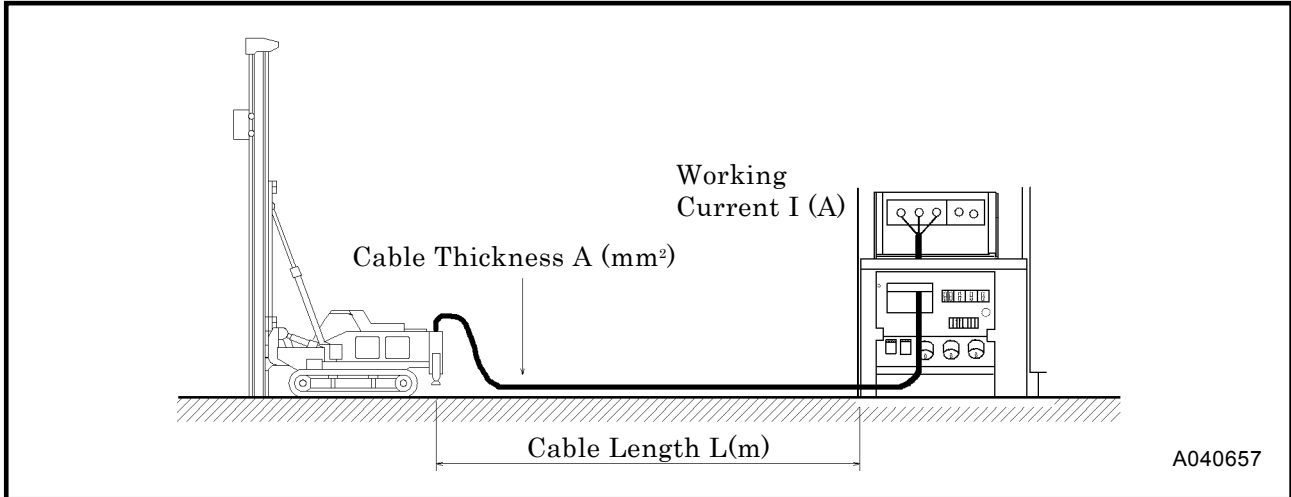

- Simplified three-phase three-wire formula to seek voltage drop from cable length and working current. Select such a cable length and thickness so that the voltage drop will remain less than 5%.

Output system	Voltage drop	e : Voltage drop(V) e' : Voltage drop between an outside line or one line of each phase, and a neutral line (V) A : Cable thickness (mm ²) L : Cable length (m) I : Working current (A)
Three-phase 3-wire Type	$e = \frac{30.8 \times L \times I}{1,000 \times A}$	
Three-phase 4-wire Type	$e' = \frac{17.8 \times L \times I}{1,000 \times A}$	

- The following tables show the relations between the cabtyre cable length and the cable thickness (nominal cross-sectional area) suited to the working current.

(Based on the condition that working voltage is 200 V, with voltage drop of 10V.)

Single-Conductor Cabtyre Cable

Unit:mm²

Current \ Length	50m	75m	100m	125m	150m	200m
50A	8	14	22	22	30	38
100A	22	30	38	50	50	60
150A	38	38	50	60	80	100

Three-Conductor Cabtyre Cable

Unit:mm²

Current \ Length	50m	75m	100m	125m	150m	200m
50A	14	14	22	22	30	38
100A	38	38	38	50	50	60
150A	22×2	22×2	38×2	38×2	38×2	50×2

3. Installation

3.5 Selector Valve of Fuel Pipe

CAUTION

- Always keep watching the fuel feeding conditions while feeding fuel from a separate fuel storage tank separately installed.
- In order to use a separator fuel storage tank, be sure to change the handles of the selector valves to a predetermined position. If you make a mistake in turning the handles, it can burst the fuel pipe and cause overflowing. It could lead to a serious accident.
- If excessive force is loaded to the selection handle, it will not move smoothly and it could cause fuel leakage. Be careful about the handle.

3.5.1 Selector valve

This valve is designed to feed fuel directly to the engine of the unit, not from the tank integrated in the unit, but from a fuel tank installed separately.

3.5.2 Operation method

- ① Unit is delivered from factory with fuel line piping and selector valves built in as shown in the following Fig.1. When operating a unit, using installed fuel tank, run the machine with the fuel line piping and the handles of selector valves factory-arranged.
- ② When using a separate storage tank, remove the plug fitted at the connections to the separator tank and make piping as shown in Fig.2. And then turn the handles of the selector valve as shown in Fig.2.
- ③ When removing the piping connections, make sure to return the handles to the original positions shown in Fig.1 and install the plugs.

3.5.3 Installation of Separate Storage Fuel tank and piping method

- ① Use oil resistant hoses of inside diameter of 8mm to 10mm.
- ② Install the fuel tank so that the fuel level of the tank may be kept at the level from zero to 2.5m high from the machine installation level.
- ③ In order to avoid suction of water and sediment together, install the suction pipe so that the inlet port of suction pipe may be kept at the 15mm to 20mm higher level than the bottom line of the tank. Also install the outlet port of the return pipe inside the tank.(see Fig.2 · A)
- ④ When refilling fuel in the tank, take much care not mix water and sediment.

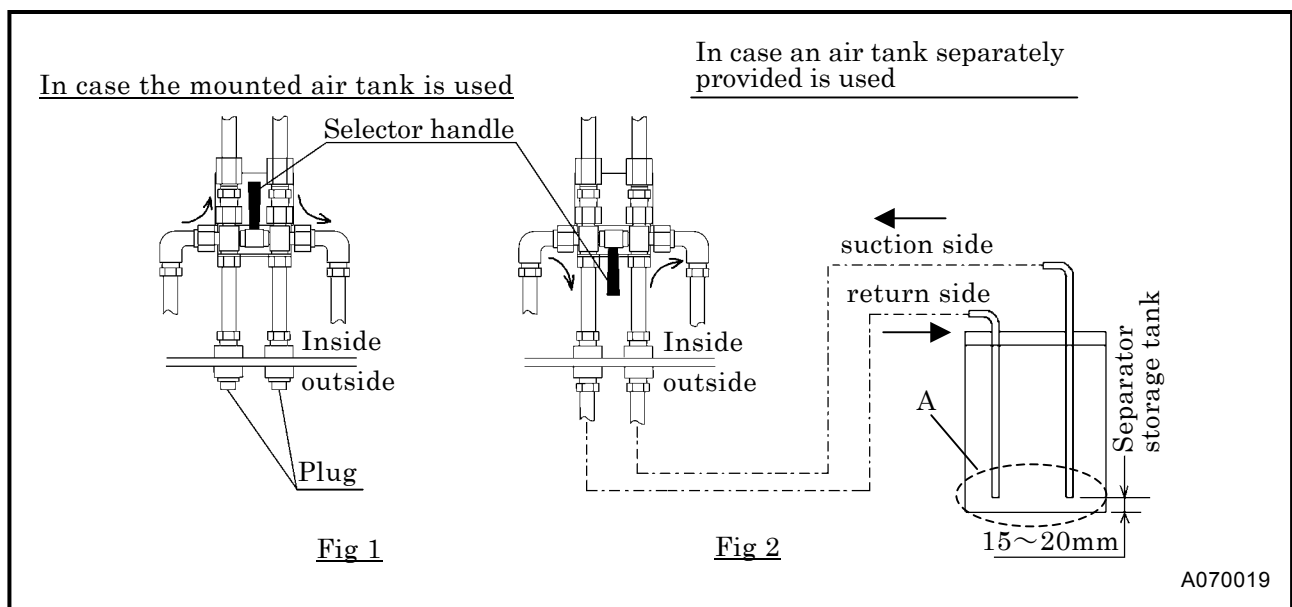

A070019

4. Operation

4.1 Instrument panel

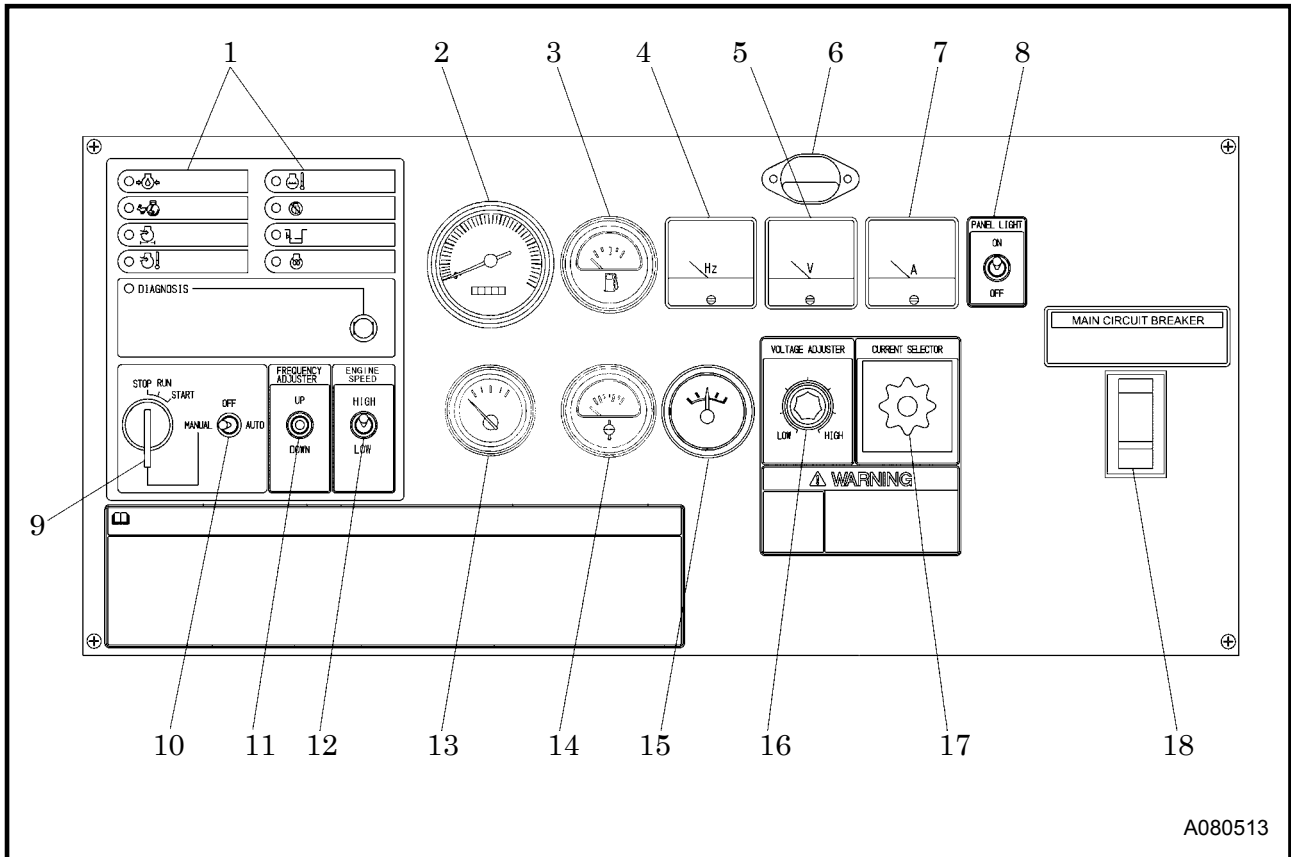

1. Monitor lamp (for details, see 4.2.1)
2. Tachometer with hourmeter
3. Fuel gauge
4. Frequency meter
5. Voltmeter
6. Panel light
7. Ammeter
8. Panel light switch
9. Starter switch
10. Manual-automatic change-over switch
11. Frequency adjuster switch
12. Engine speed switch
13. Engine oil pressure gauge
14. Coolant temperature gauge
15. Ammeter for battery charge
16. Voltage regulator
17. Ammeter change-over switch
18. Main circuit breaker

※ The voltage selector switch is provided inside the unit. (See page 2-1, No.2)

4. Operation

4.2 Protection device



WARNING

- For prevention of troubles during operation, this machine is provided with various protection devices. When the engine stops due to function of the protection devices and circuit breaker trips, get rid of the causes of trouble, referring to the trouble shooting clause and then restart operation.

4.2.1 List of protection devices

- This machine is equipped with the following devices in the table. Repair and make necessary treatment in accordance with the item ○.

Item	Engine stops	Three-phase circuit breaker trips.	Lamp display	Monitor	Functions
Engine oil pressure drop	○	—	○		When engine oil pressure drops, it functions. Operating pressure: lower than 15psi (0.1MPa)
Engine water temperature rises.	○	—	○		In case of abnormal rise of engine water temperature, it functions. temperature reaches: more than 221° F (105°C)
Excessive rotation	○	—	○		When engine rotates excessively, it begins to function. Function rotation At 50Hz operating:1,725min ⁻¹ (57.5Hz) At 60Hz operating:2,070min ⁻¹ (69Hz)
Overcrank	○	—	○		This lamp goes on when operator fails to start engine, during automatic operation mode.
Clogging of air filter	—	—	○		When air filter is clogged and it becomes necessary to clean it, it functions.
* Oil Fence	—	—	○		When more condensate (fuel, engine oil and coolant) than 1/3 of capacity in the oil fence is accumulated, monitor lamp lights.
Boost temperature	—	—	○		When boost temperature rises higher than 85°C, the lamp goes on.
Overcurrent or short circuit	—	○	—	—	In case of overload or short circuit accident, it functions.
Diagnostic lamp	—	—	○	DIAGNOSIS	This lamp blinks when engine trouble happens. Then, a pattern of lamp signals changes if “DIAGNOSTIC BUTTON” is pushed. The pattern of lamp signals shows what’s kind of trouble happens.
Engine troubles	—	—	○	—	Refer to 6.2.1 “Engine troubles”

* When the monitor lamp lights in the oil fence, immediately drain it.

(For the capacity of the oil fence, refer to 8.1 Specifications). To protect environment, do not drain it directly into rivers. (For details, see 4.4)

4. Operation

4.2.2 Three-phase circuit-breaker

- In case overload and short-circuited wire connection should occur, the circuit-breaker trips.
- When this is tripped, stop the unit immediately and reset the circuit breaker after getting rid of the causes of trouble.

<How to reset>

- In order to reset the lever of circuit-breaker, press hard the lever downward till the lever sounds “click”.

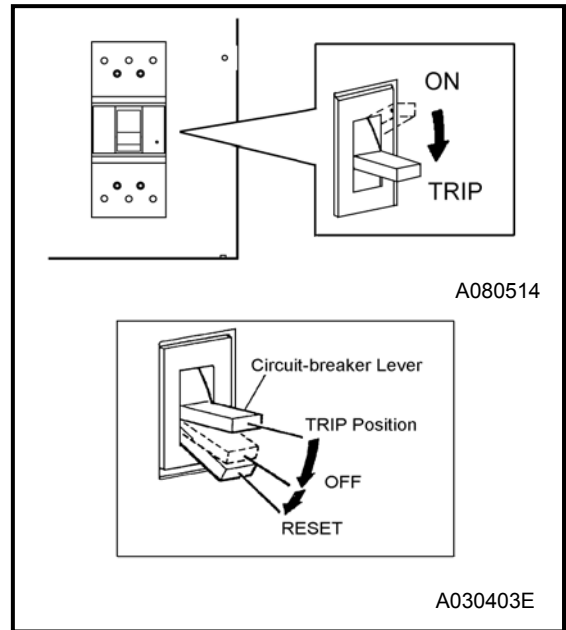

4.2.3 Thermal relay

- In case overload or short-circuit should occur to load or load connection cable, this relay functions to trip the circuit-breaker.
- It is not necessary to push the reset button even after the three phase main breaker is tripped since the thermal relay is set automatic return at factory.

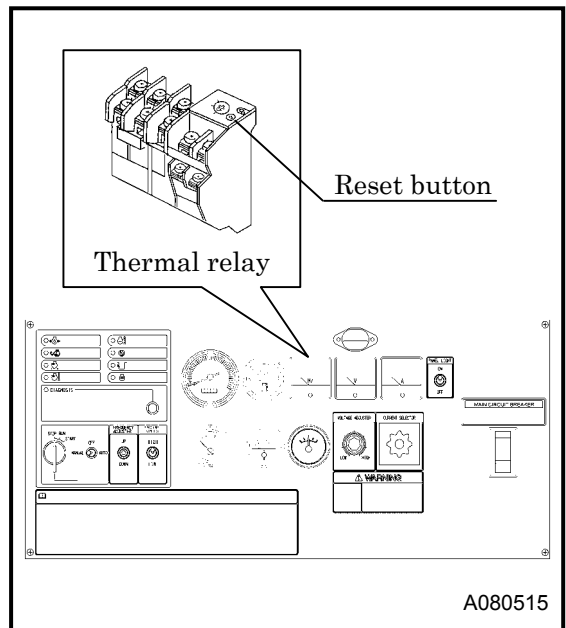

4. Operation

4.2.4 Circuit protector (CP) for AVR protection

AVR is equipped with circuit-protector (CP) for protection against overcurrent. Under the following cases, it happens to function.

- In case the machine gets overloaded while engine speed is still lower.
- In case the output voltage of generator is increased higher than the specified voltage.

< Symptom >

- When circuit protector functions and load is applied to the machine, such trouble as larger variance of voltage and/or delayed voltage recovery follow.

< How to reset >

- Press the white colored AVR button inside the control panel for resetting the circuit-breaker.

Note: Do not hold the button with such sharply pointed things as a screwdriver, ball point pens etc.

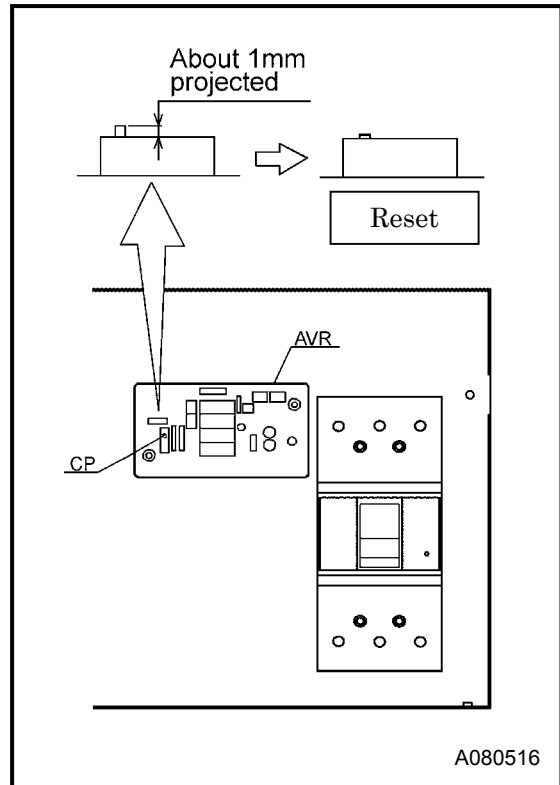

4. Operation

4.3 Connecting Load

WARNING

Electric shock and electric leak

- Make sure not to connect the output terminal of the machine with the commercial power source from electric power company. It may cause an electric shock, machine troubles and even a fire.
- Make sure to ground the machine and the load. It could cause an electric shock when the machine is installed at a damp place or on a steel frame or a steel plate.
- Never touch the output terminals during operation.
- Notice that the voltage of several hundreds volt is applied to the output terminal.
- When removing or connecting a connecting cable for changing load, be sure to switch OFF the circuit breaker, remove the starter key from the starter switch, then carry out a work. The operator must keep the key during operation.
- For a connecting cable to load, do not use a cable with damaged sheath nor an inappropriate insulation cable to the voltage.
Secure connections between each cable terminal and input/output terminal. Otherwise, it may be slackened during operation and may cause a fire or an electric shock accident.

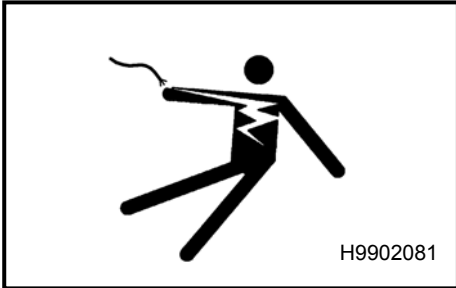
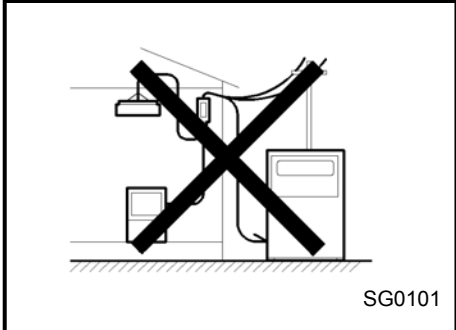

CAUTION

- When using a single-phase load [277V or 139V], see to it that the loads on the different phases will be evenly balanced. Unbalanced loads may cause the generator burning.
- Select a cable with sufficient diameter by considering the load capacity and the distance from the generator to the load. Use terminals for connection and securely fasten them.
- After checking phase number and voltage of the load, make sure to connect them correctly.

—Terminal size—

Three-phase output (L1,L2,L3,N)	M14
Leakage relay ground terminal(G)	M14

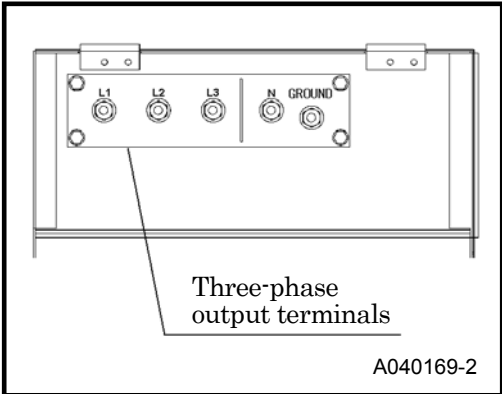

4. Operation

- Install a switch between the output terminal and the load to switch on/off the load. Do not switch the load on/off directly by the circuit-breaker of the generator. It could cause damage to the circuit-breaker.
- Connect the connecting cable to the load so that the output terminals should not touch each other.

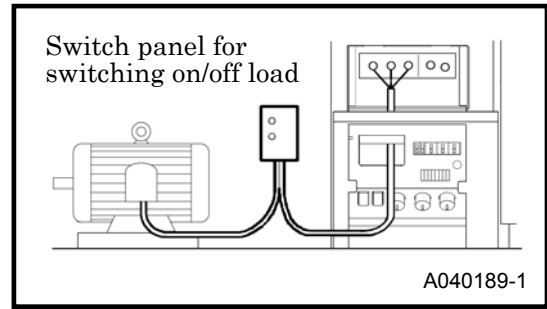

4.3.1 Proper Connection of Three-phase Four-wire Type Terminal



Never use voltage selector switch during operation

- During operation, do not operate voltage selector switch. Voltage selection during operation may cause abnormal voltage on the load side to damage the load and may cause a fire.
- In addition it could cause damage to generator and automatic voltage regulator (AVR).
- Be sure to shut off generator before using voltage selector switch.
- When voltage selection is completed, lock the voltage selector switch in position to prevent anyone from operating it.

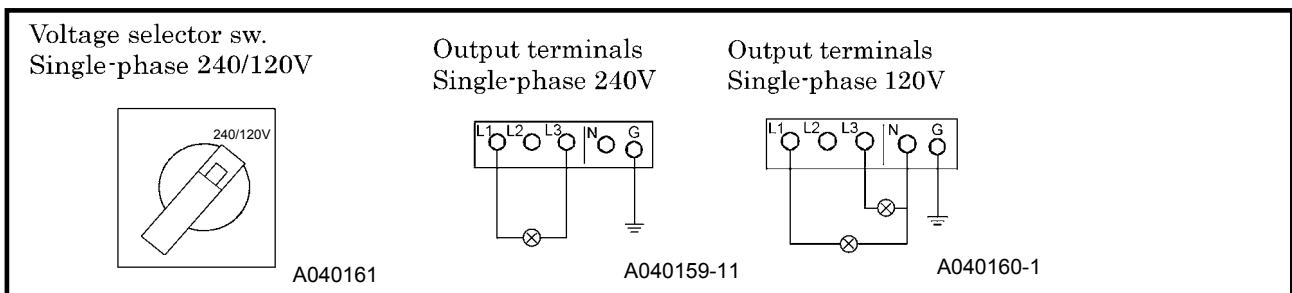
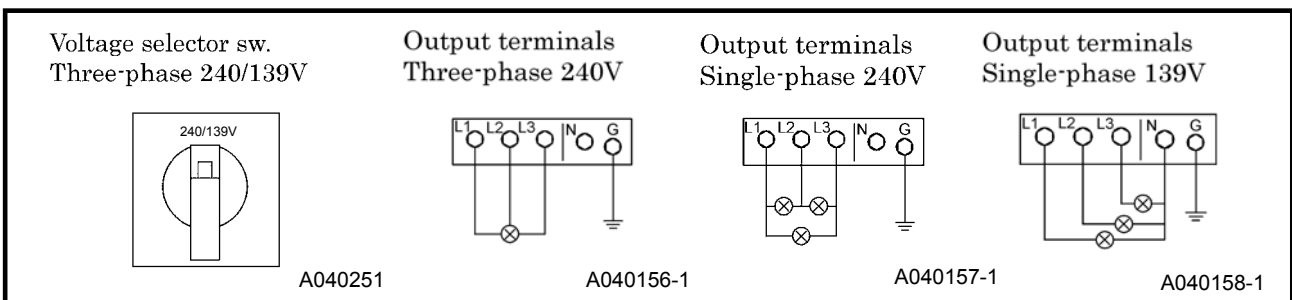
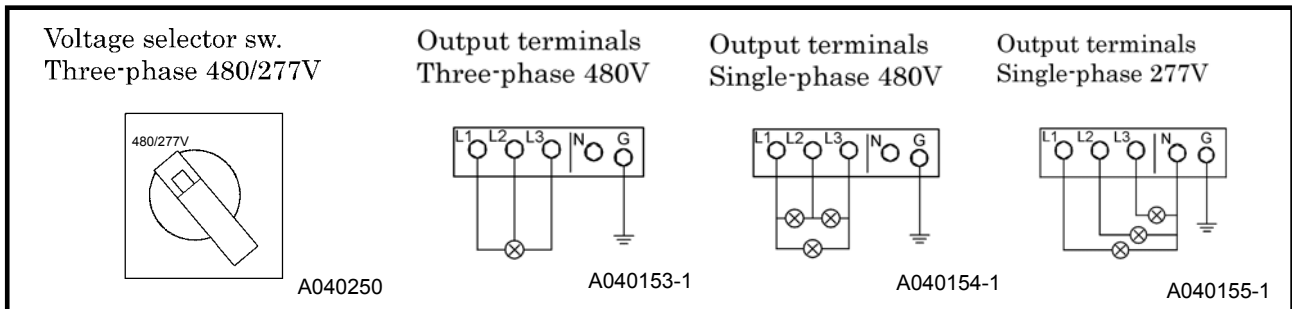
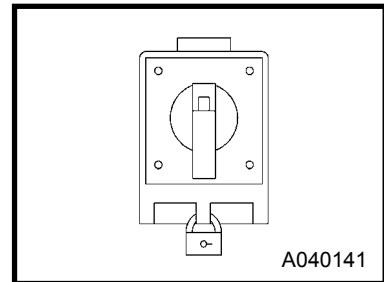

NOTE: When the voltage selector switch is in the single-phase 240/120V position, place the ammeter change-over switch to the L1 or L3 position to read the output.

4. Operation

4.3.2 Auxiliary AC Power

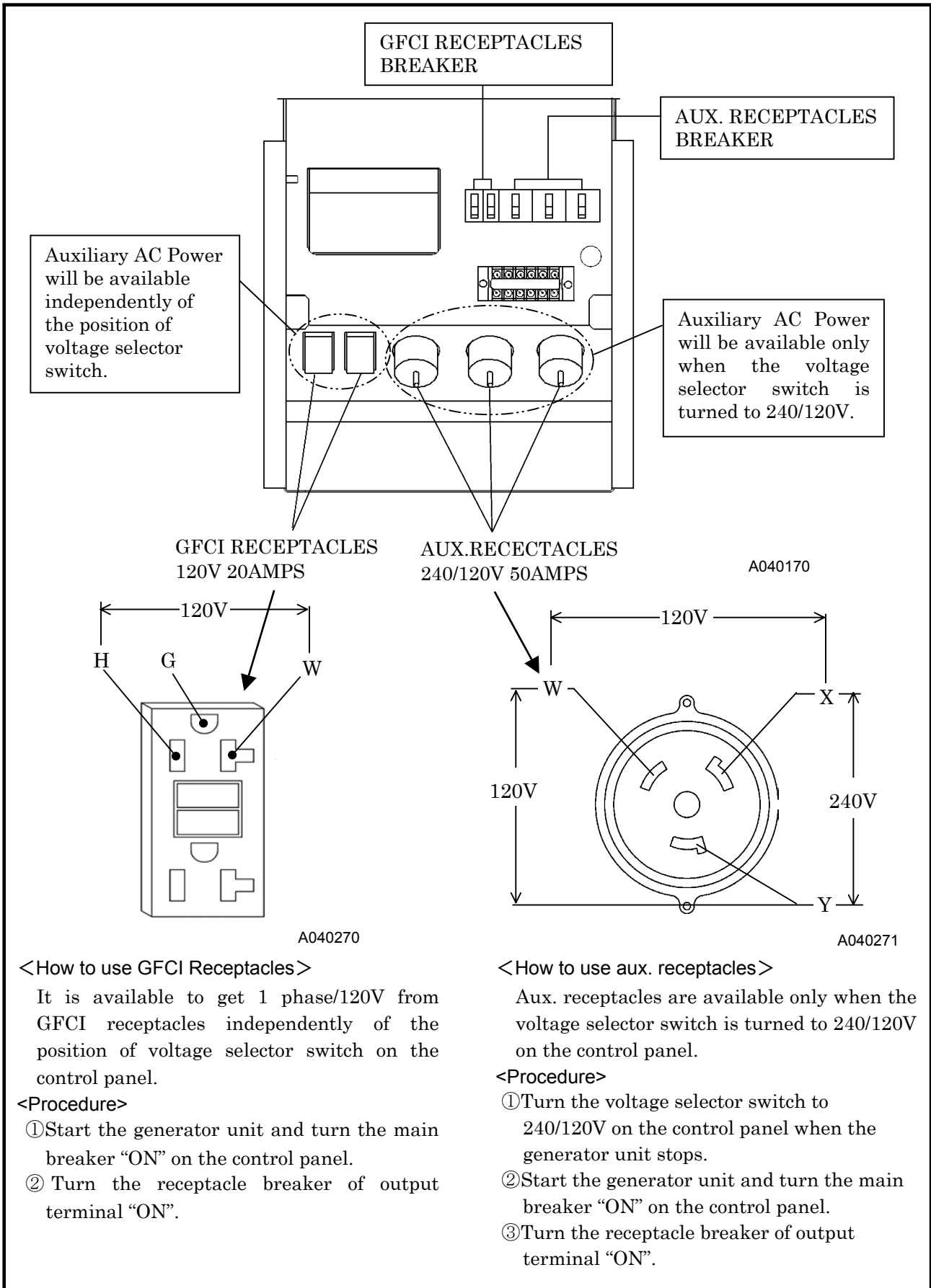

4. Operation

4.3.3 The Maximum Combined Simultaneous Power Consumption

CAUTION

- Never exceed the maximum combined simultaneous power consumption.

The following chart shows the maximum power available from the 120V-20A GFCI receptacles during simultaneous consumption (main terminals and receptacles) for both single or three phase settings. Values shown in the left column give the maximum current available at the 120V-20A GFCI receptacles compared to the value of the simultaneous current consumption from the main terminals.

Single Phase 120V-20A GFCI Rcept.	SDG45S		SDG65S	
	Three Phase 240/480V	Three Phase 240/480V	Single Phase 240/120V	Single Phase 240/120V
kW	kVA	kVA	kW	kW
0.0	45.0	26.0	63.0	36.5
1.2	40.9	24.8	59.0	35.3
2.4	36.7	23.6	54.9	34.1
3.6	32.6	22.4	50.7	32.9
4.8	28.4	21.2	46.6	31.7

4.4 Engine Oil • Coolant • Fuel

4.4.1 Engine Oil

IMPORTANT

- Viscosity of engine oil greatly affects startability, performance, oil consumption of the engine, as well as wear of the moving parts.
- Choose appropriate oil based upon the table below according to the outside air temperature.

Relation between viscosity (SAE) and temperature

SAE Viscosity number	Temperature
10W	-22° F to 50° F (-30°C to 10°C)
30	14° F to 104° F (-10°C to 40°C)
40	32° F to 122° F (0°C to 50°C)
15W/40	-4° F to 104° F (-20°C to 40°C)

- Be sure to use CD class engine oil or superior class. (Using engine oil with poor quality may shorten the life of the engine).
- When two or more different brands of oil are mixed, its performance can be deteriorated. Do not mix oils.
- Follow the designated regulations to dispose of engine oil.

4. Operation

4.4.2 Coolant

IMPORTANT

Quality of coolant and antifreeze

- Use soft water of good quality such as tap water for coolant.
- When water with dirt, sand, and/or dust contained, or hard water such as well water (ground water) is used, this will cause deposits inside radiator or on cylinder head, and will cause engine overheat due to poor flow of coolant.
- When the unit is used in a cold region and possible freezing is expected, it is recommended to use LLC (Antifreeze) for the coolant.
- Adjust mixing ratio of LLC with water according to the temperature.
- Use LLC within the range of its mixing ratio between 35 and 60%.
- If LLC in the water exceeds more than 60%, it may decrease its antifreezing effect.
(Upon delivery from the works, LLC density is 55%)
- Follow the designated regulations to dispose of LLC (Antifreeze).

4.4.3 Fuel

IMPORTANT

Choose appropriate fuel

- The following specific advantages are required for the diesel fuel.
 - Must be free from minute dust particles.
 - Must have adequate viscosity.
 - Must have high cetane value.
 - Must have high fluidity at low temperature.
 - *Low sulfur or ultra low sulfur diesel fuel only.
 - Must have little residual carbon.
- *EPA regulations

4. Operation

4.5 Check before Starting the Machine



WARNING

Check before starting the unit

- Be sure to check the machine before operation.
When any abnormality is found, be sure to repair it before starting the unit.
- Be sure to make daily check before operation. If the unit is operated without prior check and without noticing its abnormality, such operation could cause seizure of components or may even cause fire.

4.5.1 Check engine oil level

- The machine should be on level before checking oil level.
- When you check oil level after you have once started operation, wait 10 to 20 minutes after stopping engine, before checking the oil level.

<Procedures>

- ① Pull out the engine oil level dipstick, and wipe it with a clean cloth.
 - ② Then, re-insert the dipstick fully and pull it out again. If the gauge shows the oil level between MAX and MIN limits, it is normal.
 - ③ When the oil level is below its MIN, add engine oil. (See 5.5.1.)
- While checking oil level, check also for contamination. If the oil is found dirty, contaminated, or should be changed according to the periodic inspection list, change the oil.

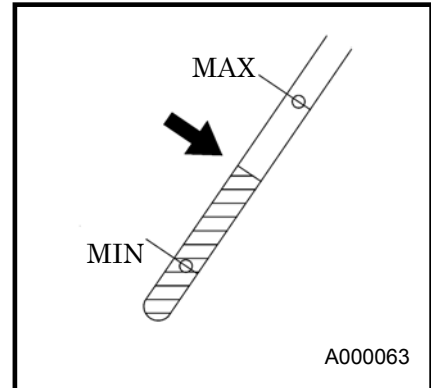

4.5.2 Check coolant level



CAUTION

Taking off the radiator cap

- Be sure to stop the machine first and then loosen the radiator cap slowly, after the coolant water is sufficiently cooled and the inner pressure is released.
If this procedure is neglected, its inner pressure can blow off the cap, and steam jetting out of the radiator could cause scalding.

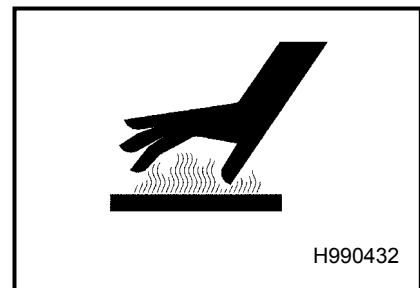

- Check the coolant level in the reserve tank. If it is lower than the limit, open the cap and replenish the coolant.
(Level must be kept above LOW mark)
- If little coolant is left in the reserve tank, replenish the tank and radiator also. (See 5.5.16)

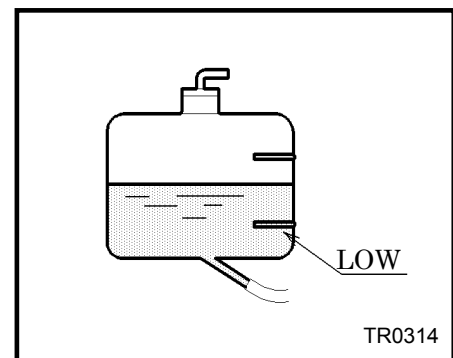

4. Operation

4.5.3 Check Fuel

- Before starting operation, make sure to check the level of residual fuel so that fuel shortage during operation can be avoided.
- If necessary, drain condensate accumulated at the bottom of the fuel tank.

CAUTION

- Do not, under any circumstance, bring lit cigarettes and/or matches to the fuel.
- The fuel is extremely flammable and dangerous. Be careful of fire because it is very likely to catch fire.
- Refuel only after stopping the engine, and never leave open fuel can near the machine. Do not spill. It could cause a fire. When it is spilt, wipe it up completely.
- Refilling fuel tank should be done in an outdoor well-ventilated place.
- Do not supply fuel up to the fuel cap. And then the fuel may get spilt when the unit is moved, transported and it is vibrating.

Fire prevention



4.5.4 Check fuel pre-filter drain

Check if the red float “2” in the fuel pre-filter rises up to the water drain level, then drain water if it is near the element “1” .

< Procedures >

- ① Loosen the drain plug “4” to drain the water.
 - ② After draining the condensate, be sure to fasten the drain plug “4” .
- Do not take away the case “3” of fuel pre-filter because the fuel flows out. Should it be absolutely necessary to remove it, do it after it has been prepared to prevent the fuel from flowing out by clipping the inside hose.
 - Drain the condensate in container, and then dispose of condensate according to the designated regulations.

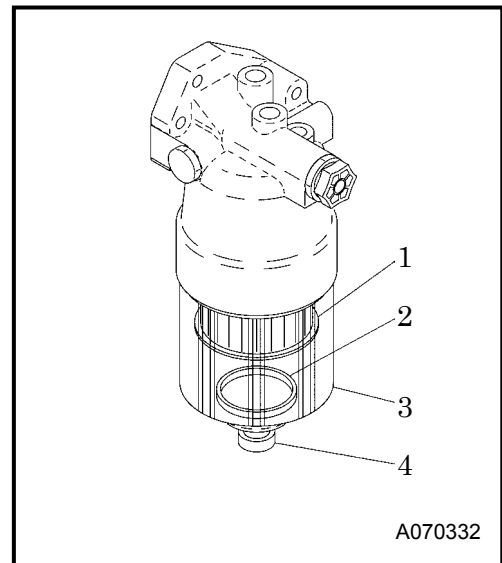

4. Operation

4.5.5 Check fan-belt tension

IMPORTANT

- If fan-belt tension too tight, it can cause shaft breakage or shorten the life of a bearing. If too loose, the belt may slip and will cause early breakage or damage to the belt.

- Adjust the fan belt by the following procedure:
<Procedures>

- ① Unfasten the mounting bolts of the alternator to adjust the alternator.
- ② Visually check the belt for any crack, wear, and other defect.
- ③ Loosen the mounting bolt of alternator once. Then adjust it so that the belt deflection will be 6-8 mm [98.1N (10kgf)] when pressing with a finger.
- ④ Be careful not to leave any grease and LLC on the belt. If any of such material is left, wipe it off completely.

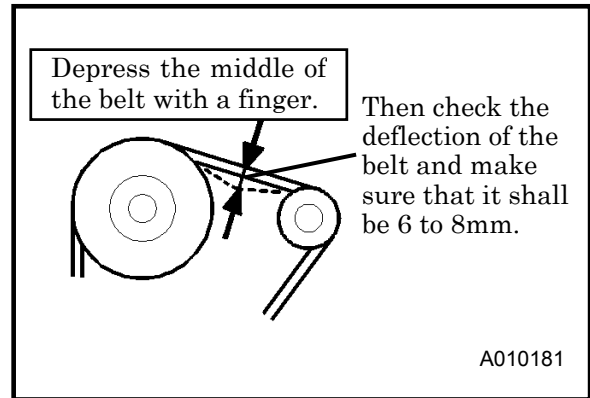

4.5.6 Check condensate in the oil fence

- A drain outlet is provided at the side of the oil fence. Remove the drain plug "1" and drain the condensate accumulated inside the oil fence.
- After making sure that the condensate is drained, install the drain plug "1".
- Drain the condensate in container, and then dispose of condensate according to the designated regulations.

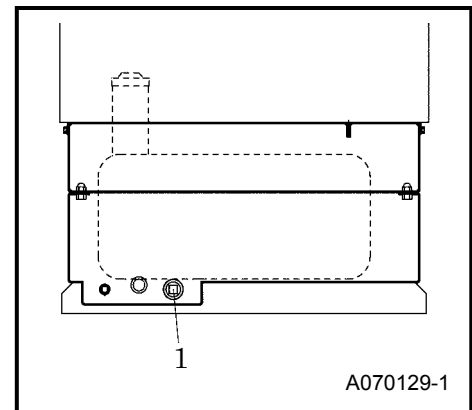

4.5.7 Cleaning the instruments inside control panel

- Before starting operation, open control panel and check each breaker, terminal plate and each controller for any dust, sand and dirt accumulated.
- If the machine is operated with such dust, sand and dirt sticking, it could cause malfunction and trouble of instrumentation. If any, stop the machine, and clean them by blowing compressed air. when doing cleaning job, wear protection glasses.

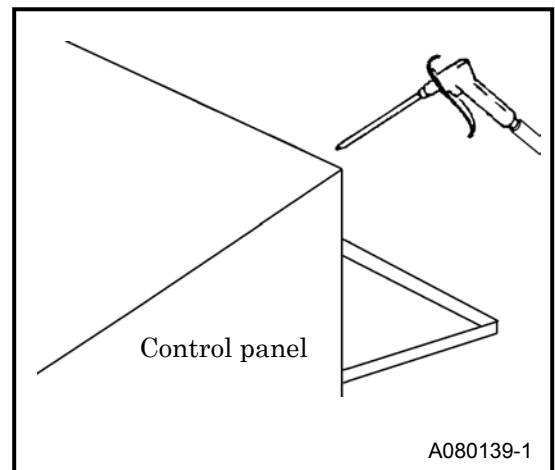

4. Operation

4.6 Unit Operation

WARNING

- Keep the door shut and locked when machine is in operation.
- If opening the door is necessary, be careful not to touch rotating or hot parts. Burns or serious injury could result.

IMPORTANT

- After the engine starts up, warm up it under unload for approx. five minutes.
- Warming up after starting up is necessary for smooth operation of the engine. Do not operate the engine at full load immediately after it starts up. This will shorten the equipment life.
- During the warm-up operation, examine the different parts of the equipment for any looseness, leakage of water, oil, fuel, and other irregularities.
- Also, make sure that the alarm lamps are off.
- Be sure to operate the generator at a rated frequency, irrespective of the load capacity.
If the machine is operated with a frequency lower than the rated frequency, it could cause the generator or to be burned.
- Do not set engine speed except 60Hz by "FREQUENCY ADJUSTER".

4.6.1 Procedure to Start the Unit

Follow the starting procedure below.

<Manual operation>

- ① Switch "OFF" the circuit breaker on the instrument panel.
- ② Set the selector switch "1" to "MANUAL" operation position.
- ③ Turning the starter switch to the "RUN" position, the engine starts preheating automatically.
- ④ When the preheating lamp goes off, turn the starter switch to "START" position and start the engine.
- ⑤ Once engine has started, let it warm up about 5 minutes at no-load condition.
- ⑥ Check frequency of generator at 60Hz. Switch "ENGINE SPEED" switch to "HIGH" position and adjust frequency to 60Hz by "FREQUENCY ADJUSTER" if it is not set at 60Hz.
- ⑦ Adjust the voltage to the rated voltage by turning the voltage regulator knob, watching the voltmeter.
- ⑧ Switch the three-phase breaker "ON" to supply generator power. To use auxiliary AC power receptacles, switch the single-phase and three-phase breakers to "ON" for power.

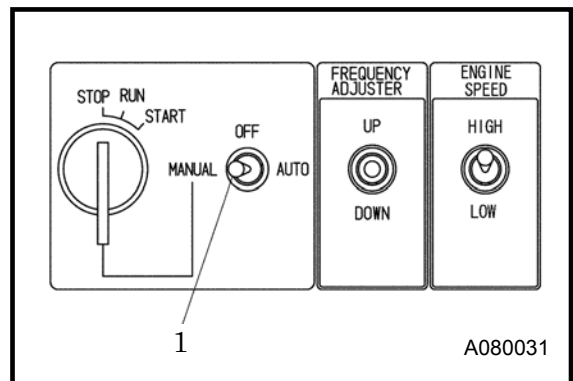

4. Operation

<Automatic operation>



WARNING

Inspection and maintenance prohibited during automatic operation

- Never put your hands close to the interior of the machine, because the generator can be started when start signal functions even while the machine is in stop position.
- Before starting inspection and maintenance job, make sure to place the selector switch of automatic starting panel to “MAN” position and to hang the tag “Under inspection and maintenance”.
- Remove the battery cathode cable terminal.
- Pull out the starter key of the generator and the inspector himself should keep it during inspection and maintenance job. neglect and/or ignoring the above items could cause a serious accident to other persons standing close by the machine when any other person than the inspector himself starts the machine.



1. Cable connection method of remote control switch

The remote control terminal “1” is provided inside the output terminal. Perform cable connection as shown below for remote control operation of the machine. For this cable connection job, make sure to remove the battery cathode cable terminal.

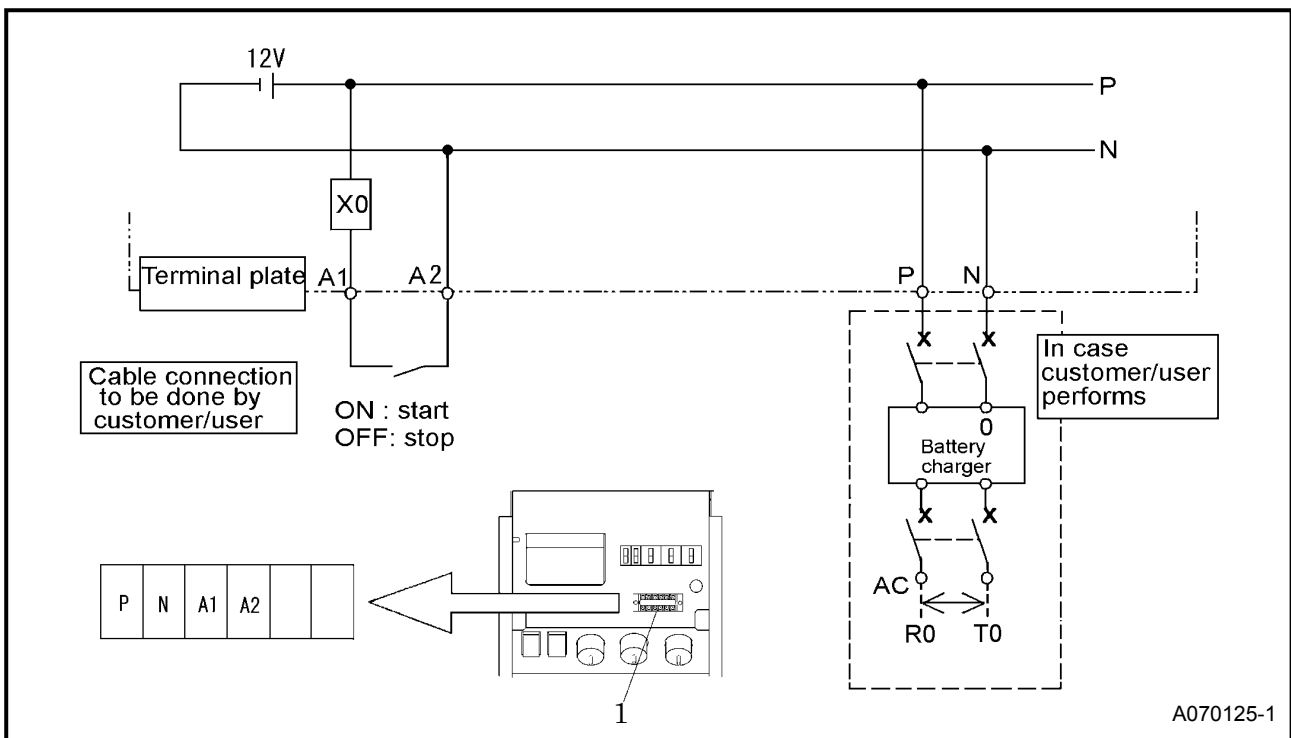

IMPORTANT

Install the battery charger

- While the machine is in stand-by conditions during automatic operation, battery discharge occurs. Make sure to charge battery, operating the battery charger.

4. Operation

2. Operating procedure

- ① Start the generator unit under the procedure of manual operation and adjust the frequency and voltage.
- ② Turn the starter switch to “STOP” position and stop the engine.
- ③ Turn the circuit breaker of output terminal “ON” after the generator unit stopped when you use the circuit breaker and single phase receptacle on the control panel.
- ④ Turn the operating selector switch to “AUTO” position on the control panel, switch “ENGINE SPEED” switch to “HIGH” position.
- ⑤ The unit will be under stand by and start once the start signal is sensed.

3. Function

When start signal activates in stand-by conditions, it starts the generator engine after preheating. When stop signal activates, it continues 5 seconds cooling down operation to stop engine and the machine is placed again in stand-by conditions.

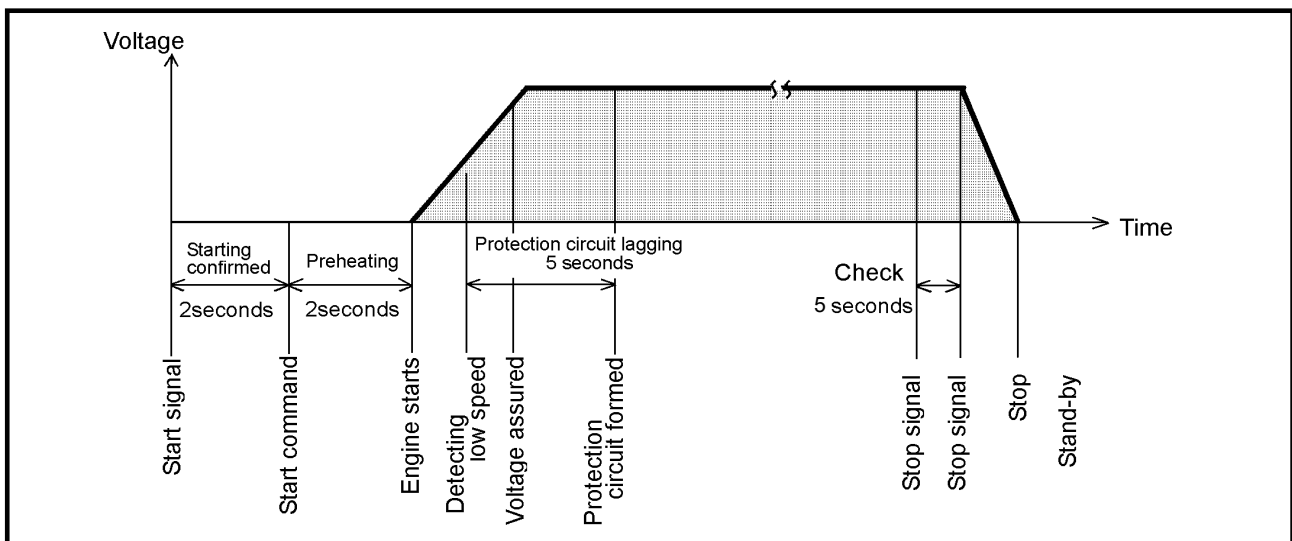

4. Starting action

Even when the engine will not start even after cranking operation for 10 seconds, stop it 8 seconds and then try cranking operation again. In case the engine will not start even after cranking operation is repeated three times, trouble signal goes on showing difficulty in starting.

In case that the lamp “OVERCRANK” goes on, switch off power supply once, pressing the button “EMERGENCY STOP”. Then after releasing the button “EMERGENCY STOP”, get rid of the cause of trouble why engine would not start.

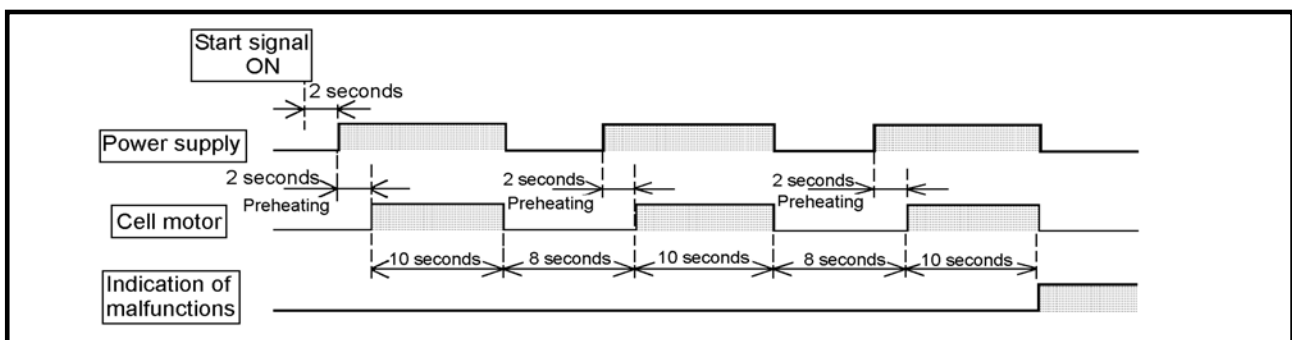

IMPORTANT

Perform periodical inspection and maintenance of the generator

- For maintenance of the generator, try operation 5 to 10 minutes once a week.

4. Operation

CAUTION

- This machine is so designed for safety that operator may not touch the output terminal during operation. If you open the output terminal cover during operation with three-phase breaker switched “ON”, the three-phase breaker will be “OFF” to cut power supply to the output terminal. When starting operation, make sure that the output terminal cover is closed.

4.6.2 Meter and Indicator Lights while Operating

During normal operation, each indication of instruments is shown in the table below. Refer to the table for daily checks.

Note: The values marked ※ vary with location of the voltage selector switch.

	Voltmeter (V)	Frequency meter (Hz)	Ammeter (A)	Monitor lamp							Indicator lamp
				Oil pressure	Engine temp.	Over crank	Air filter	Containment level	Boost temp.	Diagnostic Lamp	Glow
Before Starting up (preheatin	0	0	0	● Off	● Off	● Off	● Off	● Off	● Off	● Off	 On
During Operation	※ 240 480	60	Less than rated current					● Off			● Off

- Be sure to frequently check meters and indicators for proper operation, or any machine water, oil, fuel leaks, etc.
- The above table gives standard values. They may vary slightly depending on operating conditions and other factors.
- In single-phase load operation, check the current of L1, L2, and L3 phase with the ammeter, by turning the ammeter change-over switch. Each current should be balanced if unbalanced. Change load connections so the current of L1, L2, and L3 is equally balanced. Make sure that the current of each phase does not exceed the rated one.
- When the voltage selector switch is in the single-phase 240/120V position, place the ammeter change-over switch to the L1 or L3 position to read the output.

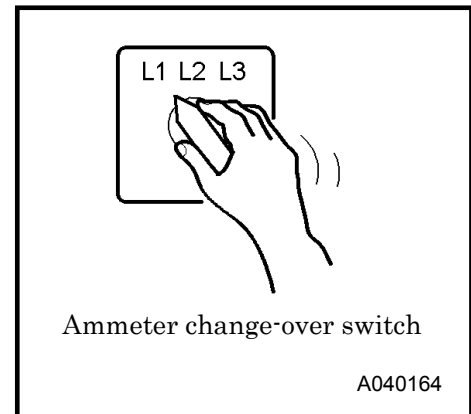

4.7 Stopping Procedures

<Procedure>

- ① Switch “OFF” the breaker on the operation panel of the generator.
- ② After performing cooling down operation about 5 minutes, place the starter switch to the “STOP” position to stop the engine.
- ③ While the machine is kept unused, keep the operation selector switch placed to the “OFF” position.

4. Operation

4.8 Emergency Stop

CAUTION

- The Emergency Stop button should be used only for emergency stop.
- Regularly check the operating performance.

- If it is necessary to stop the generator for emergency, press the Emergency Stop button.

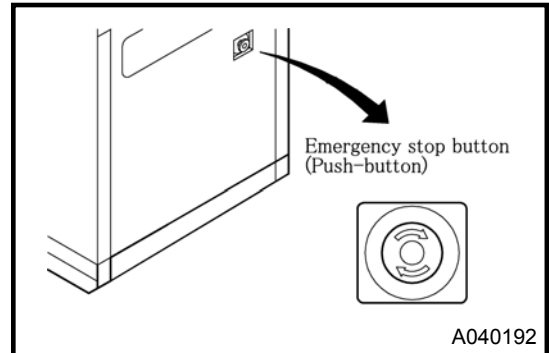

- To reset the button, turn the button head in the direction of the arrow. If it is not reset, the machine cannot restart to operate.

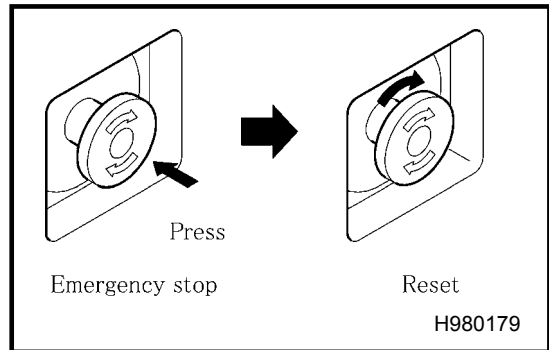

4.9 Air Bleeding

Should the machine stop due to the shortage of fuel, perform the air bleeding operation according to the following procedures.

<Procedure>

- ① Place the operation selector switch to the “MANUAL” position.
- ② Place the starter switch to “RUN” position to put electromagnetic pump into operating conditions.
- ③ Loosen the air bleeding plug of fuel filter so much. Push the priming pump more than 20 times till the fuel comes out.
- ④ Tighten the air bleeding plug and keep pushing the priming pump so that fuel can be filled (more than 10 times)
- ⑤ After waiting about one minute, loosen the air bleeding plug and then remove fuel filter.
- ⑥ Repeat the above ③-⑤ operations till air will not come out (at least more than 3 times.)
- ⑦ Tighten the air bleeding plug firmly and wipe out any trace of split fuel around.
- ⑧ Place the operation mode selection switch to “LOW” position and start engine.
But if engine will not start, try again all operation procedures from above ④.
- ⑨ Keep warming up operation for 3 minutes after engine has started.
- ⑩ Then place the operation mode selection switch to “HIGH” position and raise engine speed up to the rated speed (RPM). Thereafter, repeat mode selection operation “LOW”⇔“HIGH” several times.

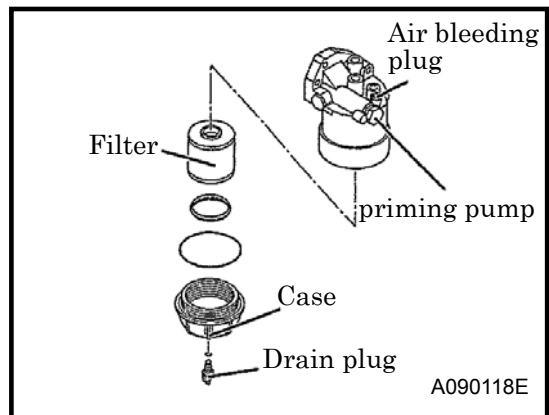

5. Periodic Inspection/Maintenance

5.1 Important Items at Periodic Inspection and Maintenance or after Maintenance

- The manual shows proper interval for periodic inspection and maintenance under normally operating conditions. Inspection and maintenance should be performed more often under extremely harsh conditions.

WARNING

Hang a "Now Checking and under Maintenance" tag

- Remove the starter key from the starter switch before starting inspection, and hang up a "Now Checking and under Maintenance" tag where it can be easily seen. The checker must keep the key during checking and maintenance.
- Remove the negative (-) side cable from the battery. If the above procedure is neglected, and should another person start operating the machine during check or maintenance, it could cause serious injury.
- Be sure to use appropriate tools for inspection and maintenance work. Inappropriate tools could cause unexpected injury.

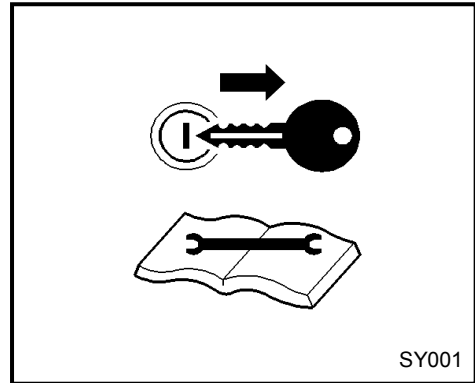

IMPORTANT

Precaution for check and maintenance

- Be sure to use recommended fuel, oil, grease, or antifreeze.
- Do not disassemble or adjust engine, compressor or part(s) for which inspection or maintenance is not referred to in this manual.
- Use genuine parts for replacement.
- Any breakdown, caused by using unapproved parts or by wrong handling, will be out of the scope of "WARRANTY".
- Do not pour water or steam on electrical components.
- Place a container or a pan underneath the oil port to receive waste liquid so that such liquid cannot be spilled out on the floor or inside the machine.
- Be sure that no waste liquid is disposed of on the ground. Such waste on the ground, river or lake will cause serious environmental contamination. Be sure to follow the local regulations. If harmful material such as oil, antifreeze solution or filters are disposed of incorrectly, the responsible person should be punished by the authority.
- Observe local regulations when disposing of such toxic materials as oil, fuel, coolant (anti-freeze), filters, and battery etc.

5. Periodic Inspection/Maintenance

5.2 Daily Inspection and Keeping Operation Log

- Be sure to carry out daily inspection every morning before operation. See Chapter 4 “OPERATION” of the manual for the details of inspection.
- Pay attention to and carefully observe the following points during daily operation or inspection and maintenance work. If any trouble or abnormality is found, immediately investigate its cause and make repairs. If the cause is unknown or not traceable, or if the trouble involves a part or component not described in the manual, ask your nearest dealer for information.
 - (a) Controls and instruments function properly.
 - (b) Quantity and any leak of water, fuel, and oil or any contamination should be checked.
 - (c) Appearance, abnormal noise or excessive heat should be checked.
 - (d) Loose bolt or nut should be checked.
 - (e) Any damage, wear or shortage of machine components and parts should be checked.
 - (f) Performance of each part or component should be proper.
- Keep the operation log to record constant inspection of each component, so that trouble of the machine can be easily discovered and preventive measures can be taken.

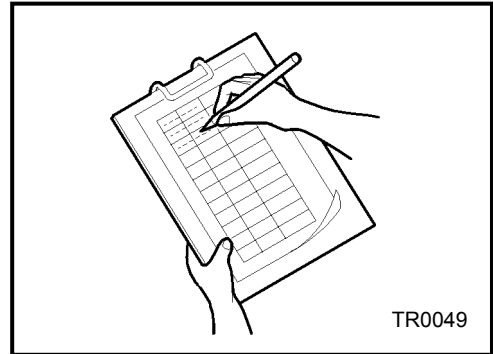

It is very useful to record information such as frequency, temperature, current, maintenance items and replenishment of lubricant on a daily maintenance log.

5.3 Periodic Replacement of Parts

IMPORTANT

Use our genuine elements

- Air filter is a crucial component for the performance and the life of a unit. Use genuine part for replacement.
- Part number changes upon modification. For replacement of parts, make sure whether the part number is correct or applicable.

Part Name	Part Number		Quantity
	SDG45S-8B1	SDG65S-8B1	
Air filter element	32143 11800	32143 11800	1
Engine oil filter element kit	ISUZU 898018-8580	ISUZU 898018-8580	1
Fuel filter element kit	ISUZU 8980088400	ISUZU 8980088400	1
Fuel pre-filter element kit	ISUZU 8980758540	ISUZU 8980758540	1
Fan-belt	ISUZU 8980388560	ISUZU 8980388560	1
Electromagnetic pump filter	ISUZU 8980714010	ISUZU 8980714010	1

5. Periodic Inspection/Maintenance

5.4 Periodic Inspection List

Such items marked ○ shall be carried out by customers.

For the following items or clauses marked ●, contact us directly or our distributors because they require expert technical knowledge on them.

The following table shows the intervals of inspection and maintenance under normal operation conditions. Inspection and maintenance should be done at either of the hour or the period mentioned in the remarks column, whichever comes earlier.

* Refer to engine operation manual for inspection and maintenance of an engine.

Maintenance		Daily	Every 50 hours	Every 250 hours	Every 500 hours	Every 1,000 hours	Page	Remarks
Generator	Cleaning instruments in control panel	○					4-12	Cleaning should be done when needed.
	Check each instrument and warning lamp	○					4-16	
	Check insulation resistance			○			5-7	Every 4 months
	Check GFCI receptacles			○			5-6	Every monthiy
	How to check thermal relay			○			5-7	
Engine	Check fuel	○					4-11	
	Check engine oil level	○					4-10	
	Check coolant level	○					4-10	
	Check fan-belt tension	○					4-12	In the case of NG, it exchanges.
	Check fuel pre-filter drain.	○					4-11	
	Check and Clean clogging of air filter element			○			5-8	Perform cleaning when the monitor lamp glows.
	Drain fuel tank.			○			5-8	
	Change engine oil		○ (First time)		○		5-5	
	Change engine oil filter		○ (First time)		○		5-6	
	Check battery electrolyte.			○			5-8	
	Check Specific gravity of battery electrolyte.				○		5-8	
	Change fuel filter and fuel pre-filter				○		5-9	
	Clean outside of radiator and Intercooler				○		5-9	Dirt condition cleans.
	Drain condensate out of intercooler.				○		5-10	
	Check for crack and leak on the exhaust flexible pipe				○		5-10	Every 4 months
	Clean and change filter inside the fuel air bleeding electromagnetic pump.					○	5-11	
	Change air filter element					○	5-14	
	Change coolant (LLC)					○	5-13	Every 2 years
	Check engine valve clearance					●		
	Adjust fuel injection nozzle					●		
Check fuel injection timing					●			
Clean inside the radiator.					●			

5. Periodic Inspection/Maintenance

Maintenance		Daily	Every 50 hours	Every 250 hours	Every 500 hours	Every 1,000 hours	Page	Remarks
Others	Check condensate in the oil fence	○					4-12	
	Check the terminal portion of electrical circuits and cable connections				○		5-11	Every 4 months
	Clean inside of the oil fence and check it for any rust					○	5-12	Yearly
	Check vibration isolator rubbers					○	5-14	Yearly
	Check each rubber hose					○	5-14	Yearly

Note: The above intervals of inspection and maintenance are respectively based on the operation time of 125 hours of used per month and of 1,500 hours of use per year.

5. Periodic Inspection/Maintenance

5.5 Maintenance

5.5.1 Change engine oil

[At 50 hours for the first change and every 500 hours thereafter]

CAUTION

Caution in filling or draining engine oil

- When checking, replenishing, and draining the engine oil, be sure to wait 10 to 20 minutes after engine stops until it cools down.
- Engine oil is very hot and highly pressurized during or just after the operation. Hot oil could blow out and can cause injury.



<Procedure>

- ① Loosen the drain plug “1” located outside the frame to drain the oil. Open the drain valve “2” provided inside the machine to drain condensate.
- ② After finishing drainage, close the drain valve “2” securely and install the plug “1” and supply engine oil through oil filler port “3” .
- ③ After finishing the oil supply, tighten the cap of oil filter port “3” firmly.

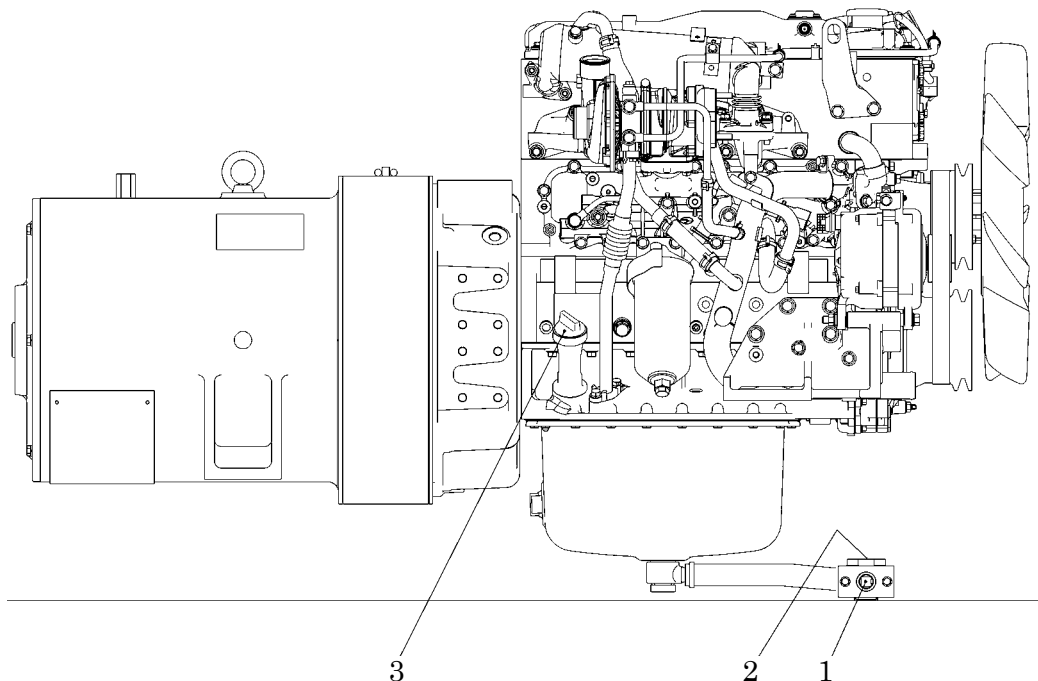

SDG65S-8B1

A080546

5. Periodic Inspection/Maintenance

5.5.2 Change engine oil filter

[At 50 hours for the first change and every 500 hours thereafter]

<Procedure>

- ① Remove drain plug “1” and drain the oil condensed in filter case “2” .
 - ② Remove filter case “2” by loosening center bolt “3” and pull out element “4” .
 - ③ Replace all the O-rings “5”, “6” and “7” with new ones (which are used for filter case “2” , center bolt “3” and drain plug “1” .) Then install a new filter element in the filter case “2” .
 - ④ Thinly coat O-ring “5” with engine oil and install filter case “2” by screwing in bolt “3” .
- Both tightening torques for bolt “3” and plug “1” are mentioned below.

Tightening torque for bolt : 44.1N · m

Tightening torque for drain plug: 24.5N · m

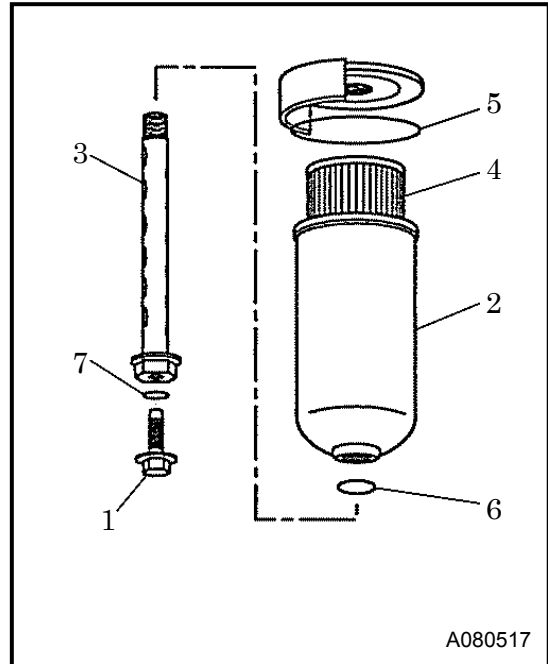

5.5.3 Check GFCI receptacles

[Monthly or 250 hours operation, whichever comes first.]

WARNING

- If the generator is stored outdoors, unprotected from the weather, test the GFCI receptacle before each use.
- In case the GFCI has tripped due to the hazard of ground fault currents, investigate the cause and correct it.

Regularly check the GFCI operation for safety.

<Procedure>

- ① Unplug all appliances from the generator.
 - ② Start the engine.
 - ③ Turn each single-phase and three-phase breaker ON.
 - ④ Press the TEST BUTTON
- The RESET BUTTON should extend with a click.
 - If the RESET BUTTON does not extend, contact your nearest dealer.
- ⑤ Press the RESET BUTTON
 - ⑥ When the RESET BUTTON extends during peration.
- Unplug all appliances from the GFCI protected receptacle.
 - Press the RESET BUTTON:

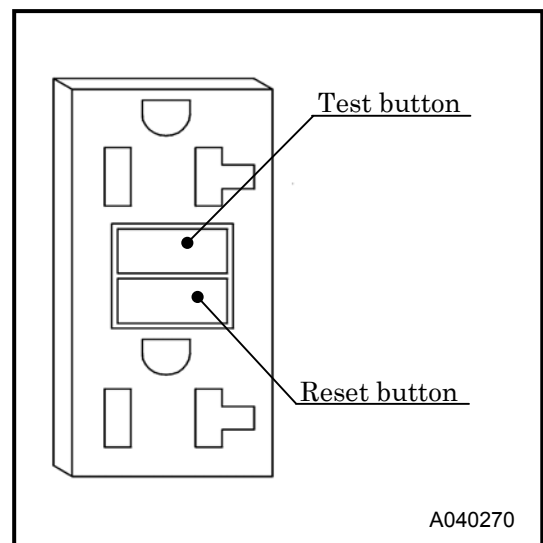

IF THE GFCI CANNOT BE RESET: The GFCI is faulty. Contact your nearest dealer.

IF THE GFCI RESETS PROPERLY: Check the appliance or the power cord.

5. Periodic Inspection/Maintenance

5.5.4 Check Insulation resistance

[Every 250 hours]

IMPORTANT

- When the generator has not been operated for a long time or moisture has entered inside the machine, be sure to measure the insulation resistance. If resistance is lower than $1M\Omega$, it could cause an electrical leakage or fire. Dry the generator with compressed air until the resistance exceeds $1M\Omega$ prior to operating.
- Since the generator insulation may drop when moisture, oil vapor, and dust are stuck, always keep the machine clean.

<Procedure> <Megger tester required>

- ① Remove the load side cable from the output terminal board.
- ② Remove the cable between the terminal "N" and terminal "Ground" which are connected on the back of the output terminal plate.
- ③ Remove the AVR connector inside the generator control panel.
- ④ Switch ON the three-phase breaker, measure each insulation resistance between the terminals L1, L2, L3 terminal and bonnet.
- ⑤ Insulation resistance when measured with a 500 V megger tester must be above $1M\Omega$.
- ⑥ After finishing the measurement of insulation resistance, re-connect the cable between the terminal "N" and terminal "Ground".

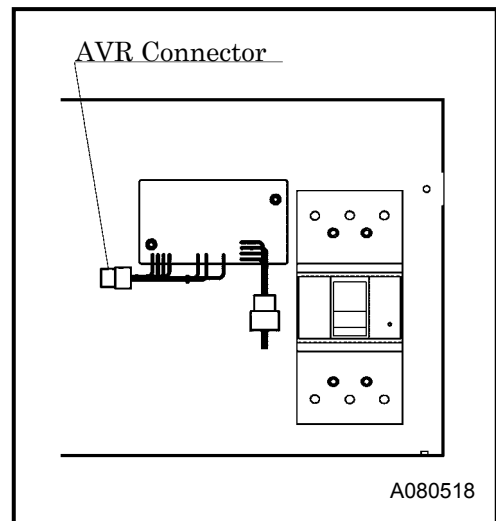
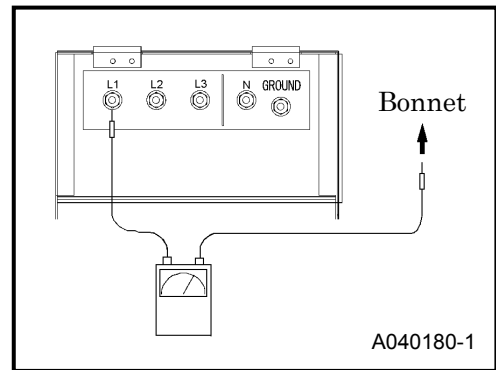

WARNING

- After making sure that the insulation resistance of the generator is higher than $1M\Omega$, be sure to re-connect the cable between the terminal "N" and terminal "Ground" just as it was originally connected. If it is left disconnected, the grounding becomes imperfect so that it could cause electric shock.

5.5.5 How to check thermal relay

[Every 250 hours]

<Procedure>

- ① Turn the starter switch to ON.
- ② Set the main breaker to ON.
- ③ The three phase main breaker will trip if you push the test lever of the thermal relay in the arrow direction.
- ④ Note that once the three phase main breaker trips to the off position, the single phase breaker that supplies power to the GFCI outlets can still be ON.

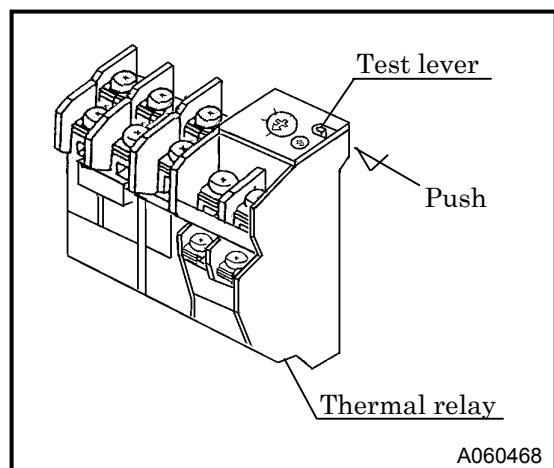

5. Periodic Inspection/Maintenance

5.5.6 Check and Clean clogging of air filter element

[Every 250 hours]

IMPORTANT

Be sure to properly clean air filter element

- When an element that is clogged or has holes or cracks is used, dust or foreign material will get in the engine. This causes accelerated wear in each sliding part of the engine. Be sure to make daily check and cleaning so that the life of the engine will not be shortened.

- When the air filter monitor lamp glows, clean the air filter.

<Procedure>

- ① After removing the cap "1" by loosening its latch "2", clean its interior properly.
- ② Remove the element "3", and clean it.
- ③ When installing the cap "1" after finishing the cleaning job, push the element into the case "4" surely by hand, and then make sure that the latch "2" fixing the cap surely hooks the case "4". Finally tighten it.
- ④ If the element is found heavily dusty, replace it with a new one. (See 5.3)

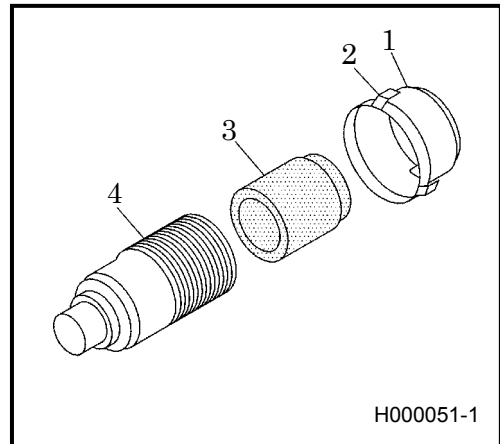

5.5.7 Drain fuel tank

[Every 250 hours]

- Drain the condensate accumulated in the fuel tank "1" by removing the drain plug "2".
- After making sure that the condensate is completely drained, install the drain plug "2" firmly.
- Drain the condensate in container, and then dispose of condensate according to the designated regulations.

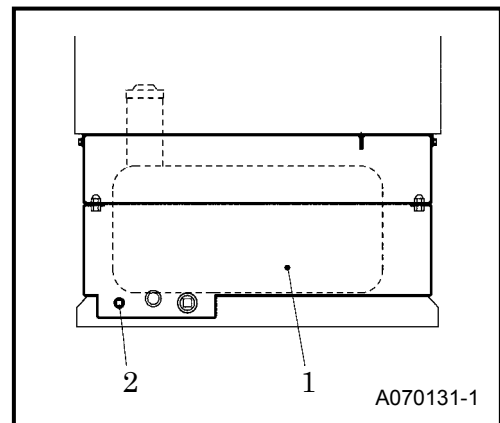

5.5.8 Check Battery electrolyte and specific gravity of battery electrolyte

- Battery electrolyte : every 250 hours
- Specific gravity of battery electrolyte : every 500 hours

If there to be a problem in starting an engine due to a flat battery, carry out the checks by following the procedures below:

1. Ordinary type battery:

Measure specific gravity of battery electrolyte, and if it shows below 1.24, recharge the battery immediately. (See 6.1)

2. Enclosed type battery:

Check the indicator on top surface of the battery.

If the indicator shows that charge is needed, recharge the battery immediately.

5. Periodic Inspection/Maintenance

5.5.9 Change fuel filter and fuel pre-filter

[Every 500 hours]

<Procedure>

- ① Remove the lower case "1", using a filter wrench.
 - ② After coating fuel on the new element "2" packing "3", screw it in. (See 5.3)
 - ③ When the packing "3" touches the seal face, tighten it using a filter wrench.
 - ④ Bleed the air of fuel. (See 4.9)
 - ⑤ After installing a fuel filter, check for fuel leakage during operation.
- For details, refer to engine operation manual.

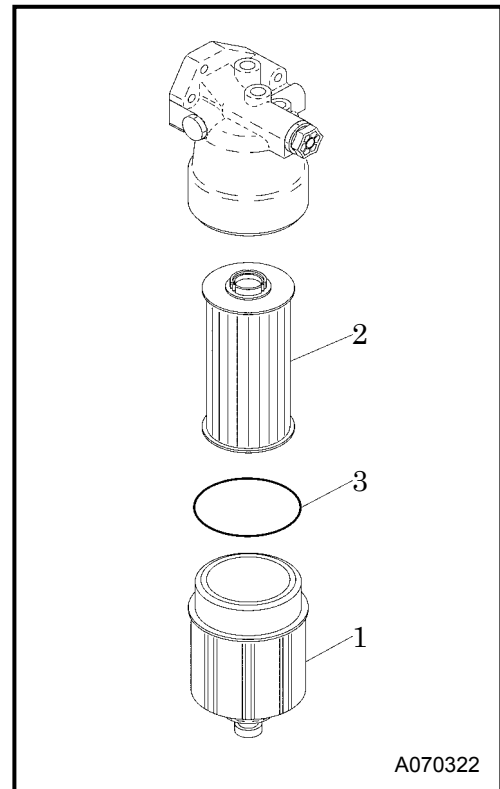

5.5.10 Clean outside of radiator and intercooler

[Every 500 hours]

- When the fin tubes "3" of radiator "1" and intercooler "2" are clogged by dust or other foreign materials, the heat exchange efficiency drops and this will raise coolant temperature. These tubes and fins should be cleaned depending on the state of dirt inside the tubes even before maintenance schedule.
- Do not use high pressure washer for washing to prevent fin tubes "3" from being damaged.
- When the unit is used, installed near seaside and on boat board, clean the radiator using fresh water more times than once a month.

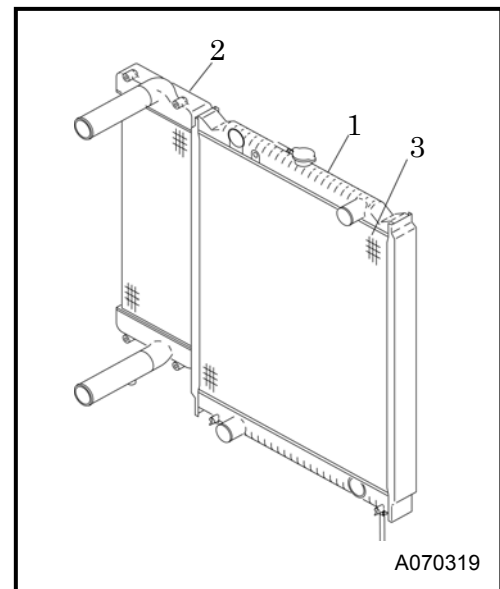

5. Periodic Inspection/Maintenance

5.5.11 Drain condensate out of intercooler

[Every 500 hours]

- Remove the pipe plug “1” provided under the intercooler, and drain condensate.

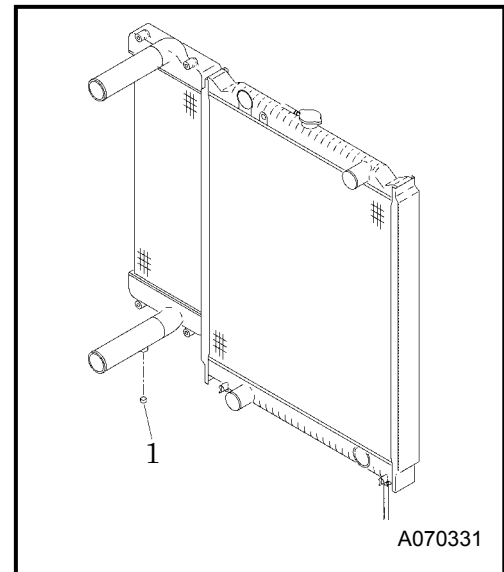

5.5.12 Check for crack and leak on the exhaust flexible pipe

[Every 4 months or every 500 hours]

- Check for any crack and gas leak on the flexible pipe and exhaust between flexible pipe between engine exhaust outlet and the flexible pipe.
- If any leak is found, avoid getting burned by the exhaust gas.

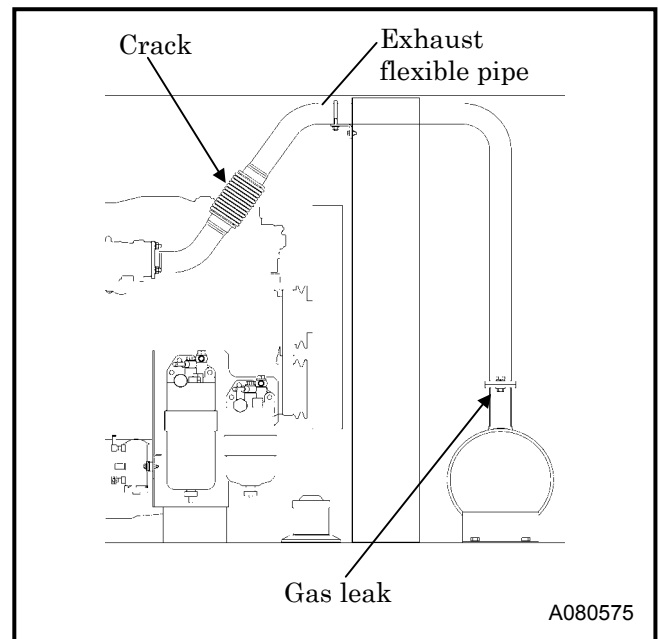

5. Periodic Inspection/Maintenance

5.5.13 Check the terminal portion of electrical circuits and cable connections

[Every 4 months or every 500 hours]

Check for any looseness on the cables and any damages on insulated covers and disconnection, disconnected cables, or short-circuit etc.

[Checking points of electrical circuits on the generator side]

- Terminal connection of three-phase output terminal plate.
- Main circuit of circuit breaker.
- Terminal connection on control box.
- Each terminal connection of each instrument.

[Checking points of electrical circuits on the engine side]

- Portion of connectors to the engine.
- Check for looseness of terminal connections.

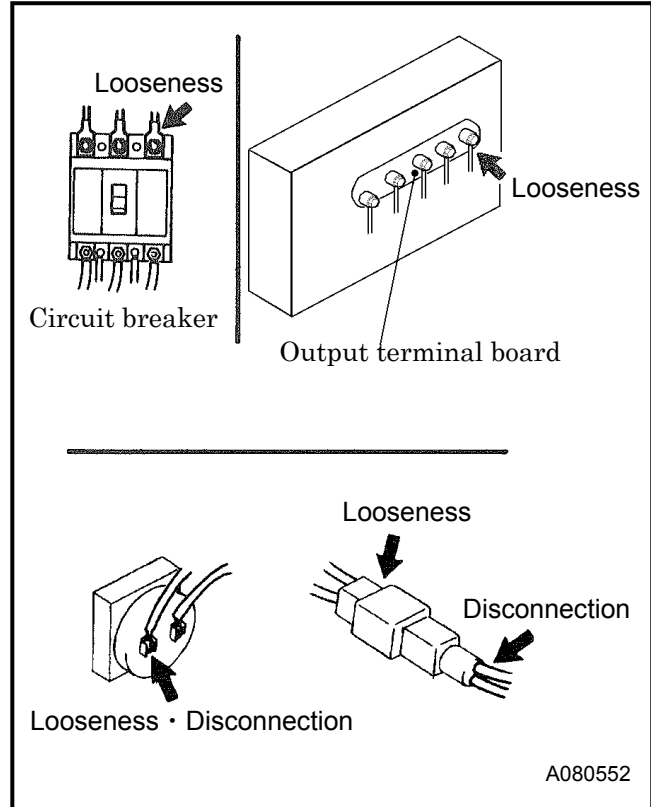

5.5.14 Clean and Change filter inside the fuel air bleeding electromagnetic pump

[Every 1,000 hours]

<Procedure>

- Remove the cap "1" by turning it counterclockwise. Then replace the filter "2" provided in it. (See 5.3)
- When doing this replacement, the fuel inside the filter can flow out. So place a fuel receiver under the filter beforehand.

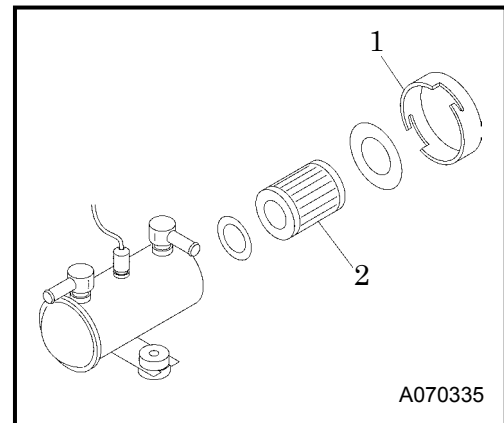

5. Periodic Inspection/Maintenance

5.5.15 Clean inside of the oil fence and check it for any rust

[Every 1 years]

<Procedure>

- ① Remove the oil filler cap cover, fuel pipes and electric wire connected to the fuel tank.
- ② Remove 6 pieces of the bolts connecting oil fence and the machine with the lifting eye hooked with the crane.
- ③ Lift up the machine to separate the oil fence from the machine.
- ④ Check and clean the inside of the oil fence.
 - Check the inside of the oil fence for dust, fur and other foreign matter and check it for any rust.
 - When the oil fence is found rusted, remove the rust outside and inside and paint it again.
 - Should any leakage be found, contact your dealer or us directly.
- ⑤ Check whether the seal rubber attached on the top of oil fence is slanted or curved.
- ⑥ Combining this machine and the oil fence, tighten the nuts 6 pieces.
- ⑦ Install oil filler cap cover, fuel pipes and also electric wires.

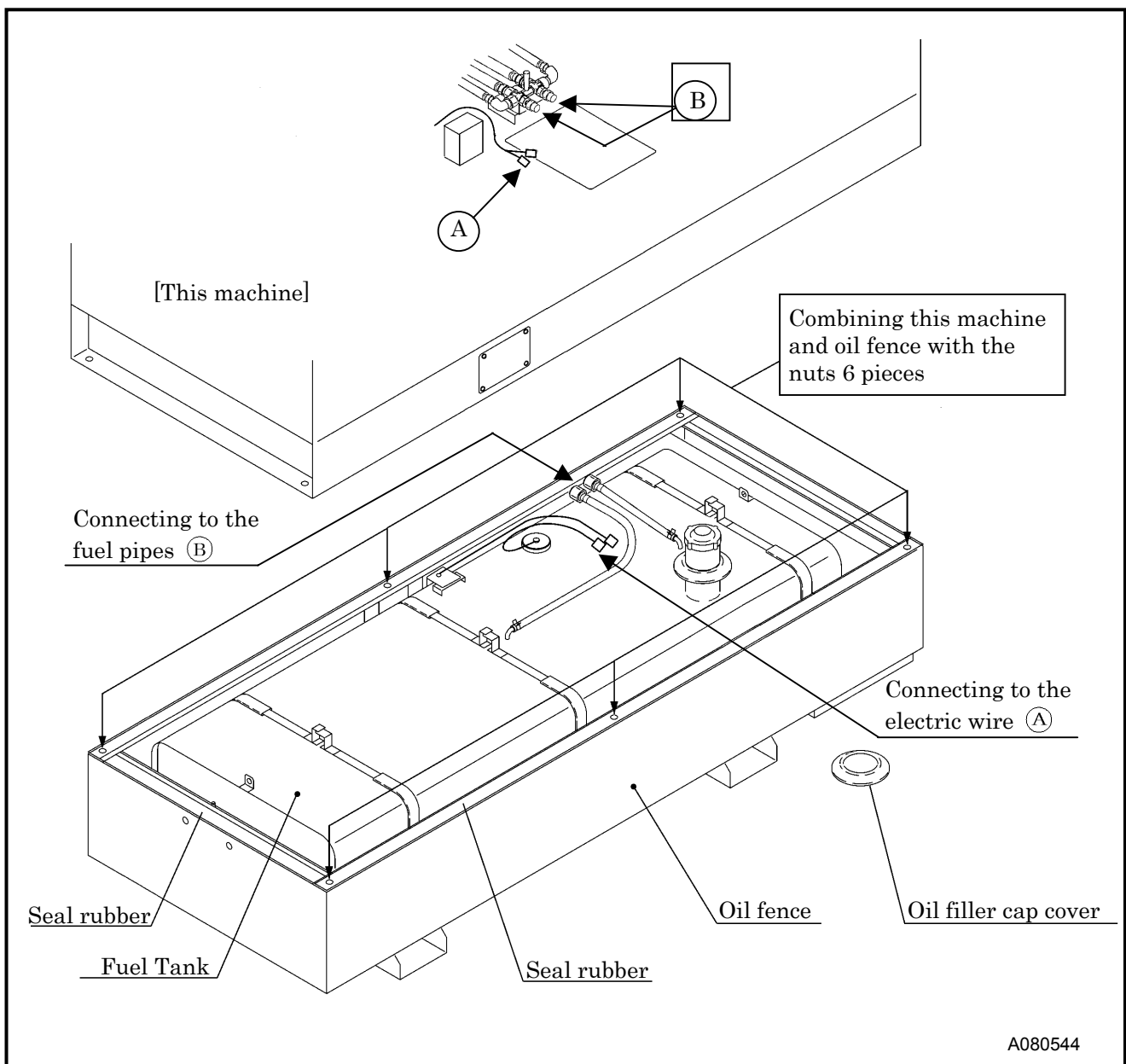

A080544

5. Periodic Inspection/Maintenance

5.5.16 Change Coolant

[1,000 hours or every 2 years]

CAUTION

- Be sure to stop the machine and loosen the radiator cap slowly, after the coolant water is sufficiently cooled and the inner pressure is released, then take the cap off.
If the following procedures are neglected, the radiator cap could be blown by the internal pressure or hot moisture air be blown out to cause burning. Therefore, make sure to carry out them without fail.
- LLC (Antifreeze) is a toxic material.
- When a person has drunk LLC (Antifreeze) by accident, make him vomit and make him see a doctor immediately.
- When a person gets LLC (Antifreeze) in his eyes, wash the eyes with clean running water and make him see a doctor immediately.
- When LLC (Antifreeze) is stored, put it in a container with an indication saying "LLC (Antifreeze) inside" and seal it up, then Keep it in a place away from children.
- Beware of flames.

Upon changing coolant

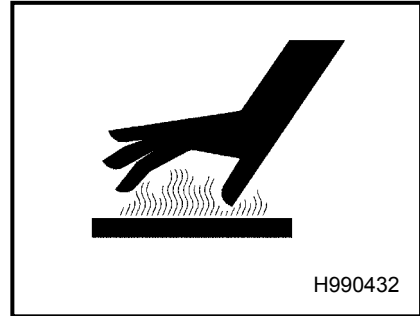

<Procedure>

- ① To drain coolant, remove the radiator cap "1", then loosen the drain valve "2".
 - ② Be sure to also unfasten the drain plug "3" on the engine cylinder block for drainage.
 - ③ When the coolant is completely drained out, close each drain valve "2" and drain plug "3", and supply new coolant from the filler port of radiator "4".
 - ④ After changing the coolant, run the engine under unload operation for 2 to 3 minutes, then stop it. Check the coolant level again and replenish it if necessary.
- For details, refer to engine operation manual.

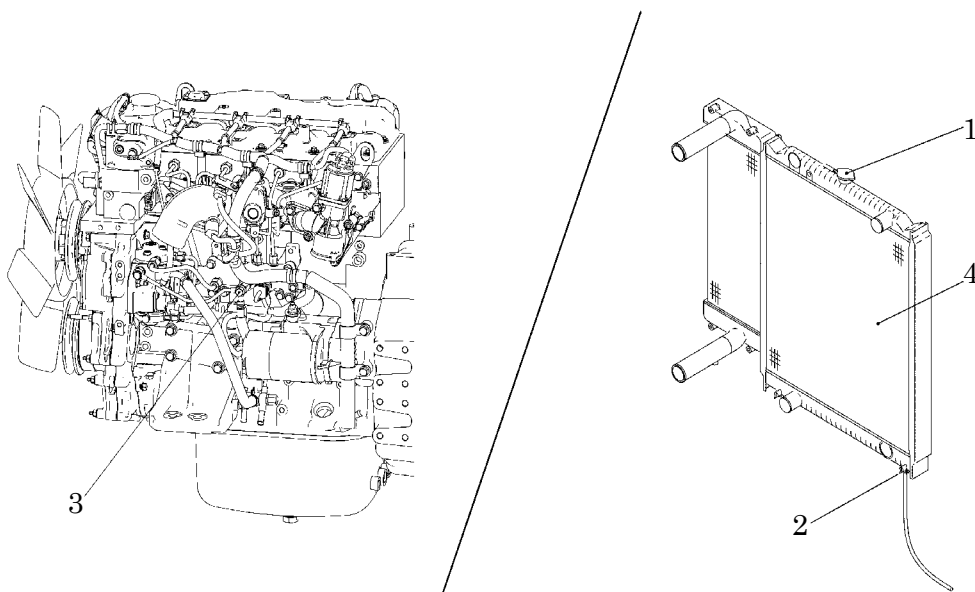

SDG65S-8B1

A080549

5. Periodic Inspection/Maintenance

5.5.17 Change air filter element

[Every 1,000 hours]

IMPORTANT

Be sure to properly clean air filter element

- When an element that is clogged or has holes or cracks is used, dust or foreign material will get in the engine. This causes accelerated wear in each sliding part of the engine. Be sure to make daily check and cleaning so that the life of the engine will not be shortened.

<Procedure>

- ① After removing the cap “1” by loosening its latch “2”, clean its interior properly.
- ② Remove the element “3” and then replace it with a new one. (See 5.3)
- ③ When installing the cap “1” after replacing it, properly push the element into the case “4” by hand and then make sure that the hooks for fixing the cap are surely set. Finally tighten it.

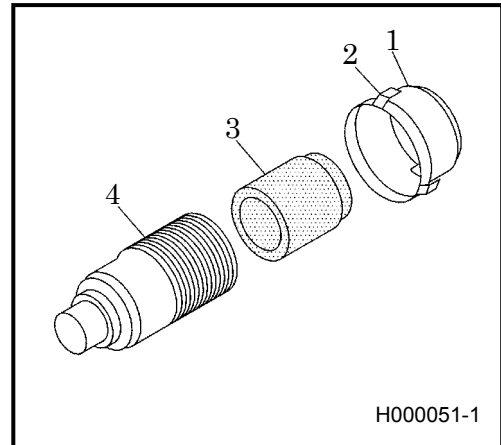

5.5.18 Check vibration isolator rubbers

[Every 1 year or every 1,000 hours]

- The vibration isolation rubber “1” is used for the support of generator and engine. Check the rubber for any damage or deterioration due to oil sticking.

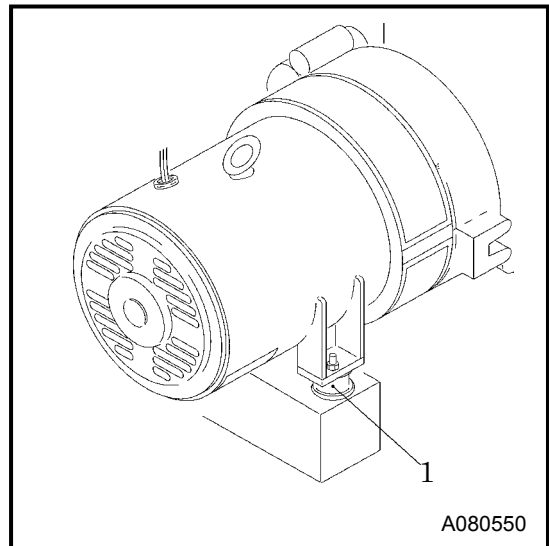

5.5.19 Check each rubber hose

[Every 1 year or every 1,000 hours]

Check all the rubber hoses for being hardened, crack and fissure.

- If any hardening, crack or fissures are found on each hose (air filter, radiator, fuel and drain) replace it by a new one.
- Check each clip fixing the hoses and if any loosened hose is found, retighten it.
- Even before the periodical internal comes, replace it if any hardening, any cracks are found. When replacing it, please contact our branch office or your distributor.

6. Maintenance/Adjustment

6.1 Maintenance of Battery

DANGER

- Keep flames away from battery.
- Battery may generate hydrogen gas and may explode.
- Therefore, recharging should be done at a well-ventilated place.
- Do not spark near the battery nor light a match, nor bring lit cigarette and match close to the battery.
- Do not check the battery by short-circuiting the positive and negative terminals with a metallic piece.
- Never operate the machine nor charge the batteries with the battery liquid level being kept lower than the “LOWER” level. Continuing operation at this lower level will cause deterioration of such parts as pole plates etc., and also it may cause explosion as well as reduction of battery life.
Add distilled water so that the liquid level may reach the middle level between the “UPPER” and “LOWER” level without any delay.
- Do not charge the frozen battery. Otherwise it may explode. If the battery is frozen, warm it up until the battery temperature becomes 16°C to 30°C.
- Battery electrolyte is dilute sulfuric acid.
In case of mishandling, it could cause skin burning.
- Wear protective gloves and safety glasses when handling a battery.
- When such battery electrolyte contacts your clothes or skin, wash it away with large amount of water immediately.
- If the battery electrolyte gets into your eyes, wash it away immediately with plenty of water and see a doctor at once, because it is feared that eyesight might be lost.
- Dispose of battery, observing local regulations.

Handling battery



D004

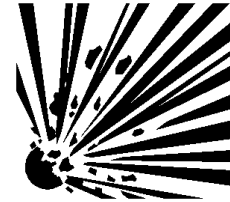

W010



TR0093

CAUTION

Reverse connection prohibited

- Never reverse the cable connections. — When a booster-cable is unavoidably used or when a set of cables is connected after a battery change, be sure to correctly connect the electric terminals (+) and (-). Reversely-connected cables will cause sparks or damage to components.

6. Maintenance/Adjustment

6.1.1 Charge Battery

- Disconnect the cable between battery and the unit, and charge the battery with a 12 V battery charger. Do not charge two batteries at the same time.
- Be sure not to connect (+) and (-) terminals backwards.
- Be sure to read the operation manual of the battery charger to know if it is applicable, before using it.

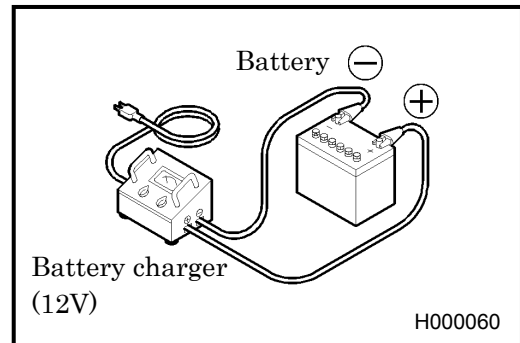

6.1.2 How to Use Booster Cable



CAUTION

Do not reverse the cable connection

- When a booster cable has to be used or when cables are connected again after an battery is replaced, be careful not to connect (+) and (-) terminals backwards. Such wrong-connection will cause spark and damage to each component.

<Procedure for using a booster cable>

- ① Stop the engine.
- ② Connect one end of the (+) cable to the (+) terminal of the machine battery.
- ③ Connect the other end of the (+) cable to the (+) terminal of the external battery.
- ④ Connect one end of the (-) cable to the (-) terminal of the external battery.
- ⑤ Connect the other end of the (-) cable to the engine block of the machine.
- ⑥ Start up the engine.
- ⑦ Disconnect the booster cable by following the procedure back in the reverse order.

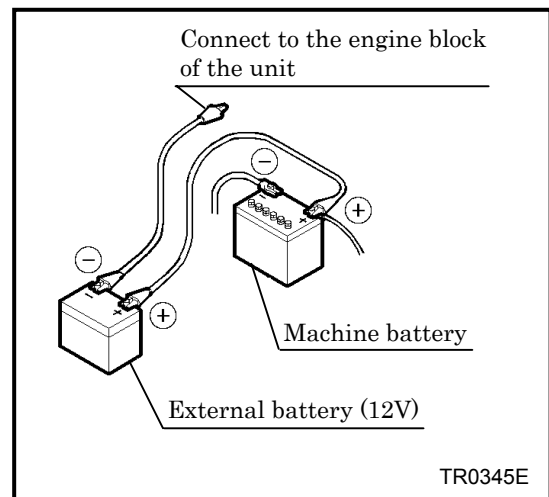

6. Maintenance/Adjustment

6.2 Troubleshooting

- Should any trouble occur during operation, do not leave it. Investigate the cause and take appropriate measures.
- Read the manual carefully and fully understand what to do in case of trouble.
- The better you understand the construction and function of the unit, the faster you can find a problem and solution.
- This chapter describes the state, cause and countermeasures of important troubles in detail:
- When “DIAGNOSTIC LAMP” turn on, push “DIAGNOSTIC BUTTON” and check “FAULT CODE”. See “OPERATOR’S MAUAL” and research the cause of trouble.

Symptom	Cause	Counter measures
Starter does not rotate. Low starter revolution speed even when starting.	(1)Battery malfunction	Check Battery→Charge/Change
Starter rotates but engine does not start up.	(1)Fuel filter clogging (2)Fuel pre-filter clogging (3)No diesel fuel oil (4)Air mixing in fuel pipings	Disassemble, clean, and change Disassemble, clean, and change Replenish fuel Bleed air
Engine oil pressure drop monitor lamp glows.	(1)Engine oil shortage (2)Engine oil filter clogging (3)Oil pressure switch malfunction (4)Loosened or disconnected wiring, or connector	Replenish fuel Change Change Check/repair
Coolant temperature rise monitor lamp glows.	(1)Radiator clogging (2)Faulty thermostat (3)Faulty coolant temperature switch (4)Shortage of coolant (5)Slip of fan belt (6)Looseness, disconnection of wiring or connectors	Clean Change Change Replenish Adjust tension Check/repair
Leakage relay lamp glows.	(1)Leakage on generator side (2)Leakage on load side (3)Leakage on connecting cable (4)Defective leakage relay	Check/repair Check/repair Check/repair Check/repair
The monitor lamp for air filter clogging flickers.	(1)Air filter clogging	Clean
Oil fence monitor lamp glows.	(1)The condensate (fuel, engine oil and coolant) is accumulated in the oil fence. (2)The liquid surface level detecting switch does not function good.	Drain the condensate. Check/change

6. Maintenance/Adjustment

Symptom	Cause	Counter measures
Even when operated at a rated speed, no voltage or too low voltage generated.	(1) Faulty voltmeter (2) Poor tightening of terminals (3) Broken or short-circuited winding of generator main unit (4) Faulty AVR (5) Faulty silicon rectifier (mounted on generator rotor) (6) Faulty exciter (7) Broken or short-circuited circuit to exciter field winding (8) AVR frequency selection switch is not set to meet the frequency to be operated. (9) Function circuit protector (CP) for AVR protection	Check/change Check/repair Check/repair Check/change Check/change Check/repair Check/repair Check/select Reset
Too high voltage generated when set at the rated frequency (50Hz/60Hz), Voltage will not drop even when the voltage regulator controlling knob is turned.	(1) Loosened or disconnected wiring, or connector to AVR (2) Faulty AVR (3) Broken wire or poor contact of AVR variable resistor	Check/repair Check/change Repair or change
Unstable voltage generation	(1) Poor tightening of each terminal (2) Faulty AVR (3) Function circuit protector (CP) for AVR protection	Check/repair Check/change Reset

- Please contact your nearest dealer if you find it difficult to repair by yourselves.
- Please refer to the engine operation manual for troubles concerning the engine.

6. Maintenance/Adjustment

6.2.1 Engine trouble

- This unit is equipped with a device of controller which memorizes contents of engine trouble. When engine fails, trouble diagnosis lamp “1” goes on. For the details of the trouble, press trouble diagnosis switch “2” and then it displays the conditions of the failure, lamp blinking.

<Procedures>

- ① Turning starter switch to “RUN” position, keep pressing trouble diagnosis switch “2”.
 - ② In case that any trouble is found while it is kept pressing, trouble diagnosis lamp “1” displays the details of the failure by lamp lighting.
- To solve or repair failures, special knowledge is required. Contact your nearest distributor or directly us.

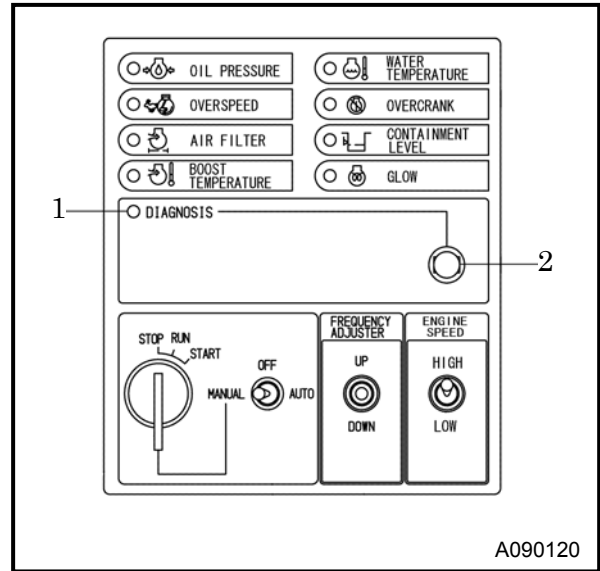

[Example of diagnosis lamp lighting]

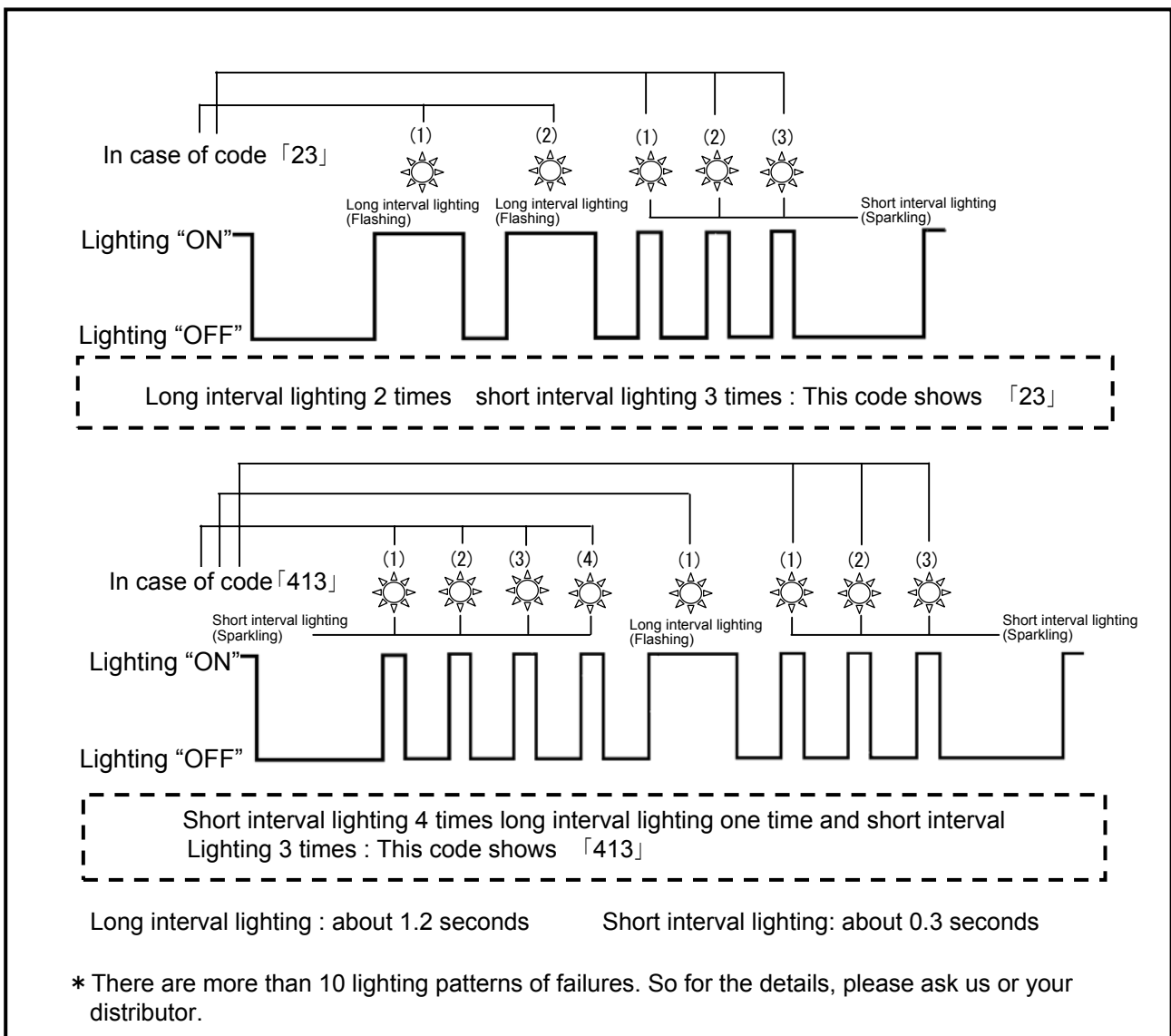

7. Storage of the Unit

7.1 Preparation for Long-term Storage

When the unit is left unused or not operated longer than half a year (6 months), store it at the dry place where no dust exists after the following treatments have been done to it.

- Put the unit in a temporary cabin if it is stored outside. Avoid leaving the unit outside with a sheet cover directly on the paint for a long time, or this will cause rust to the unit.
- Perform the following treatments at least once every three months.

<Procedure>

- ① Discharge existing lubricant from the engine oil pan. Pour new lubricant in the engine to clean its inside. After running it for a while, drain it again.
- ② Spread lubricant on each moving part.
- ③ Completely charge the battery and disconnect grounding wires. Remove the battery from the unit, if possible, and store it in a dry place. (Charge the battery at least once every month.)
- ④ Discharge coolant and fuel from the unit.
- ⑤ Seal air-intake port of engine and other openings like the muffler with a vinyl sheet, packing tape, etc., to prevent moisture and dust from getting in the unit.
- ⑥ Measure the insulation resistance of the generator, and make sure that it is more than $1M\Omega$. (See 5.5.4)
- ⑦ Be sure to repair any trouble and maintain the unit so that it will be ready for the next operation.

WARNING

- When stacking up the machines for storage, only two units stacking is acceptable. The mass of the lower machine should be larger than that of the upper one.
- Select a leveled floor with sufficient strength.
- Before stacking the machines up, check the machine for deformation of bonnet, looseness or missing of bolts, and other parts.
- When stacking them, be sure to securely fix them as shown in the figure so that the balanced weight is applied to each squared lumber for preventing a sideslip or a collapse.
- Never operate the machines with stacking conditions. It is very dangerous.
- Machines stacked could fall down due to sideslip or collapse when an earthquake occurs. Therefore, safety should be sufficiently considered for surroundings of storage places.

Stacking up box type machines

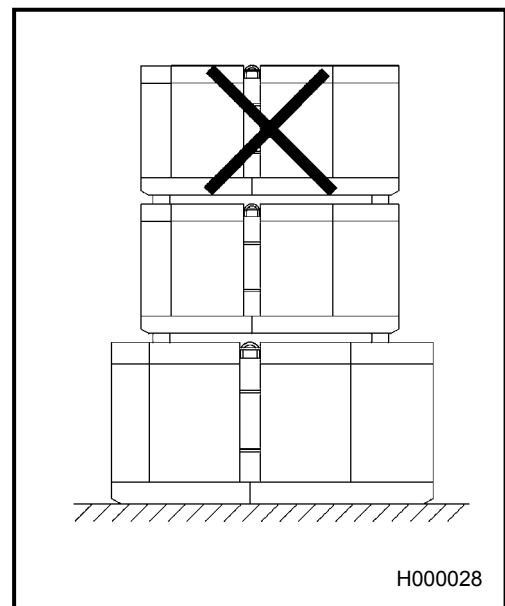

8. Specifications

8.1 Specifications

Model		SDG45S-8B1			
Generator	Exciting system		Brushless		
	Armature connection		Star with Neutral	ZigZag	
	Phase number		Three	Single	
	Power factor	%	80	100	
	Frequency	Hz	60		
	Rated output	kVA	45	26	
	Rated output	kW	36	26	
	Voltage	V	240	480	240/120
	Current	A	108	54	108
Engine	Model		ISUZU BU-4JJ1T		
	Type		4-cycle, water-cooled, direct injection, turbo charged		
	Number of cylinders		4		
	Total displacement	cu. in. (L)	183 (2,999)		
	Rated output	hp (kW)	57 (42.5)		
	Revolution per minute	rpm (min ⁻¹)	1,800 (1,800)		
	Lubricating oil capacity	gal. (L)	4.0 (15.0)		
	Coolant capacity (including radiator)	gal. (L)	2.7 (10.1)		
	Battery		95D31R (12V)		
	Fuel tank capacity	gal. (L)	106 (400)		
General Specifications	Overall length	in. (mm)	82 (2,080)		
	Overall width	in. (mm)	39 (1,000)		
	Overall height	in. (mm)	61 (1,560)		
	Net dry mass (weight)	lbs (kg)	2,735 (1,240)		
	Operating mass (weight)	lbs (kg)	3,530 (1,600)		
Others	The capacity of oil fence	gal. (L)	41 (155)		

8. Specifications

Model		SDG65S-8B1			
Generator	Exciting system		Brushless		
	Armature connection		Star with Neutral	ZigZag	
	Phase number		Three	Single	
	Power factor	%	80	100	
	Frequency	Hz	60		
	Rated output	kVA	63	36.5	
	Rated output	kW	50	36.5	
	Voltage	V	240	480	240/120
	Current	A	152	76	152
Engine	Model		ISUZU BJ-4JJ1X		
	Type		4-cycle, water-cooled, direct injection, turbo charged, intercooled		
	Number of cylinders		4		
	Total displacement	cu. in. (L)	183 (2,999)		
	Rated output	hp (kW)	81.8 (61.0)		
	Revolution per minute	rpm (min ⁻¹)	1,800 (1,800)		
	Lubricating oil capacity	gal. (L)	4.0 (15.0)		
	Coolant capacity (including radiator)	gal. (L)	2.9 (11.0)		
	Battery		95R31R (12V)		
	Fuel tank capacity	gal. (L)	106 (400)		
General Specifications	Overall length	in. (mm)	82 (2,080)		
	Overall width	in. (mm)	39 (1,000)		
	Overall height	in. (mm)	61 (1,560)		
	Net dry mass (weight)	lbs (kg)	2,875 (1,305)		
	Operating mass (weight)	lbs (kg)	3,660 (1,660)		
Others	The capacity of oil fence	gal. (L)	41 (155)		

8. Specifications

8.2 Outline drawing

SDG45S-8B1

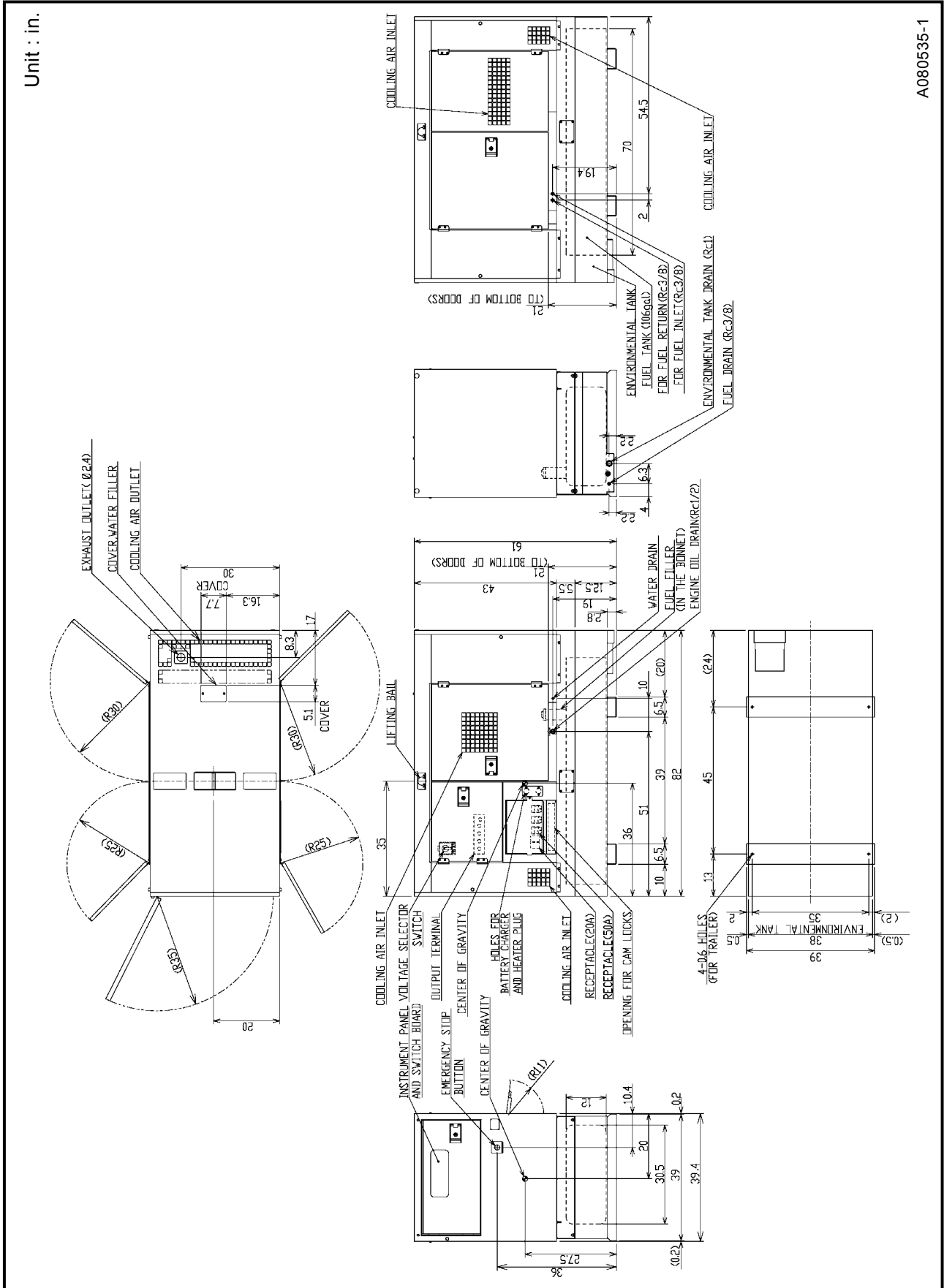

A080535-1

8. Specifications

SDG65S-8B1

Unit : in.

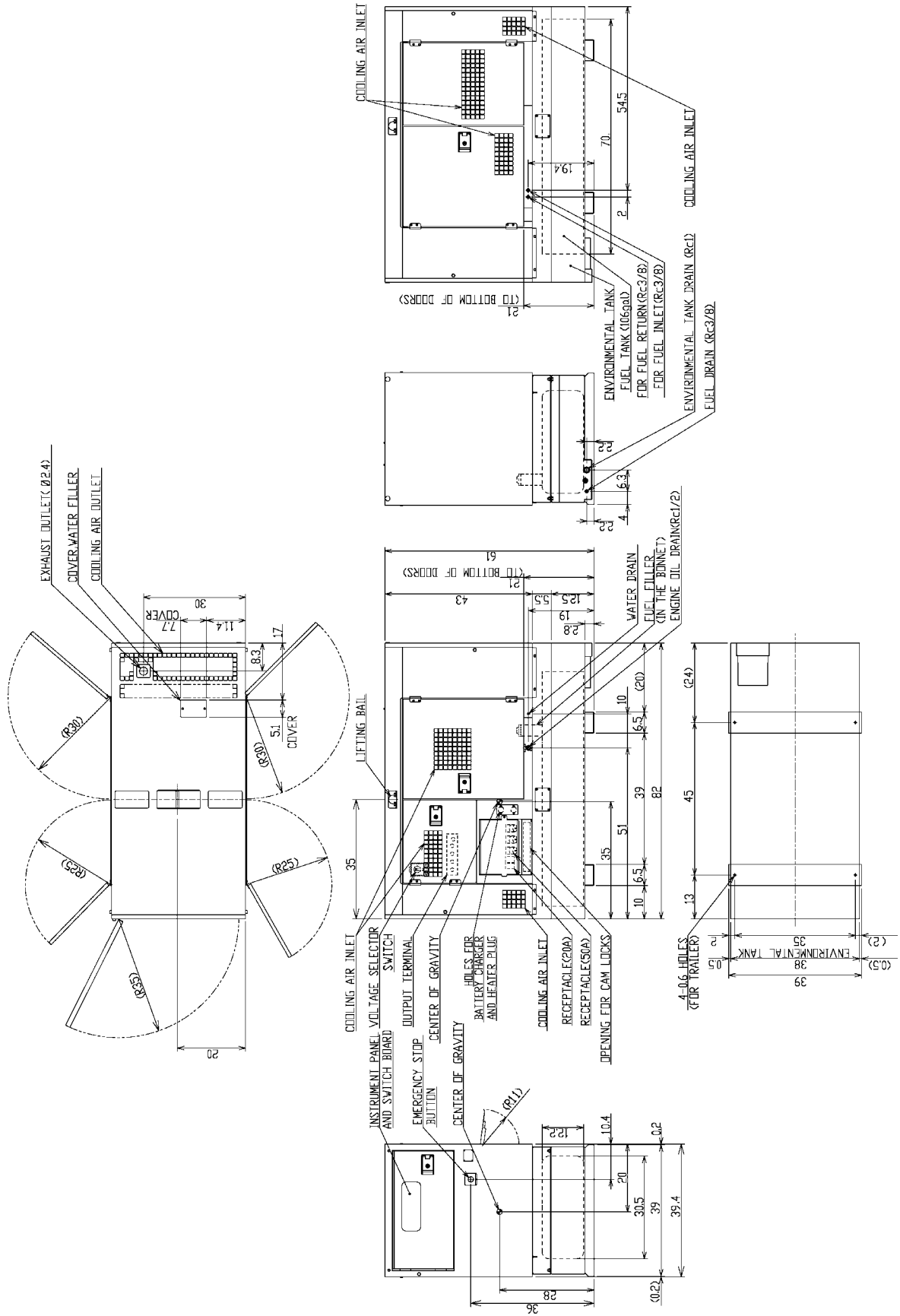

A080538-1

8. Specifications

Unit : mm

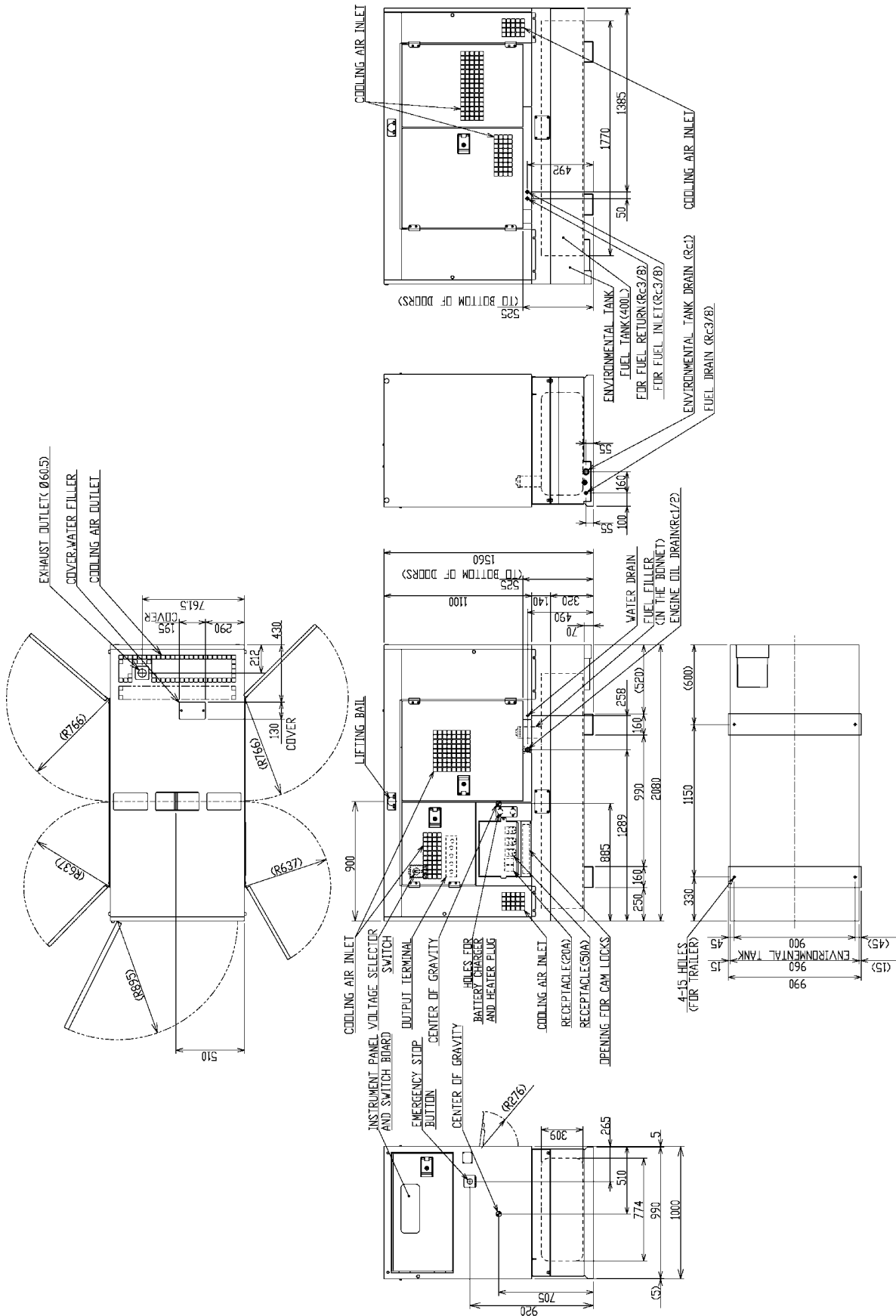

A080539

9. Wiring Diagram

9.1 Generator Wiring Diagram

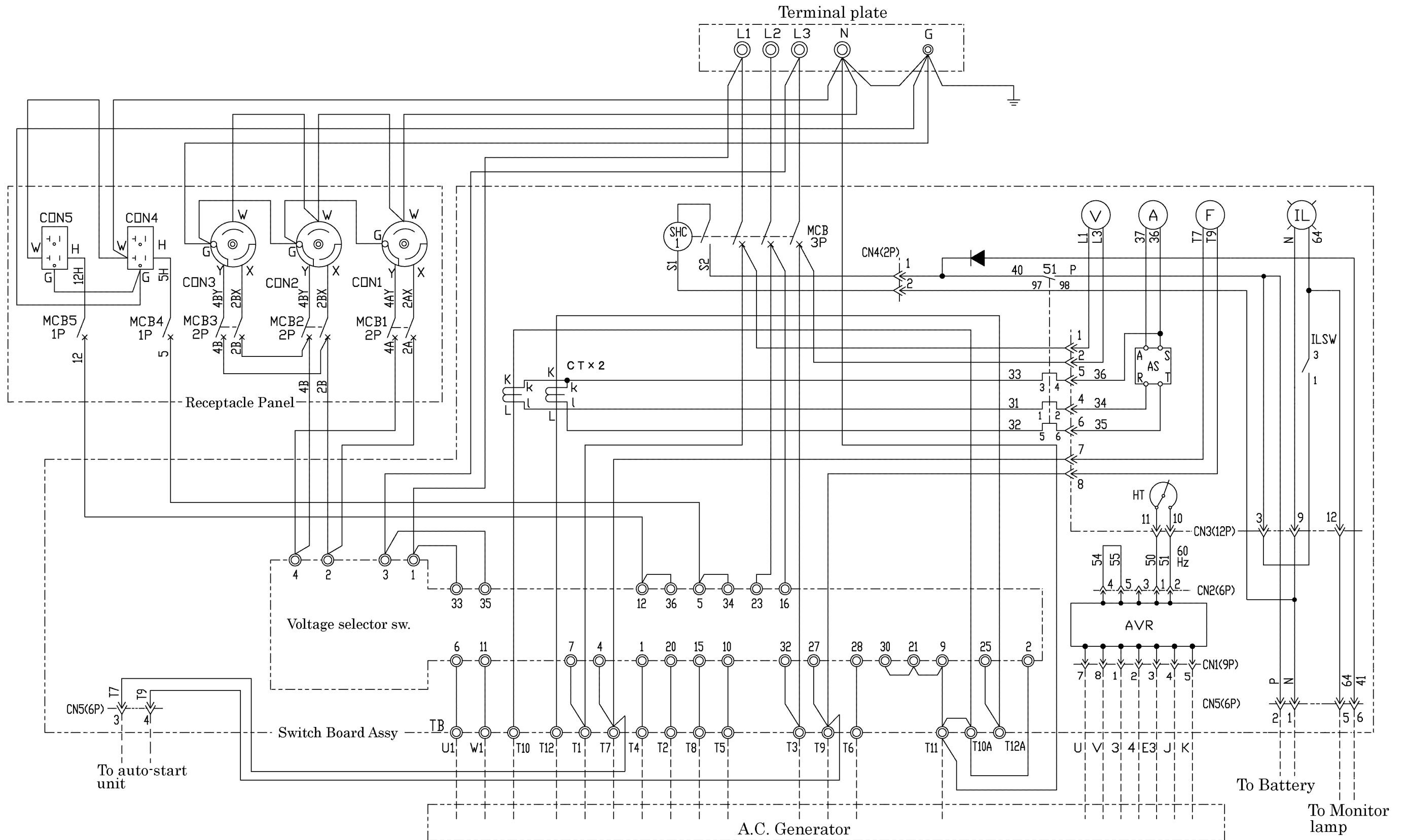

9. Wiring Diagram

9.2 Engine Wiring Diagram

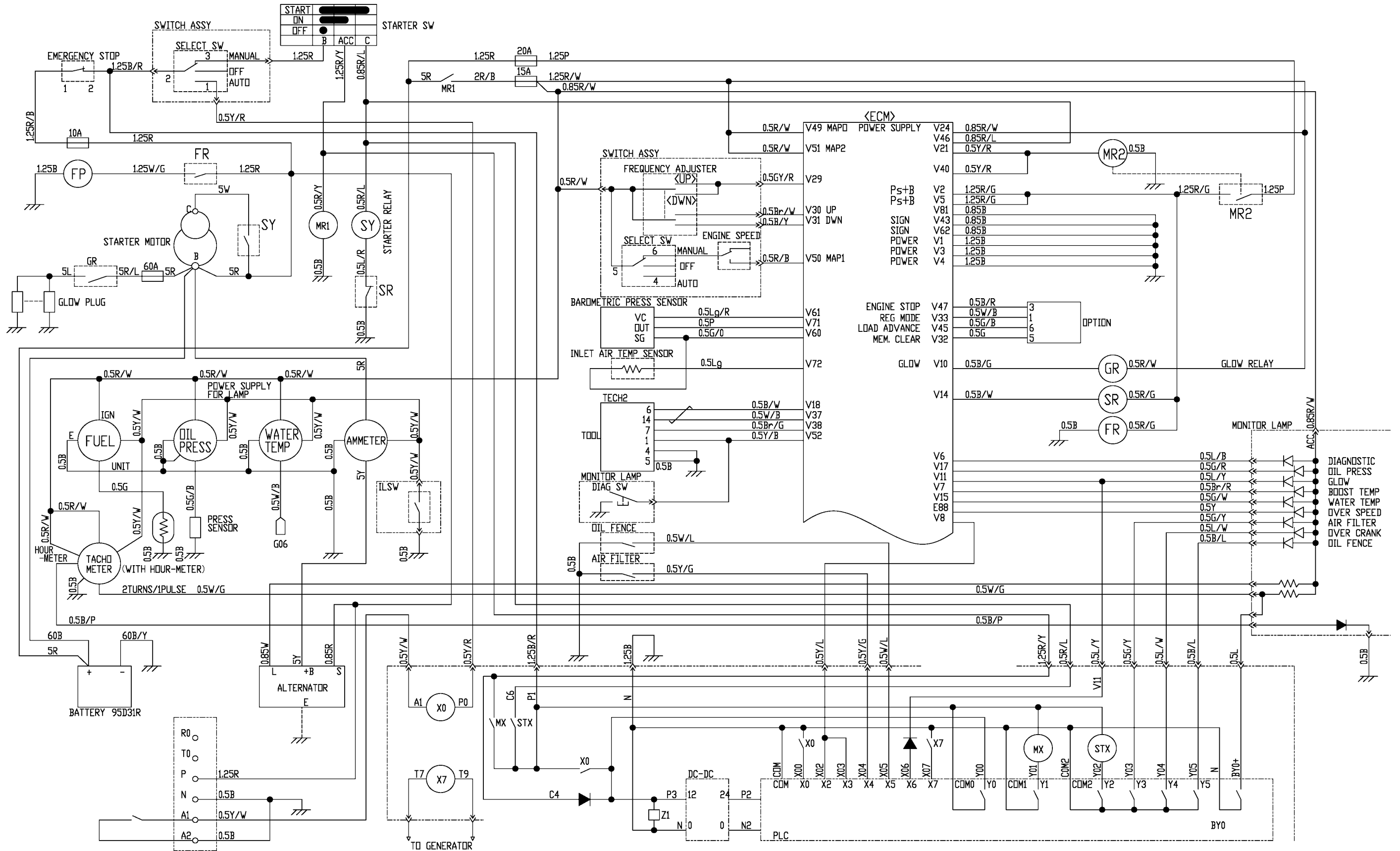

9. Wiring Diagram

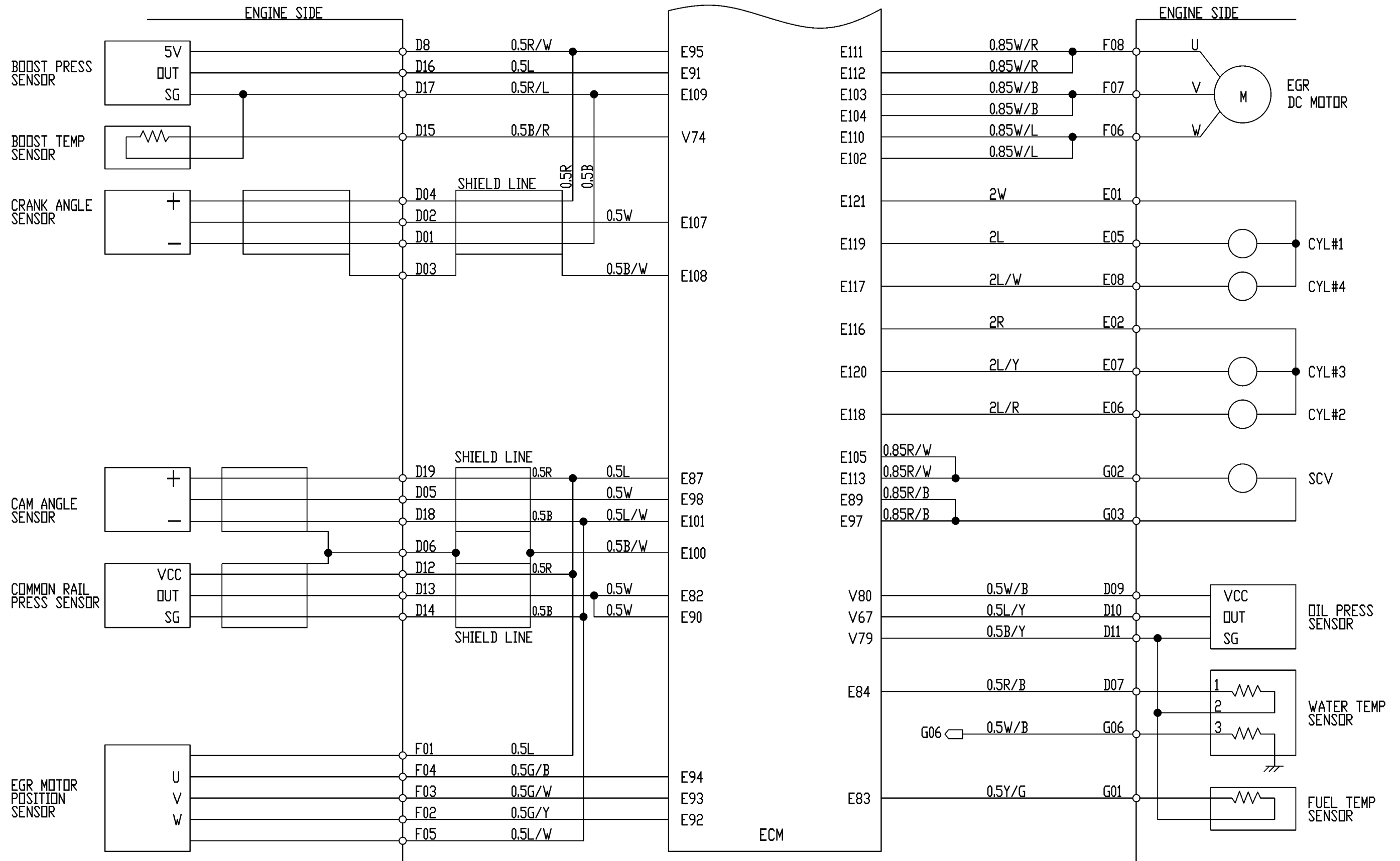

HOKUETSU INDUSTRIES CO., LTD.

8TH FLOOR SHINJUKU SAN-EI BLDG,
22-2 NISHI-SHINJUKU 1-CHOME, SHINJUKU-KU
TOKYO 160-0023 JAPAN
TEL:81-3-3348-7281
FAX:81-3-3348-7289
URL:<http://www.airman.co.jp>

Copyright(C)2009 HOKUETSU INDUSTRIES CO., LTD. All Rights Reserved

39600 96520
PRINTED IN JAPAN 2010. 2



AIRMAN
HOKUETSU INDUSTRIES CO., LTD.