



DCA125SSI

WhisperWatt™ Generator

WhisperWatt™ 125

Prime Rating: 100 kW (125 kVA)

Standby Rating: 110 kW (137 kVA)

60 Hertz

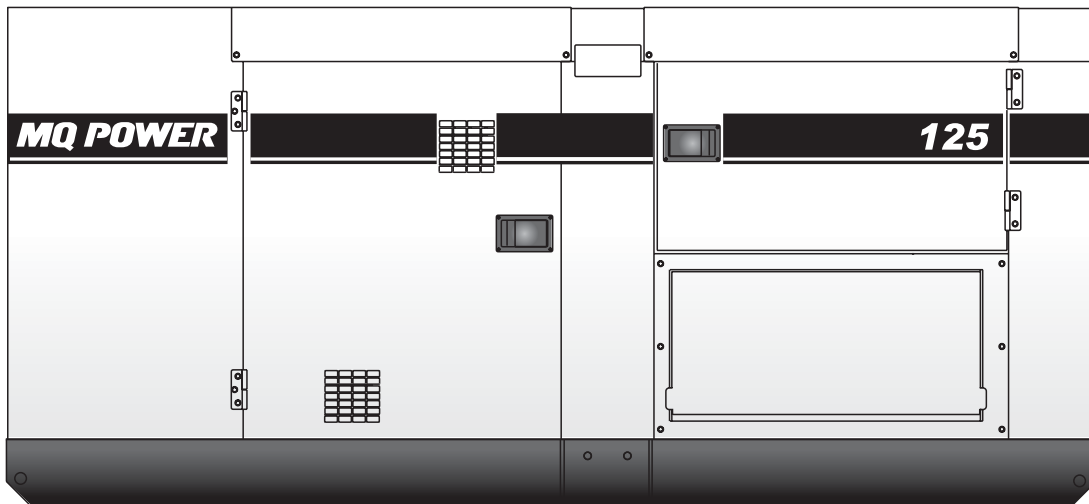

Standard Features

- **Heavy duty, 4-cycle, direct injection, turbocharged, air to air intercooled diesel engine** provides maximum reliability.
- **Brushless alternator** reduces service and maintenance requirements and meets temperature rise standards for Class F insulation systems.
- **Open delta alternator design** provides virtually unlimited excitation for maximum motor starting capability.
- **Automatic voltage regulator (AVR)** provides precise regulation.
- **Electronic governor system** maintains frequency to $\pm 0.25\%$.
- **Full load acceptance** of standby nameplate rating in one step (NFPA 110, para 5-13.2.6).
- **Sound attenuated, weather resistant, steel housing** provides operation at 68 dB(A) at 23 feet. Fully lockable enclosure allows safe unattended operation.
- **Internal fuel tank** with direct reading fuel gauges are standard.
- **Seven stage powder coat paint** provides durability and weather protection.
- **Complete engine analog instrumentation** includes DC ammeter, oil pressure gauge, water temp. gauge, fuel level gauge, tachometer/hour meter, manual engine speed control, and emergency shutdown monitors.
- **Complete generator analog instrumentation** includes voltage regulator control, ammeter phase selector switch, voltmeter phase selector switch, AC voltmeter, AC ammeter, frequency meter, panel light, and circuit breaker.
- **Automatic safety shutdown system** monitors the water temperature, engine oil pressure, overspeed, and overcrank. Warning lights indicate abnormal conditions.
- **Auto start/stop control** allows generator to start automatically in the event of a commercial power failure.
- **Complete power panel.** Fully covered; three-phase terminals and single phase receptacles allow fast and convenient hookup for most applications including temporary power boxes, tools and lighting equipment. All are NEMA standard.
- **Fuel/water separator** removes condensation from fuel for extended engine life.
- **EPA emissions certified** - Tier 3 emissions compliant.



DCA125SSI

WhisperWatt™ Generator

Specifications

Generator Specifications	
Design	Revolving field, Self-ventilated Drip-proof, Single bearing
No. of Poles	4-pole
Excitation	Brushless with AVR
Standby Output	110 KW (137 KVA)
Prime Output	100 KW (125 KVA)
Generator RPM	1800
Voltage — 3Ø	208, 220, 240, 416, 440, 480V Switchable
Voltage — 1Ø	120, 127, 139, 240, 254, 277V Switchable
Armature Connection	Star with neutral / Zig Zag
Voltage Regulation (No load to full load)	±0.5%
Power Factor	0.8
Frequency	60 Hz
Frequency Regulation: No Load to Full Load	Isochronous under varying loads from no load to 100% rated load
Frequency Regulation: Steady State	±0.25% of mean value for constant loads from no load to full load
Insulation	Class F
Sound Level dB(A) Full load at 23 feet	68

Engine Specifications	
Make/Model	Isuzu / 4HK1X
Emissions	EPA Tier 3 Certified
Starting System	Electric
Design	4-cycle, watercooled, direct injection, turbocharged, air to air intercooled
Displacement	5193 cc
No. cylinders	4
Bore x Stroke (mm)	115 x 125
Gross Engine Power Output	170.3 hp (127 kW)
HP at Rated Speed	152.3 hp (113.6 kW)
BMEP	212 psi (1458 kPa)
Piston Speed	1480 ft/min (7.50 m/s)
Compression Ratio	17.5 : 1
Engine Speed	1800 rpm
Overspeed Limit	2070 rpm
Oil capacity gallons (liters)	6.1 (23.0)
Battery	12V 128 Ah x 1

Fuel System	
Recommended Fuel	ASTM-D975-No.1 and No. 2-D
Maximum Fuel Flow (per hour)	19.0 gal (71.0 L)
Maximum Inlet Restriction (Hg)	8.9 in (225 mm)
Fuel Tank Capacity	69 gal (260 L)
Fuel Consumption	
full load gph (lph)	7.3 (27.6)
75% load gph (lph)	5.7 (21.7)
50% load gph (lph)	4.1 (15.4)
25% load gph (lph)	2.5 (9.5)

Cooling System	
Fan Load	4.0 hp (3.0kW)
Coolant Capacity (with radiator)	5.3 gal (20.2 L)
Coolant Flow Rate (per minute)	48 gal (180 L)
Heat Rejection to Coolant (per minute)	3500 Btu (3.7 MJ)
Heat Rejection from Engine (per minute)	1040 Btu (1.1 MJ)
Maximum Coolant Friction Head	6.5 psi (45.0 kPa)
Maximum Coolant Static Head	29.5 ft (9.0 m)
Ambient Temperature Rating	104°F (40°C)

Air	
Combustion Air	297 cfm (8.4 m³/min)
Maximum Air Cleaner Restriction	25.0 in H ₂ O (6.25 kPa)
Alternator Cooling Air	1352 cfm (38.3 m³/min)
Radiator Cooling Air	4590 cfm (130 m³/min)

Exhaust System	
Gas Flow (full load)	738 cfm (20.9 m³/min)
Gas Temperature	986°F (530°C)
Maximum Back Pressure	53.2 in/H ₂ O (13.3 kPa)

Amperage	
Rated Voltage	Maximum Amps
1Ø 120 Volt	277.8 Amps (4 wire)
1Ø 240 Volt	138.9 Amps (4 wire)
3Ø 240 Volt	300 Amps
3Ø 480 Volt	150 Amps
Main Line Circuit Breaker Rating	300 Amps
Over Current Relay Trip Set Point	152 Amps

Warranty*

Isuzu Engine

12 months from date of purchase with unlimited hours or 24 months from date of purchase with 2000 hours (whichever comes first).

Generator

24 months from date of purchase or 2000 hours (whichever occurs first).

Trailer

12 months excluding normal wear items.

*Refer to the express written, one-year limited warranty sheet for additional information.

Generator is not intended for use in enclosed areas or where free flow of air is restricted. Backfeed to a utility system can cause electrocution and/or property damage. Do not connect to any building's electrical system except through an approved device.

Specifications are subject to change without notice.



DCA125SSI

WhisperWatt™ Generator

MQ POWER DECIBEL LEVELS

Our soundproof housing allows substantially lower operating noise levels than competitive designs. WhisperWatts are at home on construction sites, in residential neighborhoods, and at hospitals — just about anywhere.

- 90 — Subway / truck traffic
- 80 — Average city traffic
- 70 — Inside car at 60 mph
— WhisperWatt at 23 feet
- 60 — Air conditioner at 20 feet
- 50 — Normal conversation



Generator Output Panel

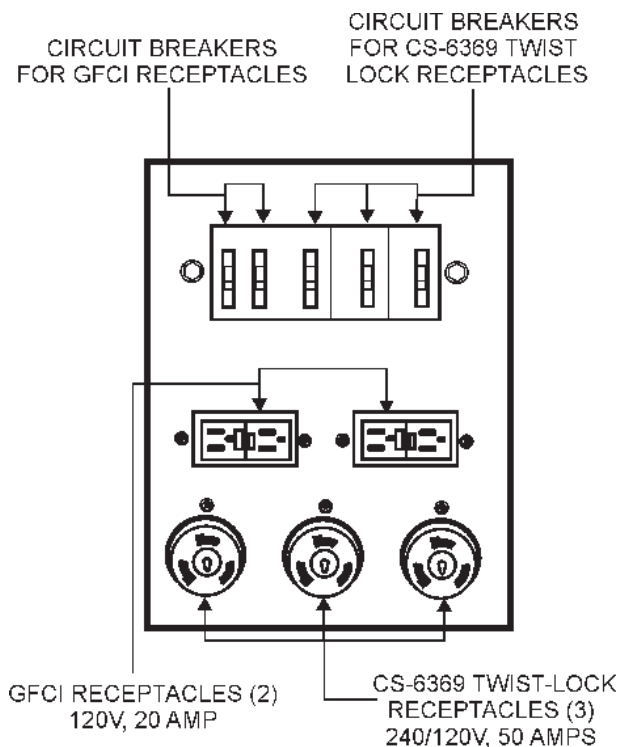

Optional Generator Features

- Battery charger** — provides fully automatic and self-adjusting charging to the generator's battery system.
- Jacket water heater** — for easy starting in cold weather climates.
- Special batteries** — long life batteries provide extra engine cranking power.
- Spring isolators** — provides extra vibration protection for standby applications.
- Trailer mounted package** — highway legal, double axle trailer with electronic or surge brakes. Extra capacity fuel tanks are also available.

Optional Control Features

- Audible alarm** alerts operator of abnormal conditions.
- Low coolant level shutdown system** provides protection from critically low coolant levels. Includes control panel warning light.
- Emergency stop switch**

Optional Fuel Cell Features

- Trailer fuel tank** — a second fuel cell located in the trailer allows for extended run time.
- Sub-base fuel cells (double wall)** — Additional fuel cell for extended runtime operation. Contains a leak sensor, low fuel level switch, and a secondary containment tank. UL142 listed.
 - 12 hours of minimum run time.
 - 24 hours of minimum run time.

Optional Output Connections

- Cam-Loks** — provides quick disconnect alternative to bolt-on connectors.
- Pin and Sleeve Connectors** — provides industry standard connectors for all voltage requirements.
- Output Cable** — available in any custom length and size configuration.



DCA125SSI

WhisperWatt™ Generator

Dimensions

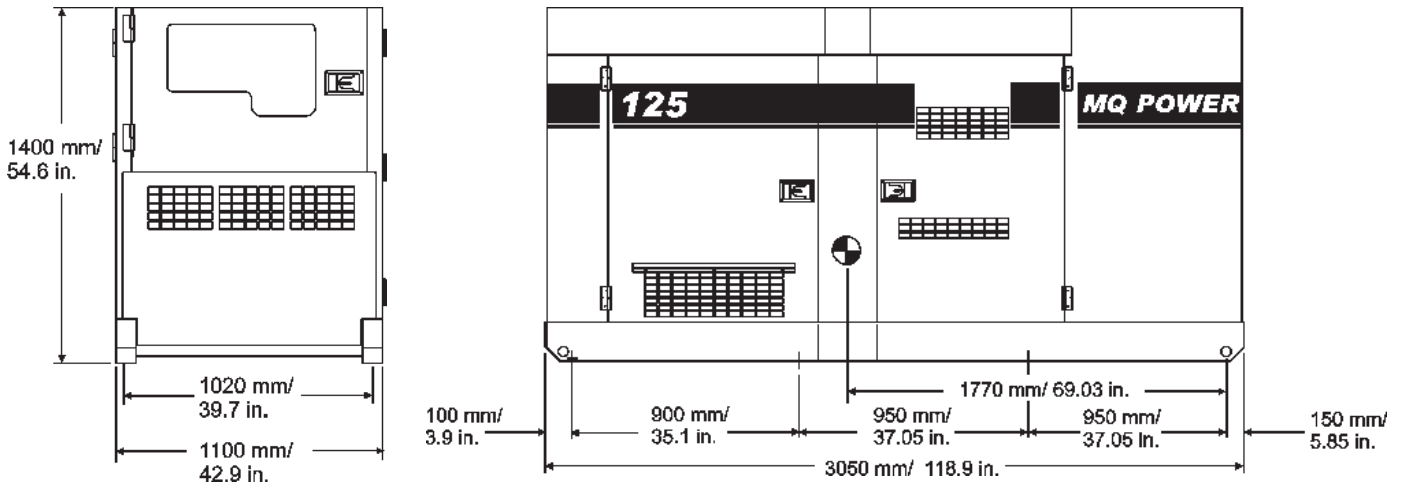

Weight

Dry Weight	4609 lb (2090 kg)
Wet Weight	5182 lb (2350 kg)

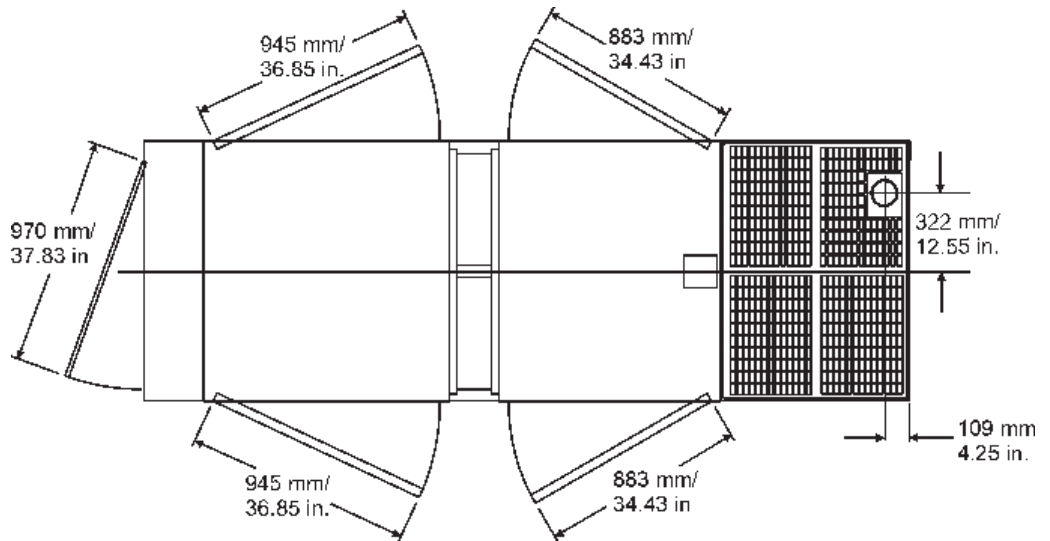

Manufactured by Denyo Co.

Your MQ Power dealer is:



MQ POWER
 POST OFFICE BOX 6254
 CARSON, CA 90749
 310-537-3700 • 800-883-2551
 FAX: 310-604-3831
 E-MAIL: mqpower@multiquip.com
 WEBSITE: www.mqpower.com