



Available in cage, on wheels or skid



We know how water works

2 Inch  
Diaphragm Pumps  
Gas Powered

Backed By CH&E  
Limited Warranty

### MODELS AND SPECIFICATIONS

MODEL (Aluminum/Cast Iron)	5437/6437	5438/6438	5435/6435
Suction & Discharge	2 inch	2 inch	2 inch
Max. Suction Lift (feet)	25	25	25
Max. Discharge Head (feet)	25	25	25
Power	Honda GX120	Honda GX140	B&S 128432
Max. Horsepower/RPM	4.0/3600	5.5/3600	5.5/3600
Fuel Tank Capacity (US Gal.)	0.66	0.95	1.00
Continuous Run Time/Tank (Hr.)	3	3.3	3
Starting Method	Recoil	Recoil	Recoil
Shipping Dimensions (L x W x H in.)			
Wheels	40 x 25 x 23	40 x 25 x 23	40 x 25 x 23
Skid	39 x 25 x 28	39 x 25 x 28	39 x 25 x 28
Cage	35 x 23 x 26	35 x 23 x 26	35 x 23 x 26
Shipping Weight (lb.)			
Aluminum Net Wt./Shipping Wt.	126/141	131/146	102/117
Cast Iron	154/169	159/174	130/145

**WARNING**  
DO NOT USE IN EXPLOSIVE  
ATMOSPHERE OR FOR PUMPING  
VOLATILE FLAMMABLE LIQUIDS



A Division of ABS Pumps

3849 N. Palmer St., Milwaukee, WI 53212 • Phone 414-964-3400 • FAX 414-964-0677  
E-mail: [dewatering@absgroup.com](mailto:dewatering@absgroup.com)



We know how water works

# 2 Inch Diaphragm Pumps Gas Powered

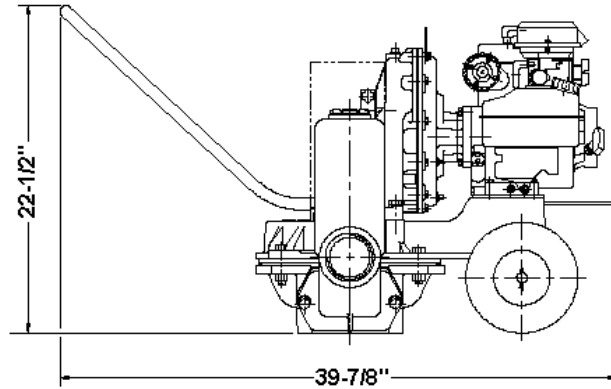
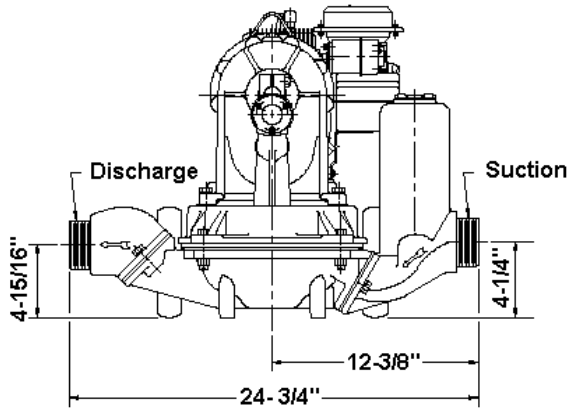

### BUILT TO LAST

- Aluminum or Cast Iron wetted ends
- Large opening Flap Valves
- Fast, Sure Self Priming(Dry Primes to 20 ft. Suction Lift)
- Self Cleaning Water Flow
- Enclosed Gears in Oil Bath
- Diaphragm and Valves in Rubber, TPE, Neoprene, Buna and Viton

### MORE PRODUCTIVE PUMPING FOR:

- Seepage Dewatering
- Sandy- Muddy- Mucky- Water
- High Suction Lift
- Cleaning Septic Tanks
- Pumping Industrial Waste
- Pumping Marine Tanks

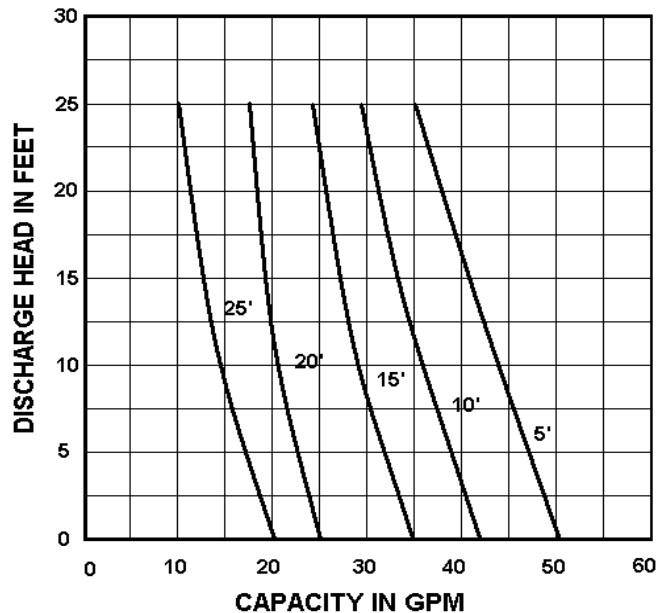

A Division of ABS Pumps

3849 N. Palmer St., Milwaukee, WI 53212 • Phone 414-964-3400 • FAX 414-964-0677  
E-mail: [dewatering@absgroup.com](mailto:dewatering@absgroup.com)